

THERMOCOUPLE TRANSMITTER
 (PC programmable)

MODEL

M2EXT**CONTENTS**

BEFORE USE	2
POINTS OF CAUTION.....	2
COMPONENT IDENTIFICATION	2
INSTALLATION	3
TERMINAL CONNECTIONS	3
EXTERNAL VIEWS	4
DIP SWITCH	4
SCREEN DISPLAY.....	5
PROGRAMMING	6
ERROR MESSAGES.....	16
WIRING INSTRUCTIONS.....	16
CHECKING	16
MAINTENANCE.....	17
LIGHTNING SURGE PROTECTION	17

BEFORE USE

Thank you for choosing us. Before use, please check contents of the package you received as outlined below.

If you have any problems or questions with the product, please contact our sales office or representatives.

■ PACKAGE INCLUDES:

Signal conditioner (body + base socket + CJC sensor).....(1)

■ MODEL NO.

Confirm Model No. marking on the product to be exactly what you ordered.

■ OPERATING MANUAL

This manual describes detailed operation regarding settings.

The M2EXT is programmable using a PC. For detailed information on the PC configuration, refer to the M2EFCFG users manual (EM-5147).

The M2EFCFG Configurator Software is downloadable at our web site.

POINTS OF CAUTION

■ CONFORMITY WITH EU DIRECTIVES

- This equipment is suitable for Pollution Degree 2 and Installation Category II (transient voltage 2500V). Reinforced insulation (signal input or output to power input: 300V) and basic insulation (signal input to output: 300V) are maintained. Prior to installation, check that the insulation class of this unit satisfies the system requirements.
- Altitude up to 2000 meters.
- The equipment must be mounted inside a panel.
- The equipment must be installed such that appropriate clearance and creepage distances are maintained to conform to CE requirements. Failure to observe these requirements may invalidate the CE conformance.
- The actual installation environments such as panel configurations, connected devices, connected wires, may affect the protection level of this unit when it is integrated in a panel system. The user may have to review the CE requirements in regard to the whole system and employ additional protective measures* to ensure the CE conformity.
 - * For example, installation of noise filters and clamp filters for the power source, input and output connected to the unit, etc.
- Install lightning surge protectors for those wires connected to remote locations.

■ POWER INPUT RATING & OPERATIONAL RANGE

- Locate the power input rating marked on the product and confirm its operational range as indicated below:

100 – 240V AC rating: 85 – 264V, 47 – 66 Hz,
 ≤ 4.5VA at 100V AC
 ≤ 6.5VA at 200V AC
 ≤ 8.5VA at 264V AC

24V DC rating: 24V ±10%, ≤ 2.3W

110V DC rating: 85 – 150V, ≤ 2.3W

■ GENERAL PRECAUTIONS

- Before you remove the unit from its base socket or mount it, turn off the power supply and input signal for safety.

■ ENVIRONMENT

- Indoor use.
- When heavy dust or metal particles are present in the air, install the unit inside proper housing with sufficient ventilation.
- Do not install the unit where it is subjected to continuous vibration. Do not subject the unit to physical impact.
- Environmental temperature must be within -5 to +55°C (23 to 131°F) with relative humidity within 10 to 85% RH in order to ensure adequate life span and operation.
- Be sure that the ventilation slits are not covered with cables, etc.

■ WIRING

- Do not install cables close to noise sources (relay drive cable, high frequency line, etc.).
- Do not bind these cables together with those in which noises are present. Do not install them in the same duct.

■ AND

- The unit is designed to function as soon as power is supplied, however, a warm up for 10 minutes is required for satisfying complete performance described in the data sheet.
- With voltage output, do not leave the output terminals shortcircuited for a long time. The unit is designed to endure it without breakdown, however, it may shorten appropriate life duration.
- The edge of the display may be hidden by the frame and invisible depending on the view angle.

COMPONENT IDENTIFICATION

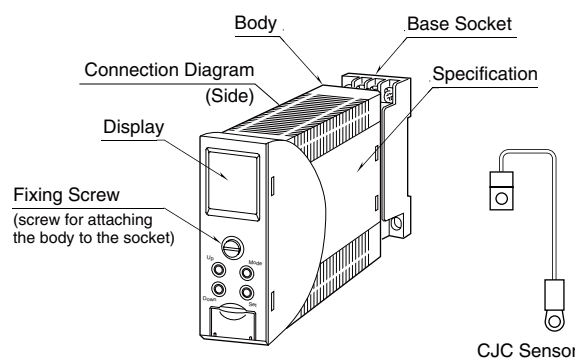

INSTALLATION

Loosen the fixing screw in front of the unit in order to separate the body from the base socket.

FIXING SCREW

The fixing screw can be pushed into the body when it is not in use. Tighten the knob until the body is securely attached to the base socket. Push it into the body and turn it clockwise to lock. Push the knob and turn it counterclockwise to unlock so that the knob pops out.

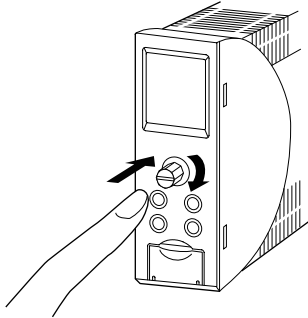

DIN RAIL MOUNTING

Set the base socket so that its DIN rail adaptor is at the bottom. Position the upper hook at the rear side of base socket on the DIN rail and push in the lower. When removing the socket, push down the DIN rail adaptor utilizing a minus screwdriver and pull.

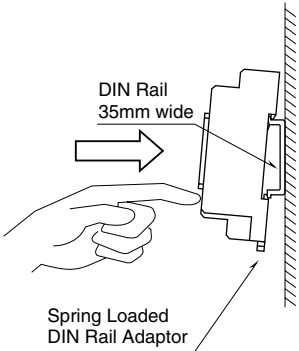

WALL MOUNTING

Refer to "EXTERNAL DIMENSIONS."

TERMINAL CONNECTIONS

Connect the unit as in the diagram below or refer to the connection diagram on the side of the unit.

EXTERNAL DIMENSIONS unit: mm (inch)

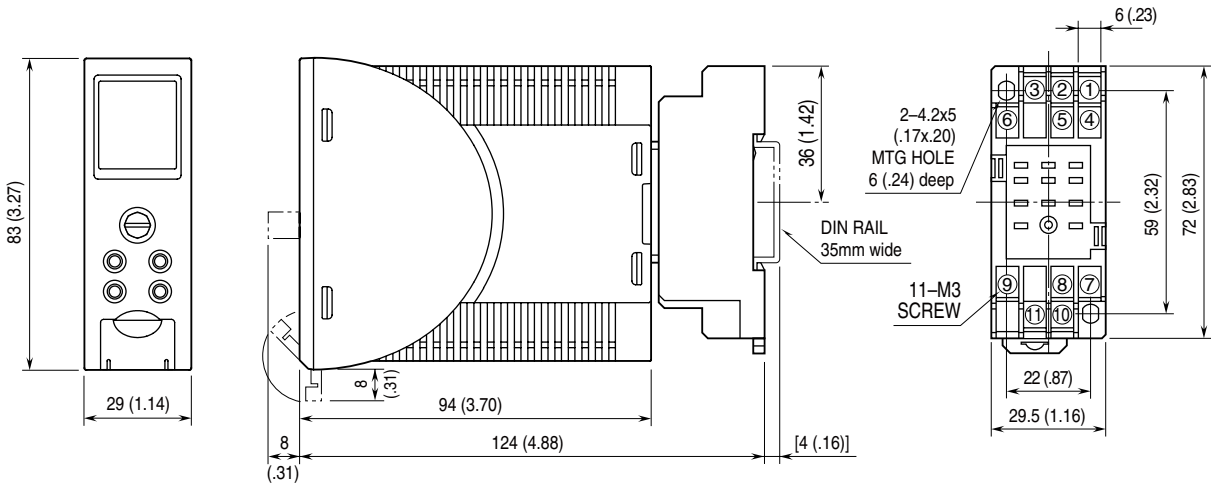

• When mounting, no extra space is needed between units.

CONNECTION DIAGRAM

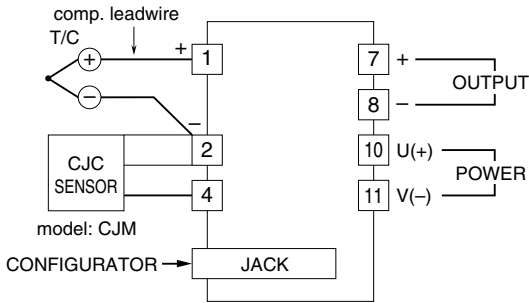

TERMINAL ASSIGNMENTS

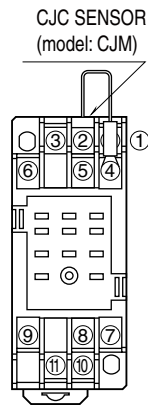

EXTERNAL VIEWS

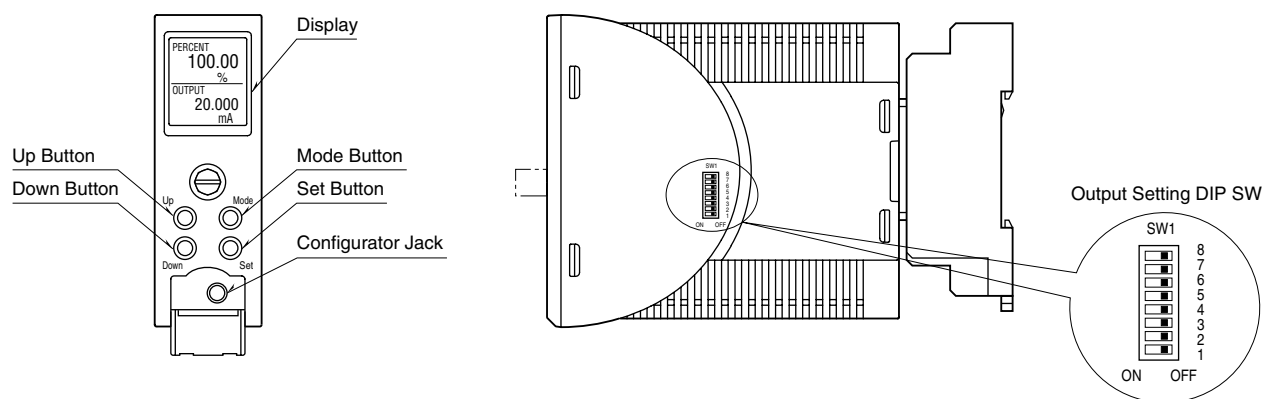

COMPONENT	FUNCTION
Display	Indicates present values, setting values and abnormal information. Two types of present values are displayed respectively at the upper and lower parts according to setting.
Mode Button	Shifts from Measuring mode to each setting mode. The destination changes depending on how long the button is held down. Pressing Mode button for ≥ 2 seconds returns to Measuring mode from each setting mode..
Set Button	Shifts the setting value of each setting parameter item to a setting changeable state. When at setting changeable state, used to move through the digits of setting value for input/output scaling and to enter (save) the setting value.
Up Button	Shifts through setting parameter items and to increase or select the setting value.
Down Button	Shifts through setting parameter items and to decrease or select the setting value.
Configurator Jack	Used to perform configuration with M2E configurator software (model: M2ECFG). When using the software, set the Lockout setting of the unit to 'Lock'.

DIP SWITCH

The internal DIP switch for output setting is required to select output types before setting a precise output range using front buttons or setting with a PC.

Refer to the "PROGRAMMING" for the operation with front buttons. Refer to the users manual (EM-5147) of M2E Configurator Software (model: M2ECFG) for setting with PC.

Output Range	SW1							
	1	2	3	4	5	6	7	8
0 – 20 mA	OFF	ON	OFF	OFF	OFF	OFF	ON	OFF
-5 – +5 V	OFF	OFF	ON	OFF	ON	OFF	OFF	ON
-10 – +10 V	OFF	OFF	ON	OFF	OFF	ON	OFF	ON

! CAUTION: DO NOT set DIP switches while power is supplied. Otherwise, the unit may fail.

SCREEN DISPLAY

■ DISPLAY IN MEASURING MODE

• Double tiered display

The unit can display any two items selected out of input engineering value, input electromotive force value, % value*, output engineering value, and output scaling value.

* Percent value for input.

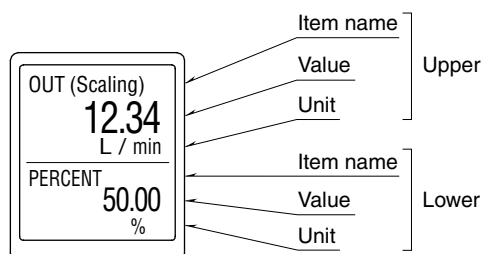

• Single tiered display

When there is only one item selected, the value can be displayed in large characters.

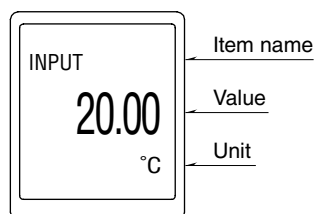

Refer to the settings of Advanced mode for details.

■ DISPLAY IN EACH SETTING MODE

In each setting mode, setting parameter item name, item No., and setting value are indicated.

During setting, '(Setting)' is indicated next to 'DATA'.

If the power is mistakenly shut down during setting, the set value is discarded and returns to the value before setting change.

Setting display previously displayed before power shut-down is indicated at next power up.

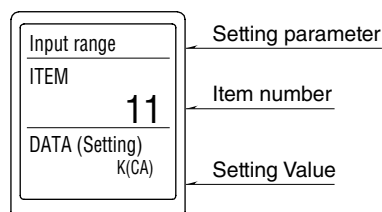

The long parameter item name is scrolled and displayed.

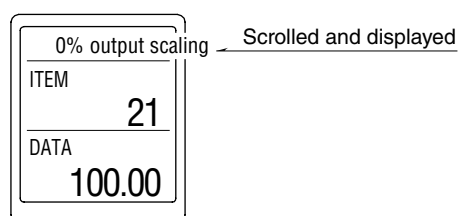

■ DISPLAY TIMEOUT

When there is no operation within the preset display timeout period, the display is cleared (display off).

Pressing Mode, Set, Up, or Down button or occurrence of an error restores the display from display off.

Set to '0' to keep the display 'always on'.

PROGRAMMING

■ SETTING FLOWCHART

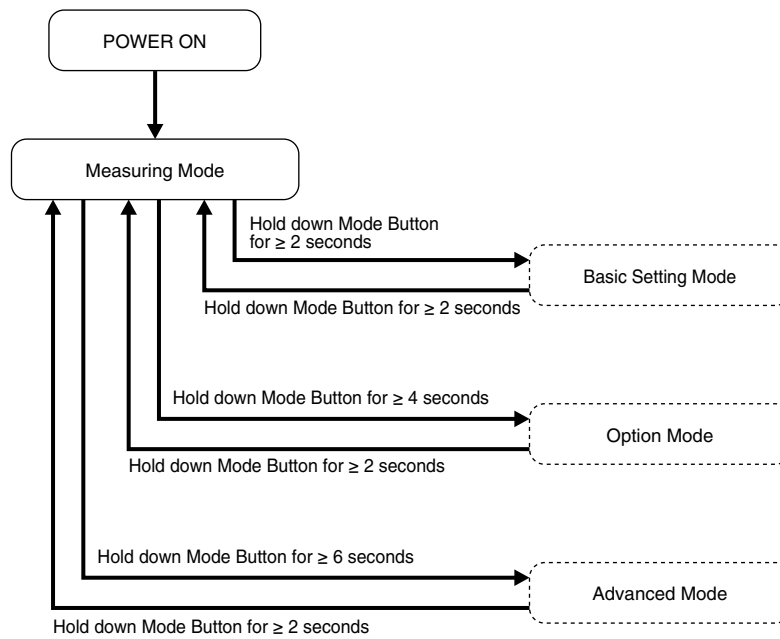

■ OPERATION IN EACH SETTING MODE

• Basic operation

Mode Button:	In measuring mode, holding down Mode button for ≥ 2 seconds, ≥ 4 seconds or ≥ 6 seconds enables to move on to each setting mode. Holding down Mode button for ≥ 2 seconds at each setting item display enables to return to measuring mode. Holding down Mode button for ≥ 2 seconds while changing settings ('(Setting)' is displayed next to 'DATA') enables to discard setting value in changing, and to return to the state before change settings ('(Setting)' next to 'DATA' is off).
Set Button:	Pressing Set button at each setting parameter enables to blink setting value and changing settings is ready ('(Setting)' is displayed next to 'DATA'). Pressing Set button while changing settings enables to save (enter) setting value and change from blinking to on.
Up Button:	Press Up button to move through setting parameters. Selecting setting value while changing settings, increasing a setting value to set value. Keeping pressing Up button enables to increase the value continuously.
Down Button:	Press Down button to move through setting parameters. Selecting setting value while changing settings, decreasing a setting value to set value. Keeping pressing Down button enables to decrease the value continuously.

Note: DO NOT press 2 or more buttons simultaneously.

• Output display scaling setting parameter

For output display scaling setting parameter, set values digit by digit. Pressing Set button enables to move blinking digit. Adjust blinking digit to set numerical value with Up and Down button. Blinking digit moves from most significant digit with pressing Set button. At least significant digit, pressing Set button again enables to turn on and determine the setting value. During setting, press and hold Mode button for ≥ 2 seconds to discard the setting value.

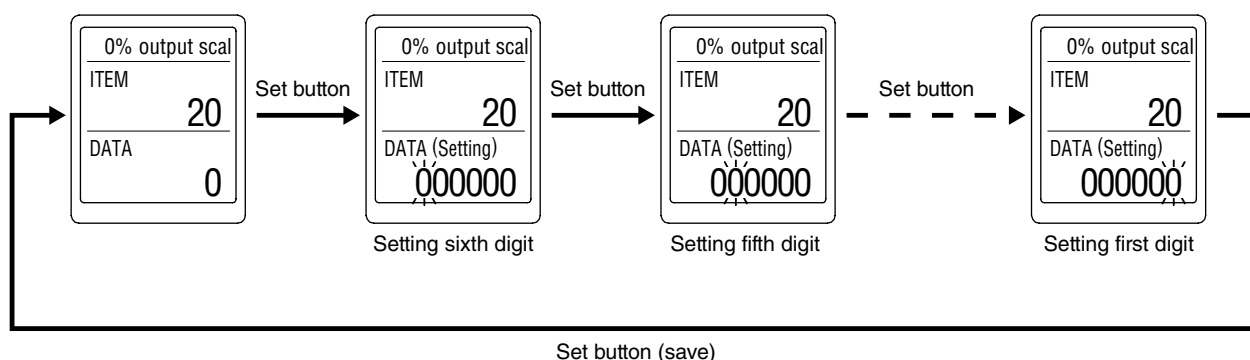

• Lockout setting

'Lockout setting' is available for the unit. When unlocking the lockout setting, indicate 'Lockout Setting' of 'ITEM 01' in each setting mode and set 'Unlock'. To enable lockout setting again, set 'Lock'. Even when lockout setting is enabled, it is available to confirm the each setting value. 'DATA (Locked)' is indicated in that case.

■ BASIC SETTING MODE

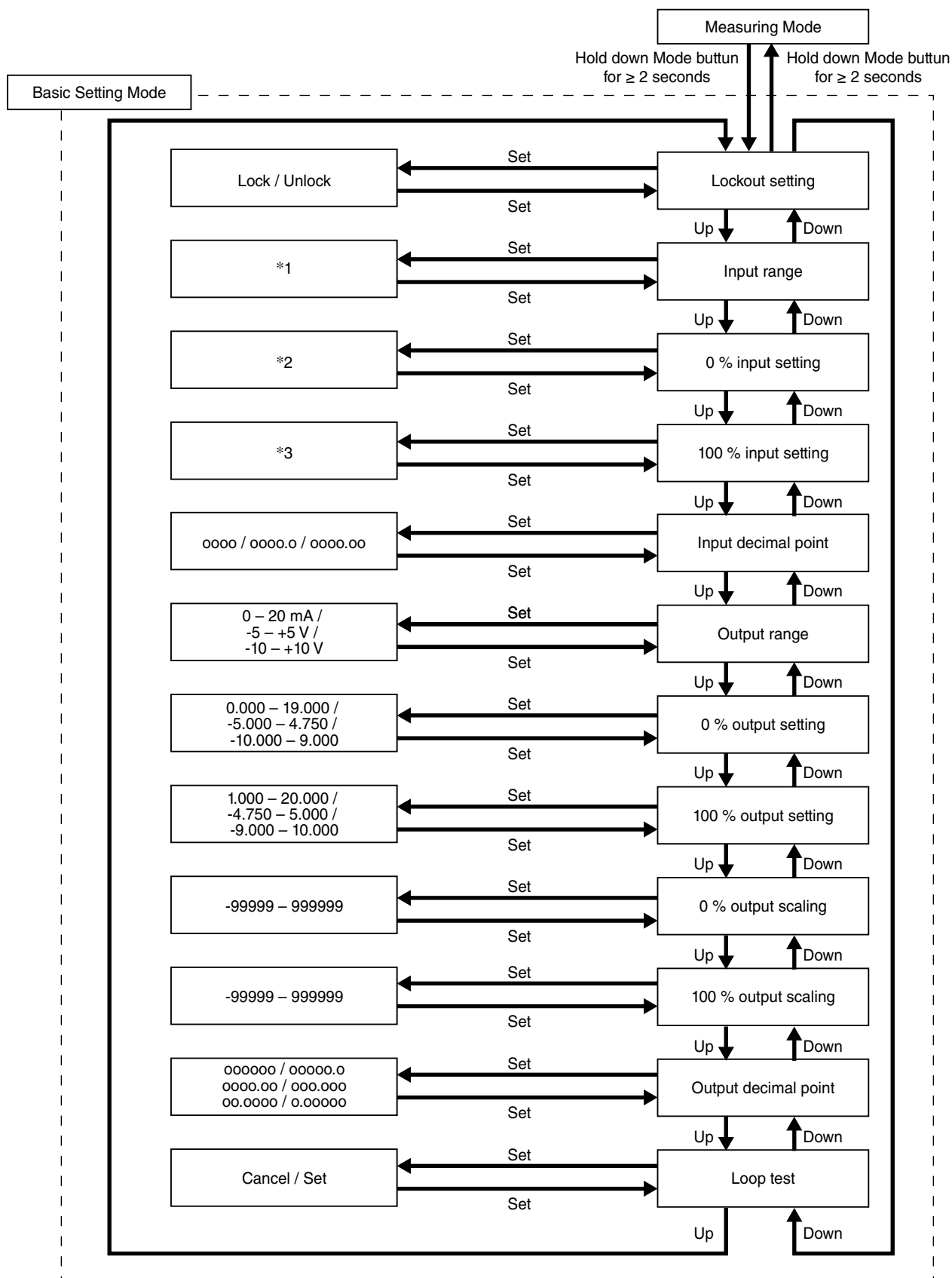

*1. Regarding available input range, refer to [11] Input range.

*2. Available range differs according to input type. Refer to [12] 0 % input setting.

*3. Available range differs according to input type. Refer to [13] 100 % input setting.

• Parameters

MODE	ITEM	SETTING PARAMETER	RANGE	UNIT	INITIAL VALUE
Basic setting	01	Lockout setting	Lock / Unlock	—	Lock
	11	Input range	(PR) K (CA) E (CRC) J (IC) T (CC) B (RH) R S C (WRe 5-26) N U L P (Platinel II)	—	K (CA)
	12	0 % input setting	(PR): 0.0 – 1740.0 K (CA): -270.0 – 1350.0 E (CRC): -270.0 – 980.0 J (IC): -210.0 – 1180.0 T (CC): -270.0 – 380.0 B (RH): 0.0 – 1800.0 R: -50.0 – 1740.0 S: -50.0 – 1740.0 C (WRe 5-26): 0.0 – 2295.0 N: -270.0 – 1280.0 U: -200.0 – 580.0 L: -200.0 – 880.0 P (Platinel II): 0.0 – 1375.0	°C	0.0
	13	100 % input setting	(PR): 20.0 – 1760.0 K (CA): -250.0 – 1370.0 E (CRC): -250.0 – 1000.0 J (IC): -190.0 – 1200.0 T (CC): -250.0 – 400.0 B (RH): 20.0 – 1820.0 R: -30.0 – 1760.0 S: -30.0 – 1760.0 C (WRe 5-26): 20.0 – 2315.0 N: -250.0 – 1300.0 U: -180.0 – 600.0 L: -180.0 – 900.0 P (Platinel II): 20.0 – 1395.0	°C	1000.0
	16	Input decimal point	No decimal point The number of decimal places : 1 or 2	—	1 place of decimals
	17	Output range	0 – 20 mA -5 – +5 V -10 – +10 V	—	0 – 20 mA
	18	0 % output setting	0.000 – 19.000 -5.000 – 4.750 -10.000 – 9.000	mA V V	4.000
	19	100 % output setting	1.000 – 20.000 -4.750 – 5.000 -9.000 – 10.000	mA V V	20.000
	20	0 % output scaling	-99999 – 999999	—	0.00
	21	100 % output scaling	-99999 – 999999	—	100.00
	22	Output decimal point	No decimal point The number of decimal places : 1 – 5	—	2 places of decimals
	26	Loop test	-10.00 – 110.00	%	Cancel

[01] Lockout setting

Set Lock / Unlock of lockout setting.

SETTING VALUE	DESCRIPTION	INITIAL VALUE
Lock	Lockout setting enable	Lock
Unlock	Lockout setting disable	

Even when setting is 'Lock', it is available to move on to each setting mode and confirm the setting value of each setting parameter. In each setting parameter display, when 'Lock', 'DATA (Locked)' is indicated, when 'Unlock', 'DATA' is indicated.

[11] Input range

Set the type of T/C connected to the input.

SETTING TYPE	SETTING RANGE			INITIAL VALUE
	°C	°F	K	
(PR)	0.00 – 1760.00	32.00 – 3200.00	273.15 – 2033.15	K (CA)
K (CA)	-270.00 – +1370.00	-454.00 – +2498.00	3.15 – 1643.15	
E (CRC)	-270.00 – +1000.00	-454.00 – +1832.00	3.15 – 1273.15	
J (IC)	-210.00 – +1200.00	-346.00 – +2192.00	63.15 – 1473.15	
T (CC)	-270.00 – +400.00	-454.00 – +752.00	3.15 – 673.15	
B (RH)	0.00 – 1820.00	32.00 – 3308.00	273.15 – 2093.15	
R	-50.00 – +1760.00	-58.00 – +3200.00	223.15 – 2033.15	
S	-50.00 – +1760.00	-58.00 – +3200.00	223.15 – 2033.15	
C (WRe 5-26)	0.00 – +2315.00	32.00 – 4199.00	273.15 – 2588.15	
N	-270.00 – +1300.00	-454.00 – +2372.00	3.15 – 1573.15	
U	-200.00 – +600.00	-328.00 – +1112.00	73.15 – 873.15	
L	-200.00 – +900.00	-328.00 – +1652.00	73.15 – 1173.15	
P (Platinel II)	0.00 – 1395.00	32.00 – 2543.00	273.15 – 1668.15	

[12] 0 % input setting

Set the 0 % input setting for input to the unit.

Setting range differs according to input range.

INPUT RANGE	SETTING RANGE			MINIMUM SPAN		INITIAL VALUE
	°C	°F	K	°C, K	°F	
(PR)	0.00 – 1740.00	32.00 – 3164.00	273.15 – 2013.15	20.00	36.00	0.0
K (CA)	-270.00 – +1350.00	-454.00 – +2462.00	3.15 – 1623.15			
E (CRC)	-270.00 – +980.00	-454.00 – +1796.00	3.15 – 1253.15			
J (IC)	-210.00 – +1180.00	-346.00 – +2156.00	63.15 – 1453.15			
T (CC)	-270.00 – +380.00	-454.00 – +716.00	3.15 – 653.15			
B (RH)	0.00 – 1800.00	32.00 – 3272.00	273.15 – 2073.15			
R	-50.00 – +1740.00	-58.00 – +3164.00	223.15 – 2013.15			
S	-50.00 – +1740.00	-58.00 – +3164.00	223.15 – 2013.15			
C (WRe 5-26)	0.00 – +2295.00	32.00 – 4163.00	273.15 – 2568.15			
N	-270.00 – +1280.00	-454.00 – +2336.00	3.15 – 1553.15			
U	-200.00 – +580.00	-328.00 – +1076.00	73.15 – 853.15			
L	-200.00 – +880.00	-328.00 – +1616.00	73.15 – 1153.15			
P (Platinel II)	0.00 – 1375.00	32.00 – 2507.00	273.15 – 1648.15			

Set as follows.

[12] 0 % input setting < [13] 100 % input setting

[13] 100 % input setting

Set the 100 % input setting for input to the unit.

Setting range differs according to input range.

INPUT RANGE	SETTING RANGE			MINIMUM SPAN		INITIAL VALUE
	°C	°F	K	°C, K	°F	
(PR)	20.00 – 1760.00	68.00 – 3200.00	293.15 – 2033.15	20.00	36.00	1600.0
K (CA)	-250.00 – +1370.00	-418.00 – +2498.00	23.15 – 1643.15			
E (CRC)	-250.00 – +1000.00	-418.00 – +1832.00	23.15 – 1273.15			
J (IC)	-190.00 – +1200.00	-310.00 – +2192.00	83.15 – 1473.15			
T (CC)	-250.00 – +400.00	-418.00 – +752.00	23.15 – 673.15			
B (RH)	20.00 – 1820.00	68.00 – 3308.00	293.15 – 2093.15			
R	-30.00 – +1760.00	-22.00 – +3200.00	243.15 – 2033.15			
S	-30.00 – +1760.00	-22.00 – +3200.00	243.15 – 2033.15			
C (WRe 5-26)	20.00 – +2315.00	68.00 – 4199.00	293.15 – 2588.15			
N	-250.00 – +1300.00	-418.00 – +2372.00	23.15 – 1573.15			
U	-180.00 – +600.00	-292.00 – +1112.00	93.15 – 873.15			
L	-180.00 – +900.00	-292.00 – +1652.00	93.15 – 1173.15			
P (Platinel II)	20.00 – 1395.00	68.00 – 2543.00	293.15 – 1668.15			

Set as follows.

[12] 0 % input setting < [13] 100 % input setting

[16] Input decimal point

Set the decimal point position measurement value.

SETTING VALUE	DESCRIPTION	INITIAL VALUE
oooo	Decimal point: None	1 place of decimals
oooo.o	Number of decimal places: 1	
oooo.oo	Number of decimal places: 2	

When number of digit after the decimal point decreased, hidden digit for [12] 0% input setting and [13] 100% input setting is rounded down.

[17] Output range

Set the range of output signal of the unit.

SETTING VALUE	DESCRIPTION	INITIAL VALUE
0 – 20 mA	Output: 0 – 20 mA DC	0 – 20 mA
-5 – +5 V	Output: -5 – +5 V DC	
-10 – +10 V	Output: -10 – +10 V DC	

When output range is changed, turn the power off, and then set the output setting DIP SW on the side of the unit. Setting is as follows. Output setting value is changed to initial value.

OUTPUT RANGE	SW1							
	1	2	3	4	5	6	7	8
0 – 20 mA	OFF	ON	OFF	OFF	OFF	OFF	ON	OFF
-5 – +5 V	OFF	OFF	ON	OFF	ON	OFF	OFF	ON
-10 – +10 V	OFF	OFF	ON	OFF	OFF	ON	OFF	ON

[18] 0 % output setting

Set the 0 % output setting.

OUTPUT RANGE	SETTING RANGE	MIN. SPAN	INITIAL VALUE
0 – 20 mA	0.000 – 19.000	1.000	4.000
-5 – +5 V	-5.000 – 4.750	0.250	-5.000
-10 – +10 V	-10.000 – 9.000	1.000	-10.000

Set as follows.

[18] 0 % output setting < [19] 100 % output setting

The value is indicated by 'OUTPUT' at measuring mode.

[26] Loop test

As pressing Set button enables to blink 'Cancel', changing to 'Set' by pressing Up or Down and pressing 'Set' allows to indicate Loop Test display.

Present value is indicated. Increase or decrease it by pressing Up and Down button. Press and hold them enables to change value continuously.*1

Pressing and holding Mode button more than 2 seconds or turning off the power enable to exit loop test.

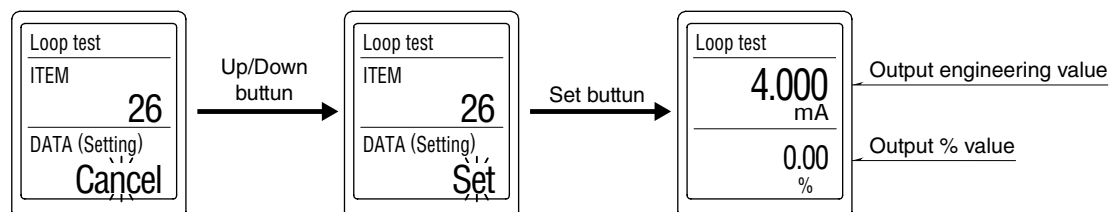

*1. While loop test is performing, actual input is disregarded.

While loop test is performing and 'Display timeout' is enabled to display off, return to the display on by pressing a front button.

[19] 100 % output setting

Set the 100 % output setting.

OUTPUT RANGE	SETTING RANGE	MIN. SPAN	INITIAL VALUE
0 – 20 mA	1.000 – 20.000	1.000	20.000
-5 – +5 V	-4.750 – 5.000	0.250	5.000
-10 – +10 V	-9.000 – 10.000	1.000	10.000

Set as follows.

[18] 0 % output setting < [19] 100 % output setting

The value is indicated by 'OUTPUT' at measuring mode.

[20] 0 % output scaling

Set the display value of [18] 0 % output setting.

SETTING RANGE	INITIAL VALUE
-99999 – 999999	0.00

[21] 100 % output scaling

Set the display value of [19] 100 % output setting.

SETTING RANGE	INITIAL VALUE
-99999 – 999999	100.00

[22] Output decimal point

Set decimal point position for [20] 0 % and [21] 100 % output scaling.

SETTING VALUE	DESCRIPTION	INITIAL VALUE
oooooo	Decimal point: None	2 places of decimals
ooooo.o	Number of decimal places: 1	
oooo.oo	Number of decimal places: 2	
ooo.ooo	Number of decimal places: 3	
oo.oooo	Number of decimal places: 4	
o.ooooo	Number of decimal places: 5	

OPTION MODE

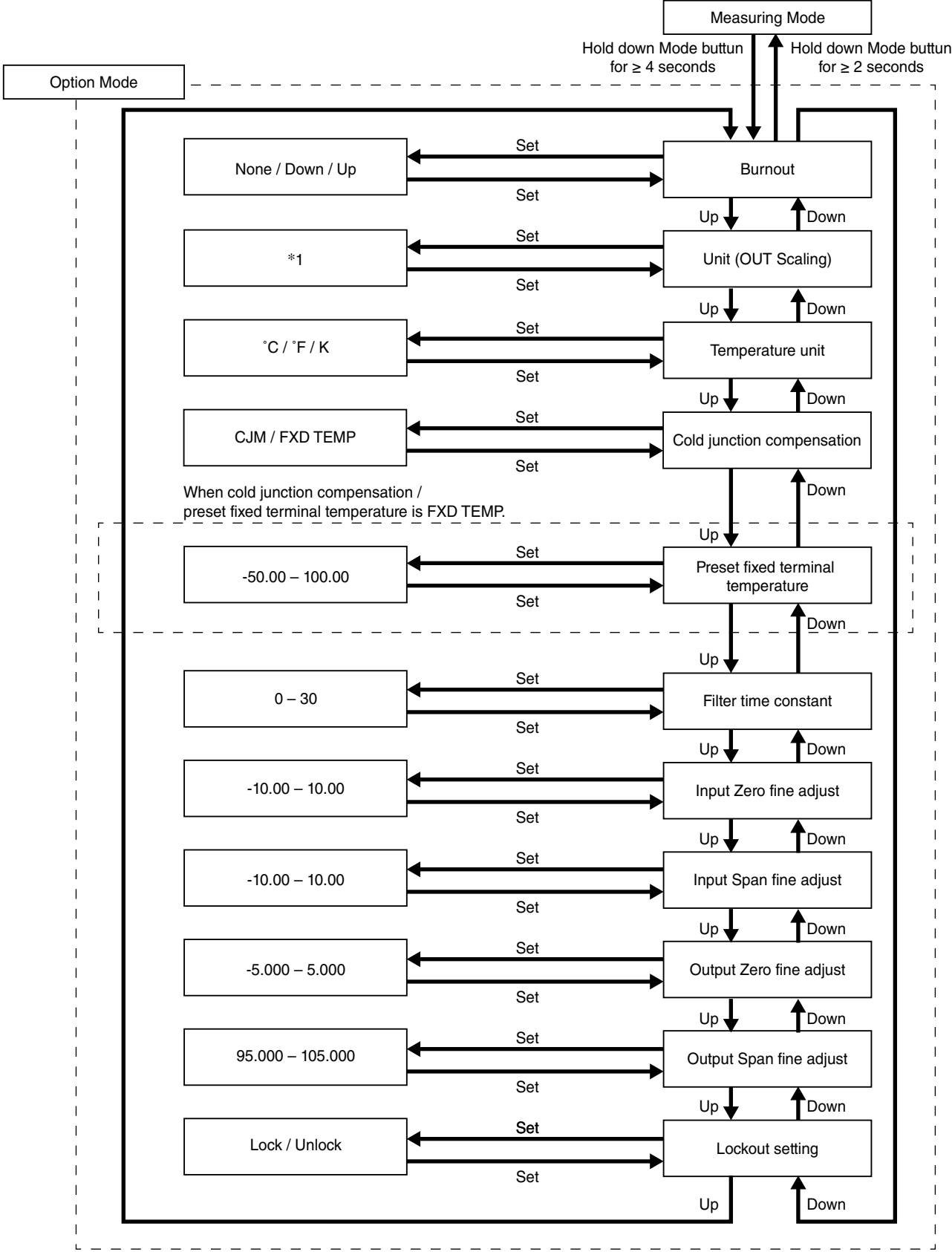

*1. Refer to [61] Unit (OUT scaling) for usable unit.

• Parameters

MODE	ITEM	SETTING PARAMETER	RANGE	UNIT	INITIAL VALUE
Option setting	51	Burnout	None / Down / Up	—	Up
	61	Unit (OUT Scaling)	Choose from 68 types	—	%
	64	Temperature unit	°C / °F / K	—	°C
	65	Cold junction compensation	CJM / FXD TEMP	—	CJM
	66	Preset fixed terminal temperature	-50.00 – 100.00	°C	0.00
	67	Filter time constant	0 – 30	sec.	0
	69	Input Zero fine adjust	-10.00 – 10.00	°C	0.00
	70	Input Span fine adjust	-10.00 – 10.00	°C	0.00
	71	Output Zero fine adjust	-5.000 – 5.000	%	0.000
	72	Output Span fine adjust	95.000 – 105.000	%	100.000
	01	Lockout setting	Lock / Unlock	—	Lock

[51] Burnout

Set the operation at burnout.

SETTING VALUE	DESCRIPTION	INITIAL VALUE
None	No detection	Up
Down	Go downscale	
Up	Go upscale	

[61] Unit (OUT Scaling)

Set the unit to display output scaling.

Available units are following 68 types.

DC, AC, mV, V, kV, μ A, mA, A, kA, mW, W, kW, var, kvar, Mvar, VA, Hz, Ω , k Ω , M Ω , cm, mm, m, m/sec, mm/min, cm/min, m/min, m/h, m/s², inch, L, L/s, L/min, L/h, m³, m³/sec, m³/min, m³/h, Nm³/h, N·m, N/m², g, kg, kg/h, N, kN, Pa, kPa, MPa, t, t/h, °C, °F, K, %RH, J, kJ, MJ, rpm, sec, min, min⁻¹, pH, %, ppm, deg, (blank), User

Selecting 'User' enables to move on to user's unit setting display. A unit can be created by using any characters. Up to 13 characters available.*1 Up and Down button enables to move on selected characters. Set button enables to select a character. While setting, pressing Mode button enables to delete a character, pressing and holding Mode button enables to discard the settings. Pressing and holding Set button enables to determine the setting and return to setting display of [61] Unit (OUT Scaling). The unit is indicated by 'OUTPUT (Scaling)' at measuring mode display.

If turning power off while setting, it returns to setting display of [61] Unit (OUT Scaling) (The setting value is discarded).

*1. Settable characters

0 - 9 A - Z a - z ! " # \$ % & ' () = -
+ * ^ | @ ` [] { } ; : < > ? _ , . /

[64] Temperature unit

Set the temperature unit for the display and setting.

SETTING VALUE	DESCRIPTION	INITIAL VALUE
°C	Celsius	°C
°F	Fahrenheit	
K	Absolute	

[65] Cold junction compensation

Choose the cold junction compensation method.

SETTING VALUE	DESCRIPTION	INITIAL VALUE
CJM	Measuring terminal temp. with CJM	CJM
FXD TEMP	Set fixed terminal temperature	

[66] Preset fixed terminal temperature

When FXD TEMP is chosen with [65] Cold junction compensation, set fixed terminal temperature.

SETTING RANGE			INITIAL VALUE
°C	°F	K	INITIAL VALUE
-50.00 – +100.00	-58.00 – +212.00	223.15 – 373.15	0.00

[67] Filter time constant

Set filter time constant of the first order lag filter.

The first order lag filter is available with setting time.

When '0' is set to this parameter, the first order lag filter is not available (Response time: ≤ 0.5 sec. (0 → 90 %)).

The first order lag filter is equivalent to general CR filter.

The setting time constant is the time to follow until about 63 %, when input varies from 0 % to 100 %.

It is available to set the range between 0 – 30 seconds.

Initial value: 0

[69] Input Zero fine adjust

Perform fine adjustment of input signal.

SETTING RANGE		INITIAL VALUE
°C, K	°F	INITIAL VALUE
-10.00 – +10.00	-18.00 – +18.00	0.00

[70] Input Span fine adjust

Perform fine adjustment of input signal.

SETTING RANGE		INITIAL VALUE
°C, K	°F	INITIAL VALUE
-10.00 – +10.00	-18.00 – +18.00	0.00

[71] Output Zero fine adjust

Perform fine adjustment of output signal. Available range between -5.000 – +5.000 %.

Initial value: 0.000

[72] Output Span fine adjust

Perform fine adjustment of output signal. Available range between 95.000 – 105.000 %.

Initial value: 100.000

[01] Lockout setting

Set Lock / Unlock of lockout setting.

SETTING VALUE	DESCRIPTION	INITIAL VALUE
Lock	Lockout setting enable	Lock
Unlock	Lockout setting disable	

Even when setting is 'Lock', it is available to move on to each setting mode and confirm the setting value of each setting parameter. In each setting parameter display, when 'Lock', 'DATA (Locked)' is indicated, when 'Unlock', 'DATA' is indicated.

■ ADVANCED MODE

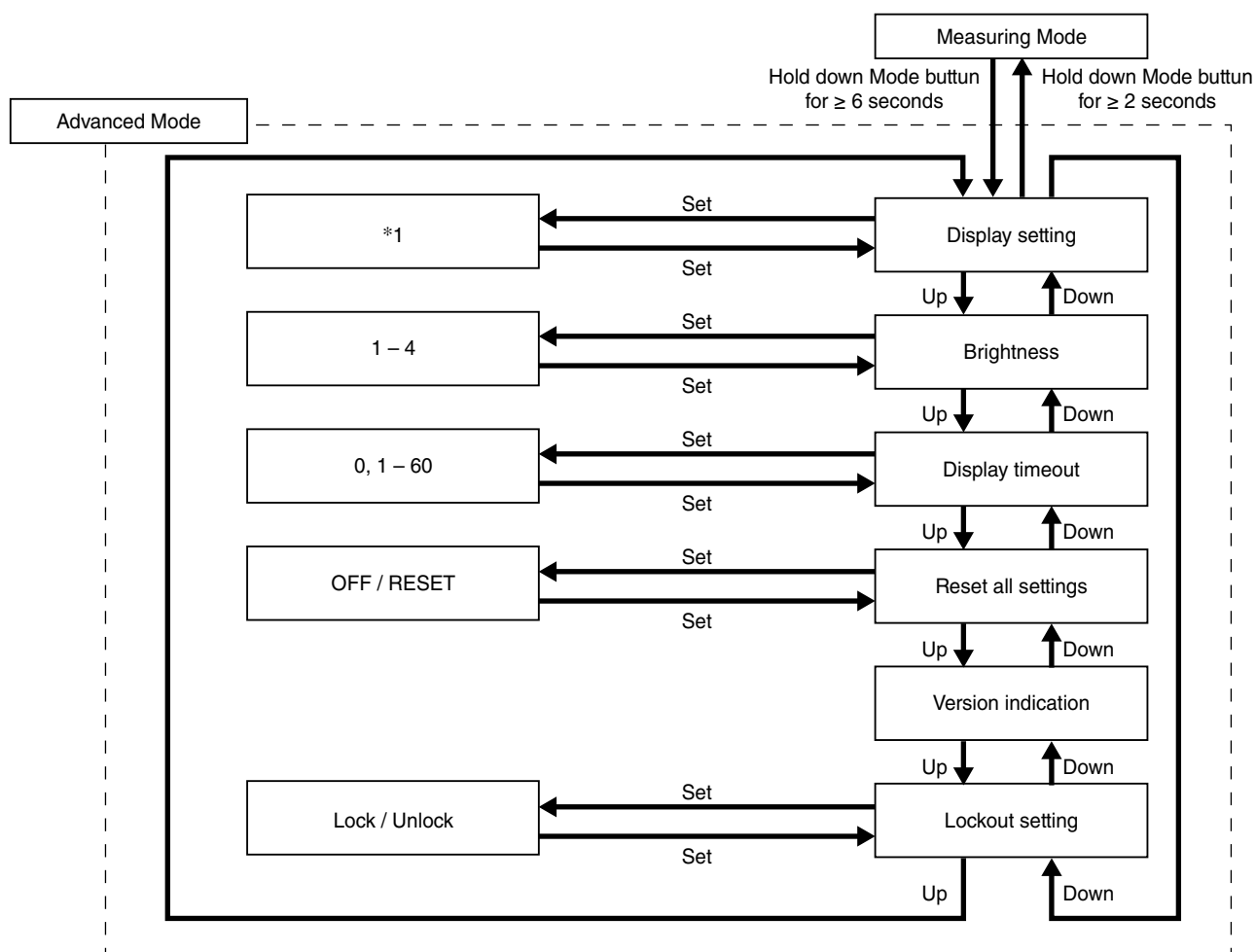

*1. For detail, refer to [90] Display setting.

• Parameters

MODE	ITEM	SETTING PARAMETER	RANGE	UNIT	INITIAL VALUE
Advanced setting	90	Display setting	Upper: choose from 5 types Lower: choose from 6 types	—	Upper: INPUT Lower: PERCENT
	91	Brightness	1 (darkest) – 4 (brightest)	—	4
	92	Display timeout	0 (always on), 1 – 60	min.	10
	93	Reset all settings	OFF / RESET	—	OFF
	94	Version indication	—	—	—
	01	Lockout setting	Lock / Unlock	—	Lock

[90] Display setting

Set display setting in measuring mode. Display is divided, indicating item can be set for each upper and lower. Pressing Set button once is setting for upper, pressing again for lower, pressing once more for setting determined.

Upper

SETTING VALUE	DESCRIPTION	INITIAL VALUE
INPUT	Input engineering unit value	INPUT (engineering value)
VOLTAGE	Input electromotive force value	
PERCENT	Percent value*2	
OUTPUT	Output engineering unit value	
OUTPUT (Scaling)*1	Output scaling	

*1. Display at measuring mode is OUT (Scaling).

*2. Display the value converted as 0.00 to 100.00 % based on input setting value.

Lower

SETTING VALUE	DESCRIPTION	INITIAL VALUE
INPUT	Input engineering unit value	PERCENT (percent value)*2
VOLTAGE	Input electromotive force value	
PERCENT	Percent value*2	
OUTPUT	Output engineering unit value	
OUTPUT (Scaling)*1	Output scaling	
None	No display	

*1. Display at measuring mode is OUT (Scaling).

*2. Display the value converted as 0.00 to 100.00 % based on input setting value.

[91] Brightness

Adjust brightness of display. It is available to set the range between 1 (darkest) – 4 (brightest).

Initial value: 4

[92] Display timeout

Set the time to off the display when there is no operation within a certain time.

It is available to set the range between 0 – 60 minutes.

Set '0' to display 'always on'.

When error is occurred at display off, the display returns from off.

Initial value: 10

[93]Reset all settings

Return settings to initial value.

SETTING VALUE	DESCRIPTION
OFF	Not initialized
RESET	Initialize all settings*1

*1. When setting value is initialized, each parameters currently set are over written by initial value. 'COMPLETE' is indicated when initializing setting value is completed. Notice that it does not return to the setting value, which is specified by the option Ex-factory setting (/SET). Configure initialized value again with DIP switch with power off for output setting.

[94]Version indication

Indicate firmware version.

[01] Lockout Setting

Set Lock / Unlock of lockout setting.

SETTING VALUE	DESCRIPTION	INITIAL VALUE
Lock	Lockout setting enable	Lock
Unlock	Lockout setting disable	

Even when setting is 'Lock', it is available to move on to each setting mode and confirm the setting value of each setting parameter. In each setting parameter display, when 'Lock', 'DATA (Locked)' is indicated, when 'Unlock', 'DATA' is indicated.

ERROR MESSAGES

DISPLAY	ERROR DESCRIPTION	WHAT TO DO
BURNOUT ERROR U	Input wires broken (Output upward)	Check the input wires.
BURNOUT ERROR D	Input wires broken (Output downward)	Check the input wires.
OVER RANGE U	The input exceeds 105 %.	Return the input signal not exceed 105 %.
OVER RANGE D	The input exceeds lower limit of -5 %.	Return the input signal -5 % or more.
SCALING ERROR U	Output scaling value exceeds 999999 (upward).	Return the output signal not exceed 999999..
SCALING ERROR D	Output scaling value exceeds -99999 (downward).	Return the output signal not lower than -99999.
EEPROM I ERROR	Internal data error	Repair is needed if the display does not recover after the power is reset.
EEPROM R ERROR	Memory reading error	'Reset all settings' in advanced mode.*1
EEPROM W ERROR	Memory writing error	'Reset all settings' in advanced mode.*1

*1. All setting parameters are initialized. Repair is needed if it does not recover.

Indicated errors vary as follows depending on setting value of display setting.

Error is indicated blinking at upper or lower.

When multiple error occurs, only high priority error is displayed.

Order of priority is EEPROM ERROR, BURNOUT ERROR, OVER RANGE, SCALING ERROR in descending order.

ERROR MESSAGES		DISPLAY SETTING				
		INPUT ENGINEERING UNIT VALUE	INPUT EMF VALUE	PERCENT VALUE	OUTPUT ENGINEERING UNIT VALUE	OUTPUT SCALING VALUE
BURNOUT ERROR U		✓	✓	—	✓	✓
BURNOUT ERROR D						
OVER RANGE U		✓	✓	—	✓	✓
OVER RANGE D						
SCALING ERROR U (OUTPUT)					✓	✓
SCALING ERROR D (OUTPUT)		—	—	—		
EEPROM I ERROR						
EEPROM R ERROR				✓		
EEPROM W ERROR						

WIRING INSTRUCTIONS

■ SCREW TERMINAL

Torque: 0.8 N·m

■ SOLDERLESS TERMINAL

Refer to the drawing below for recommended ring tongue terminal size. Spade tongue type is also applicable.

Applicable wire size: 0.25 to 1.65 mm² (AWG 22 to 16)

Recommended manufacturer: Japan Solderless Terminal MFG.Co.Ltd, Nichifu Co.,Ltd

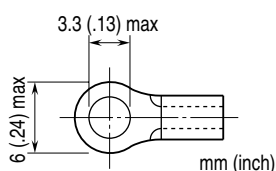

CHECKING

- 1) Terminal wiring: Check that all cables are correctly connected according to the connection diagram.
- 2) Check DIP switch setting.
- 3) Power input voltage: Check voltage across the terminal 10 – 11 with a multimeter.
- 4) Input: Check that the input signal is within 0 – 100% of the full-scale.

If the thermocouple or its extension wires are broken, the output goes over 100% (below 0% with downscale protection) due to burnout function. Confirm the burnout error and check leadwires in such a case.

- 5) Output: Check that the load resistance meets the described specifications.

MAINTENANCE

Regular calibration procedure is explained below:

■ CALIBRATION

Warm up the unit for at least 10 minutes. Apply 0%, 25%, 50%, 75% and 100% input signal. Check that the output signal for the respective input signal remains within accuracy described in the data sheet. If the output signal is out of accuracy, when the input display value is out of accuracy, perform the input fine adjustment. When the input display value is correct but the output is out of accuracy, perform the output fine adjustment. Refer to this manual, when adjusting with front buttons. Refer to the M2E CFG users manual (EM-5147), when adjusting with M2E Configurator Software (model: M2E CFG). And then follow the procedure shown below.

• INPUT FINE ADJUSTMENT

- 1) Set the input signal to 0%, and adjust the input display to 0% by [69] Input Zero fine adjust.
- 2) Set the input signal to 100%, and adjust the input display to 100% by [70] Input Span fine adjust.
- 3) Again set the simulated input to 0%, confirm the input display.
- 4) If input display is shifted, repeat the procedure from 1) to 3).

• OUTPUT FINE ADJUSTMENT

- 1) Set the simulated input to 0%, and adjust the output signal to 0% by [71] Output Zero fine adjust.
- 2) Set the simulated input to 100%, and adjust the output signal to 100% by [72] Output Span fine adjust.
- 3) Again set the simulated input to 0%, confirm the output signal.
- 4) If output signal is shifted, repeat the procedure from 1) to 3).

LIGHTNING SURGE PROTECTION

We offer a series of lightning surge protector for protection against induced lightning surges. Please contact us to choose appropriate models.