

THERMOCOUPLE ALARM
 (PC programmable, dual or quad alarm trip)
MODEL **M2EAXT****CONTENTS**

BEFORE USE	2
POINTS OF CAUTION.....	2
COMPONENT IDENTIFICATION	2
INSTALLATION	3
TERMINAL CONNECTIONS	3
EXTERNAL VIEWS	4
SCREEN DISPLAY.....	5
PROGRAMMING	6
ERROR MESSAGES.....	17
WIRING INSTRUCTIONS.....	18
CHECKING	18
MAINTENANCE.....	18
LIGHTNING SURGE PROTECTION	18

BEFORE USE

Thank you for choosing us. Before use, please check contents of the package you received as outlined below.

If you have any problems or questions with the product, please contact our sales office or representatives.

■ PACKAGE INCLUDES:

Thermocouple alarm
(body + base socket + CJC sensor)(1)

■ MODEL NO.

Confirm Model No. marking on the product to be exactly what you ordered.

■ OPERATING MANUAL

This manual describes detailed operation regarding settings.

The M2EAXT is programmable using a PC. For detailed information on the PC configuration, refer to the M2EACFG users manual (EM-5151).

The M2EACFG Configurator Software is downloadable at our web site.

POINTS OF CAUTION

■ CONFORMITY WITH EU DIRECTIVES

- This equipment is suitable for Pollution Degree 2, Measurement Category II (output, transient voltage 2500V) and Installation Category II (transient voltage 2500V). Prior to installation, check that the insulation class of this unit satisfies the system requirements. Insulation class of this unit is as follows.

Input or output to power	Reinforced insulation (300V)
Input to output	Basic insulation (300V)
L1 or L4 alarm output to L2 or L3 alarm output	Basic insulation (300V)

- Altitude up to 2000 meters.
- The equipment must be mounted inside a panel.
- The equipment must be installed such that appropriate clearance and creepage distances are maintained to conform to CE requirements. Failure to observe these requirements may invalidate the CE conformance.
- The actual installation environments such as panel configurations, connected devices, connected wires, may affect the protection level of this unit when it is integrated in a panel system. The user may have to review the CE requirements in regard to the whole system and employ additional protective measures* to ensure the CE conformity.

* For example, installation of noise filters and clamp filters for the power source, input and output connected to the unit, etc.

- Install lightning surge protectors for those wires connected to remote locations.

■ POWER INPUT RATING & OPERATIONAL RANGE

- Locate the power input rating marked on the product and confirm its operational range as indicated below:

100 – 240V AC rating: 85 – 264V, 47 – 66 Hz,
 ≤ 6VA at 100V AC
 ≤ 7VA at 200V AC
 ≤ 8VA at 264V AC

24V DC rating: 24V ±10%, ≤ 2.5W

110V DC rating: 85 – 150V, ≤ 2.5W

■ GENERAL PRECAUTIONS

- Before you remove the unit from its base socket or mount it, turn off the power supply and input signal for safety.

■ ENVIRONMENT

- Indoor use.
- When heavy dust or metal particles are present in the air, install the unit inside proper housing with sufficient ventilation.
- Do not install the unit where it is subjected to continuous vibration. Do not subject the unit to physical impact.
- Environmental temperature must be within -5 to +55°C (23 to 131°F) with relative humidity within 10 to 85% RH in order to ensure adequate life span and operation.
- Be sure that the ventilation slits are not covered with cables, etc.

■ WIRING

- Do not install cables close to noise sources (relay drive cable, high frequency line, etc.).
- Do not bind these cables together with those in which noises are present. Do not install them in the same duct.

■ AND

- The unit is designed to function as soon as power is supplied, however, a warm up for 10 minutes is required for satisfying complete performance described in the data sheet.
- The edge of the display may be hidden by the frame and invisible depending on the view angle.

COMPONENT IDENTIFICATION

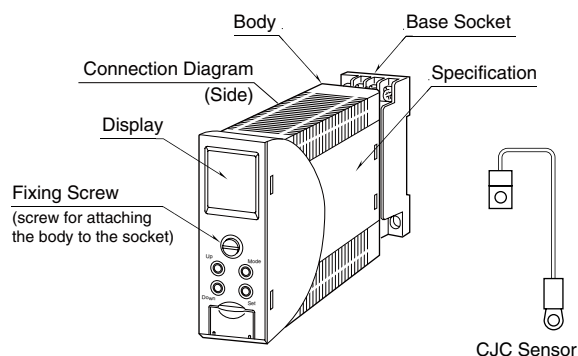

INSTALLATION

Loosen the fixing screw in front of the unit in order to separate the body from the base socket.

■ FIXING SCREW

The fixing screw can be pushed into the body when it is not in use. Tighten the knob until the body is securely attached to the base socket. Push it into the body and turn it clockwise to lock. Push the knob and turn it counterclockwise to unlock so that the knob pops out.

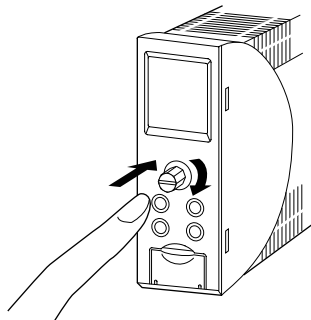

■ DIN RAIL MOUNTING

Set the base socket so that its DIN rail adaptor is at the bottom. Position the upper hook at the rear side of base socket on the DIN rail and push in the lower. When removing the socket, push down the DIN rail adaptor utilizing a minus screwdriver and pull.

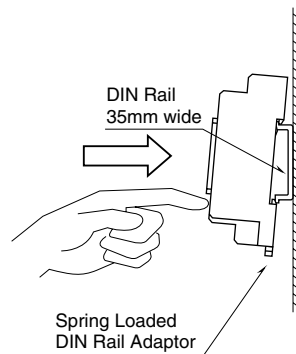

■ WALL MOUNTING

Refer to "EXTERNAL DIMENSIONS."

TERMINAL CONNECTIONS

Connect the unit as in the diagram below or refer to the connection diagram on the side of the unit.

■ EXTERNAL DIMENSIONS unit: mm (inch)

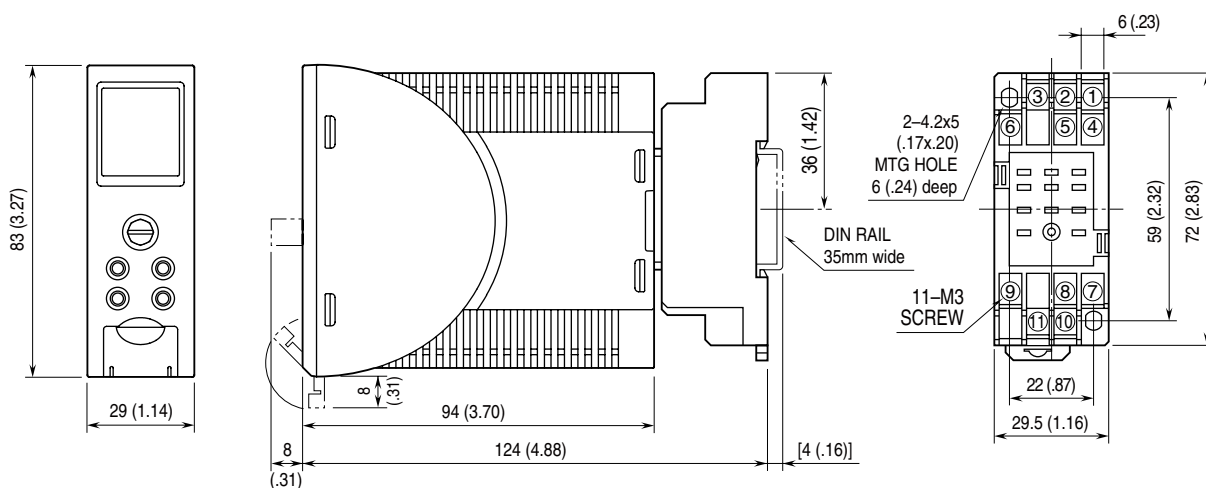

• When mounting, no extra space is needed between units.

■ TERMINAL ASSIGNMENTS

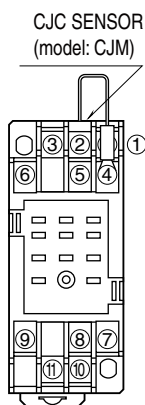

■ CONNECTION DIAGRAM

• Output Code 2: N.O. Relay

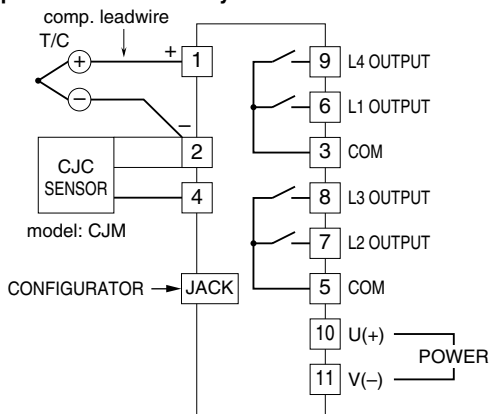

• Output Code 3: N.C. Relay

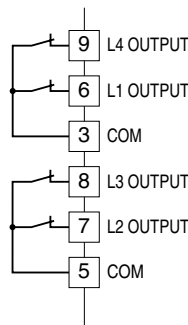

• Output Code 5: SPDT Relay

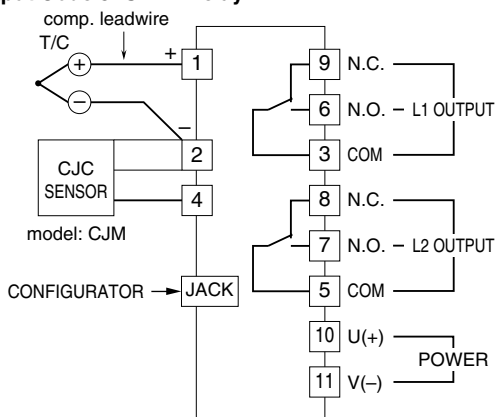

EXTERNAL VIEWS

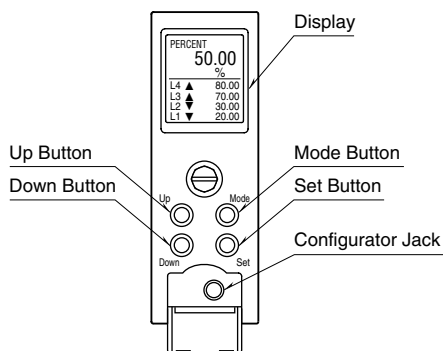

COMPONENT	FUNCTION
Display	Indicates present values, setting values and abnormal information. Two types of present values are displayed respectively at the upper and lower parts according to setting.
Mode button	Shifts from Measuring mode to each setting mode. The destination changes depending on how long the button is held down. Pressing Mode button for ≥ 2 seconds returns to Measuring mode from each setting mode..
Set button	Shifts the setting value of each setting parameter item to a setting changeable state. When at setting changeable state, used to move through the digits of setting value for alarm setpoint and to enter (save) the setting value. Used to release latching alarm in measuring mode (press and hold for 2 sec. or more).
Up button	Shifts through setting parameter items and to increase or select the setting value.
Down button	Shifts through setting parameter items and to decrease or select the setting value.
Configurator Jack	Used to perform configuration with M2EA configurator software (model: M2EACFG). When using the software, set the Lockout setting of the unit to 'Lock'.

SCREEN DISPLAY

■ DISPLAY IN MEASURING MODE

• Double tiered display

The unit can display any two items selected out of input engineering value, input electromotive force value, % value, and alarm.

The value and alarm setting value are highlighted when the alarm is tripped (only when ALARM is set at the lower part).

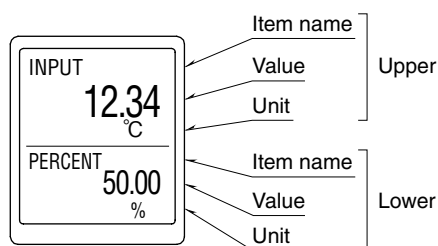
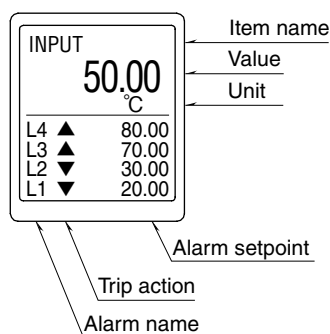

• Single tiered display

When there is only one item selected, the value can be displayed in large characters.

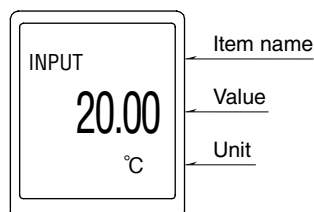

Refer to the settings of Advanced mode for details.

■ DISPLAY IN EACH SETTING MODE

In each setting mode, setting parameter item name, item No., and setting value are indicated.

During setting, '(Setting)' is indicated next to 'DATA'.

If the power is mistakenly shut down during setting, the set value is discarded and returns to the value before setting change.

Setting display previously displayed before power shut-down is indicated at next power up.

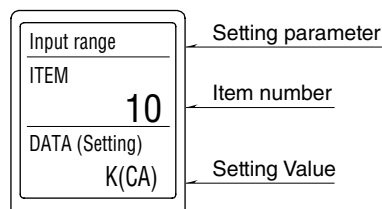

The long parameter item name is scrolled and displayed.

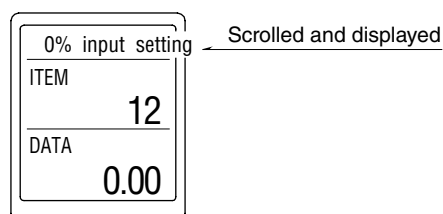

■ DISPLAY TIMEOUT

When there is no operation within the preset display timeout period, the display is cleared (display off).

Pressing Mode, Set, Up, or Down button or occurrence of an alarm or error restores the display from display off.

Set to '0' to keep the display 'always on'.

PROGRAMMING

■ SETTING FLOWCHART

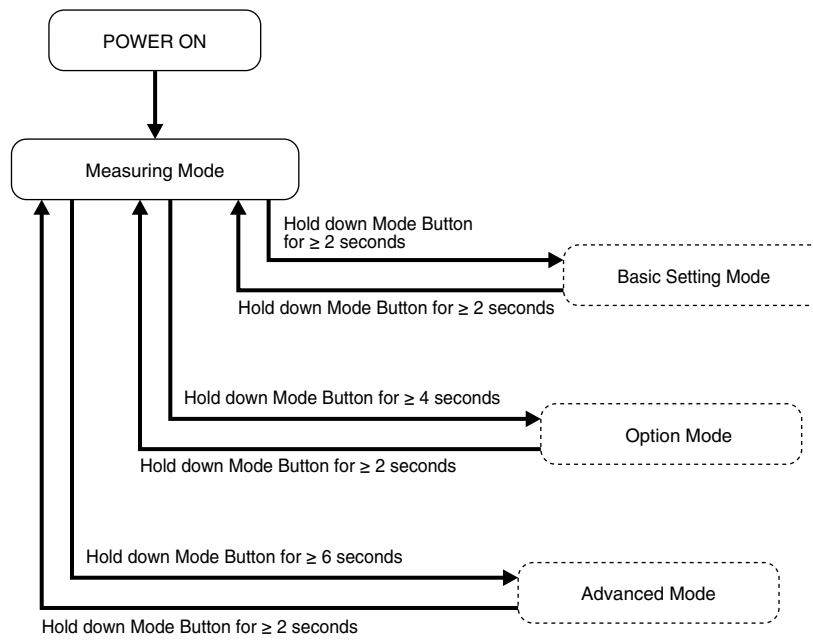

■ OPERATION IN EACH SETTING MODE

• Basic operation

Mode button:	In measuring mode, holding down Mode button for ≥ 2 seconds, ≥ 4 seconds, or ≥ 6 seconds enables to move on to each setting mode. Holding down Mode button for ≥ 2 seconds at each setting item display enables to return to measuring mode. Holding down Mode button for ≥ 2 seconds while changing settings ('(Setting)' is displayed next to 'DATA') enables to discard setting value in changing, and to return to the state before change settings ('(Setting)' next to 'DATA' is off).
Set button:	Pressing Set button at each setting parameter enables to blink setting value and changing settings is ready ('(Setting)' is displayed next to 'DATA'). Pressing Set button while changing settings enables to save (enter) setting value and change from blinking to on.
Up button:	Press Up button to move through setting parameters. Selecting setting value while changing settings, increasing a setting value to set value. Keeping pressing Up button enables to increase the value continuously.
Down button:	Press Down button to move through setting parameters. Selecting setting value while changing settings, decreasing a setting value to set value. Keeping pressing Down button enables to decrease the value continuously.

Note: DO NOT press 2 or more buttons simultaneously.

• Alarm setting parameter

For alarm setting parameter, set values digit by digit. Pressing Set button enables to move blinking digit. Adjust blinking digit to set numerical value with Up and Down button. Blinking digit moves from most significant digit with pressing Set button. At least significant digit, pressing Set button again enables to turn on and determine the setting value. During setting, press and hold Mode button for ≥ 2 seconds to discard the setting value.

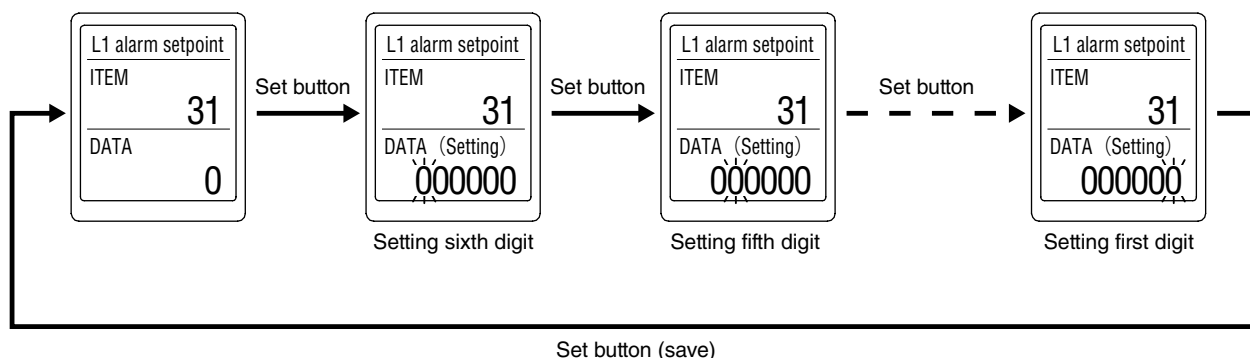

• Lockout setting

'Lockout setting' is available for the unit. When unlocking the lockout setting, indicate 'Lockout Setting' of 'ITEM 01' in each setting mode and set 'Unlock'. To enable lockout setting again, set 'Lock'. Even when lockout setting is enabled, it is available to confirm the each setting value. 'DATA (Locked)' is indicated in that case.

■ BASIC SETTING MODE

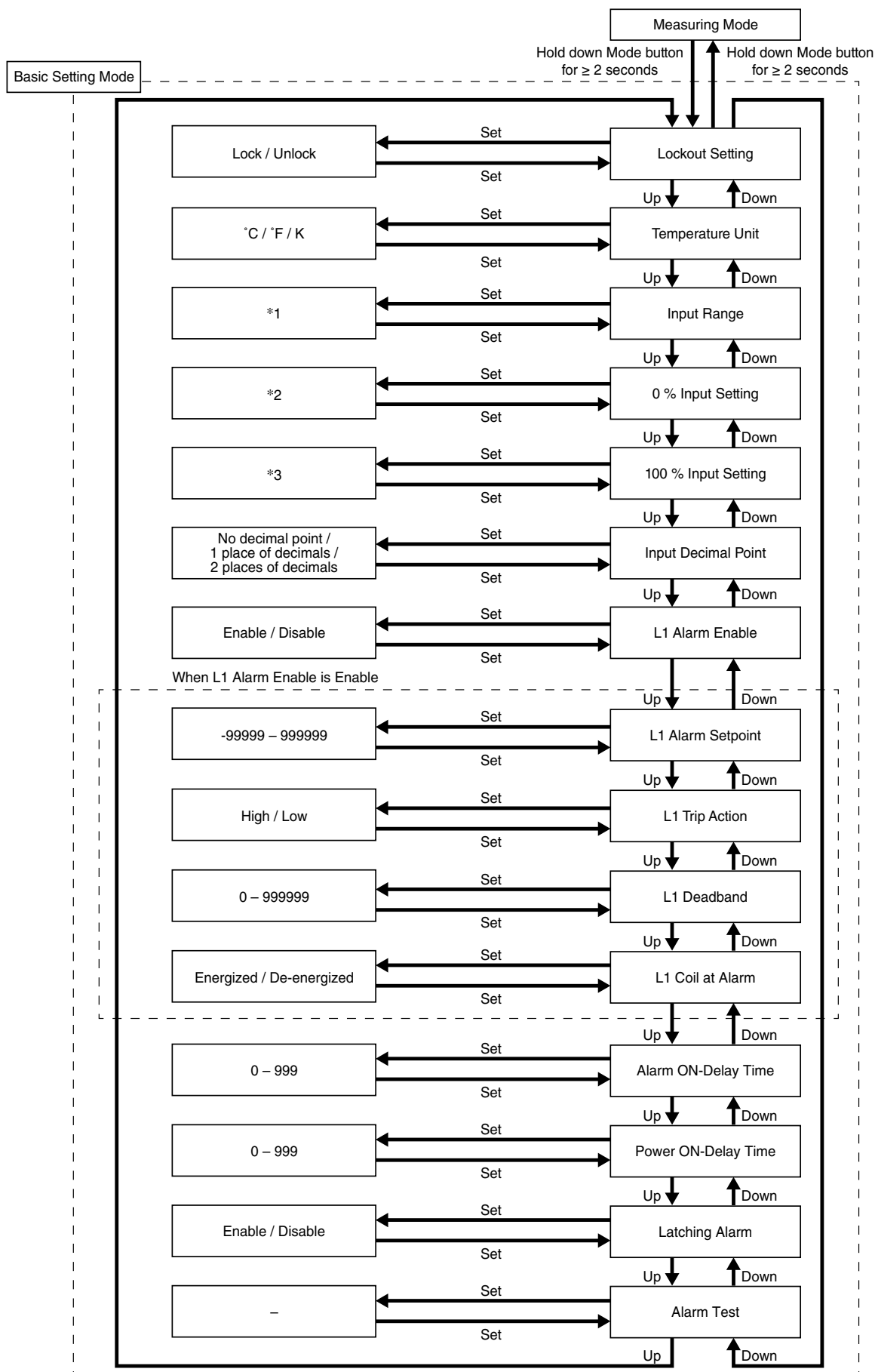

*1. Regarding available input range, refer to [10] Input range.

*2. Available range differs according to input type. Refer to [12] 0 % input setting.

*3. Available range differs according to input type. Refer to [13] 100 % input setting.

Note: Regarding L1 alarm enable, L1 alarm setpoint, L1 trip action, L1 deadband and L1 coil at alarm, same action for L2, L3, and L4.

• Parameters

MODE	ITEM	SETTING PARAMETER	RANGE	UNIT	INITIAL VALUE
Basic setting	01	Lockout setting	Lock / Unlock	—	Lock
	09	Temperature unit	°C / °F / K	—	°C
	10	Input range	(PR) K (CA) E (CRC) J (IC) T (CC) B (RH) R S C (WRe 5-26) N U L P (Platinel II)	—	K (CA)
	12	0 % input setting	(PR): 0.0 – 1740.0	°C	0.0
			K (CA): -270.0 – 1350.0		
			E (CRC): -270.0 – 980.0		
			J (IC): -210.0 – 1180.0		
			T (CC): -270.0 – 380.0		
			B (RH): 0.0 – 1800.0		
			R: -50.0 – 1740.0		
			S: -50.0 – 1740.0		
			C (WRe 5-26): 0.0 – 2295.0		
			N: -270.0 – 1280.0		
			U: -200.0 – 580.0		
	L: -200.0 – 880.0				
	P (Platinel II): 0.0 – 1375.0				
	13	100 % input setting	(PR): 20.0 – 1760.0	°C	1000.0
			K (CA): -250.0 – 1370.0		
			E (CRC): -250.0 – 1000.0		
			J (IC): -190.0 – 1200.0		
T (CC): -250.0 – 400.0					
B (RH): 20.0 – 1820.0					
R: -30.0 – 1760.0					
S: -30.0 – 1760.0					
C (WRe 5-26): 20.0 – 2315.0					
N: -250.0 – 1300.0					
U: -180.0 – 600.0					
L: -180.0 – 900.0					
P (Platinel II): 20.0 – 1395.0					
16	Input decimal point	No decimal point The number of decimal places : 1 or 2	—	1 place of decimals	
30	L1 alarm enable	Disable / Enable	—	Enable	
31	L1 alarm setpoint	-99999 – 999999	—	200.0	
32	L1 trip action	High / Low	—	Low	
33	L1 deadband	0 – 999999	—	1.0	
34	L1 coil at alarm	Energized / De-energized	—	Energized	
40	L2 alarm enable	Disable / Enable	—	Enable	
41	L2 alarm setpoint	-99999 – 999999	—	800.0 (2 points alarm) 300.0 (4 points alarm)	
42	L2 trip action	High / Low	—	High (2 points alarm) Low (4 points alarm)	
43	L2 deadband	0 – 999999	—	1.0	
44	L2 coil at alarm	Energized / De-energized	—	Energized	

MODE	ITEM	SETTING PARAMETER	RANGE	UNIT	INITIAL VALUE
Basic setting	50	L3 alarm enable	Disable / Enable	—	Enable
	51	L3 alarm setpoint	-99999 – 999999	—	700.0
	52	L3 trip action	High / Low	—	High
	53	L3 deadband	0 – 999999	—	1.0
	54	L3 coil at alarm	Energized / De-energized	—	Energized
	60	L4 alarm enable	Disable / Enable	—	Enable
	61	L4 alarm setpoint	-99999 – 999999	—	800.0
	62	L4 trip action	High / Low	—	High
	63	L4 deadband	0 – 999999	—	1.0
	64	L4 coil at alarm	Energized / De-energized	—	Energized
	70	Alarm ON-delay time	0 – 999	sec.	0
	71	Power ON-delay time	0 – 999	sec.	5
	72	Latching alarm	Disable / Enable	—	Disable
	89	Alarm test	—	—	Cancel

[01] Lockout Setting

Set Lock / Unlock of lockout setting.

SETTING VALUE	DESCRIPTION	INITIAL VALUE
Lock	Lockout setting enable	Lock
Unlock	Lockout setting disable	

Even when setting is 'Lock', it is available to move on to each setting mode and confirm the setting value of each setting parameter. In each setting parameter display, when 'Lock', 'DATA (Locked)' is indicated, when 'Unlock', 'DATA' is indicated.

[09] Temperature unit

Set the temperature unit for the display and setting.

SETTING VALUE	DESCRIPTION	INITIAL VALUE
°C	Celsius	°C
°F	Fahrenheit	
K	Absolute	

[10] Input range

Set the type of T/C connected to the input.

SETTING TYPE	SETTING RANGE			INITIAL VALUE
	°C	°F	K	
(PR)	0.00 – 1760.00	32.00 – 3200.00	273.15 – 2033.15	K (CA)
K (CA)	-270.00 – +1370.00	-454.00 – +2498.00	3.15 – 1643.15	
E (CRC)	-270.00 – +1000.00	-454.00 – +1832.00	3.15 – 1273.15	
J (IC)	-210.00 – +1200.00	-346.00 – +2192.00	63.15 – 1473.15	
T (CC)	-270.00 – +400.00	-454.00 – +752.00	3.15 – 673.15	
B (RH)	0.00 – 1820.00	32.00 – 3308.00	273.15 – 2093.15	
R	-50.00 – +1760.00	-58.00 – +3200.00	223.15 – 2033.15	
S	-50.00 – +1760.00	-58.00 – +3200.00	223.15 – 2033.15	
C (WRe 5-26)	0.00 – +2315.00	32.00 – 4199.00	273.15 – 2588.15	
N	-270.00 – +1300.00	-454.00 – +2372.00	3.15 – 1573.15	
U	-200.00 – +600.00	-328.00 – +1112.00	73.15 – 873.15	
L	-200.00 – +900.00	-328.00 – +1652.00	73.15 – 1173.15	
P (Platinel II)	0.00 – 1395.00	32.00 – 2543.00	273.15 – 1668.15	

[12] 0 % input setting

Set the 0 % input setting for input to the unit.

Setting range differs according to input range.

INPUT RANGE	SETTING RANGE			MINIMUM SPAN		INITIAL VALUE
	°C	°F	K	°C, K	°F	
(PR)	0.00 – 1740.00	32.00 – 3164.00	273.15 – 2013.15	20.00	36.00	0.0
K (CA)	-270.00 – +1350.00	-454.00 – +2462.00	3.15 – 1623.15			0.0
E (CRC)	-270.00 – +980.00	-454.00 – +1796.00	3.15 – 1253.15			0.0
J (IC)	-210.00 – +1180.00	-346.00 – +2156.00	63.15 – 1453.15			0.0
T (CC)	-270.00 – +380.00	-454.00 – +716.00	3.15 – 653.15			0.0
B (RH)	0.00 – 1800.00	32.00 – 3272.00	273.15 – 2073.15			500.0
R	-50.00 – +1740.00	-58.00 – +3164.00	223.15 – 2013.15			500.0
S	-50.00 – +1740.00	-58.00 – +3164.00	223.15 – 2013.15			0.0
C (WRe 5-26)	0.00 – +2295.00	32.00 – 4163.00	273.15 – 2568.15			0.0
N	-270.00 – +1280.00	-454.00 – +2336.00	3.15 – 1553.15			0.0
U	-200.00 – +580.00	-328.00 – +1076.00	73.15 – 853.15			0.0
L	-200.00 – +880.00	-328.00 – +1616.00	73.15 – 1153.15			0.0
P (Platinel II)	0.00 – 1375.00	32.00 – 2507.00	273.15 – 1648.15			0.0

Set as follows.

*1. [12] 0 % input setting < [13] 100 % input setting

*2. When input setting value is changed, confirm the alarm set point.

[13] 100 % input setting

Set the 100 % input setting for input to the unit.

Setting range differs according to input range.

INPUT RANGE	SETTING RANGE			MINIMUM SPAN		INITIAL VALUE
	°C	°F	K	°C, K	°F	
(PR)	20.00 – 1760.00	68.00 – 3200.00	293.15 – 2033.15	20.00	36.00	1600.0
K (CA)	-250.00 – +1370.00	-418.00 – +2498.00	23.15 – 1643.15			1000.0
E (CRC)	-250.00 – +1000.00	-418.00 – +1832.00	23.15 – 1273.15			500.0
J (IC)	-190.00 – +1200.00	-310.00 – +2192.00	83.15 – 1473.15			500.0
T (CC)	-250.00 – +400.00	-418.00 – +752.00	23.15 – 673.15			300.0
B (RH)	20.00 – 1820.00	68.00 – 3308.00	293.15 – 2093.15			1600.0
R	-30.00 – +1760.00	-22.00 – +3200.00	243.15 – 2033.15			1600.0
S	-30.00 – +1760.00	-22.00 – +3200.00	243.15 – 2033.15			1600.0
C (WRe 5-26)	20.00 – +2315.00	68.00 – 4199.00	293.15 – 2588.15			2000.0
N	-250.00 – +1300.00	-418.00 – +2372.00	23.15 – 1573.15			1000.0
U	-180.00 – +600.00	-292.00 – +1112.00	93.15 – 873.15			300.0
L	-180.00 – +900.00	-292.00 – +1652.00	93.15 – 1173.15			500.0
P (Platinel II)	20.00 – 1395.00	68.00 – 2543.00	293.15 – 1668.15			1200.0

Set as follows.

*1. [12] 0 % input setting < [13] 100 % input setting

*2. When input setting value is changed, confirm the alarm set point.

[16] Input decimal point

Set the decimal point position measurement value.

SETTING VALUE	DESCRIPTION	INITIAL VALUE
oooo	Decimal point: None	1 place of decimals
oooo.o	Number of decimal places: 1	
oooo.oo	Number of decimal places: 2	

When number of digit after the decimal point decreased, hidden digit for [12] 0 % input setting and [13] 100 % input setting is rounded down.

[30] L1 alarm enable / [40] L2 alarm enable / [50] L3 alarm enable / [60] L4 alarm enable

Set enable/disable of alarm.

SETTING VALUE	DESCRIPTION	INITIAL VALUE
Enable	Provide alarm output	Enable
Disable	Not provide alarm output	

When 'L1 alarm enable' is set to Disable, setting item of L1 alarm can not be set except 'L1 alarm enable'.

The item of L1 alarm is not displayed in the alarm display of Measuring Mode.

[31] L1 alarm setpoint / [41] L2 alarm setpoint / [51] L3 alarm setpoint / [61] L4 alarm setpoint

Set the threshold level to determine the alarm. Set with engineering unit value.

SETTING RANGE	INITIAL VALUE
-99999 – 999999*1	L1 200.0
	L2 800.0 (2 points alarm)
	300.0 (4 points alarm)
	L3 700.0
	L4 800.0

*1. Set within the range between [12] 0 % input setting and [13] 100 % input setting.

[32] L1 trip action / [42] L2 trip action / [52] L3 trip action / [62] L4 trip action

Set high or low for direction of alarm trip action.

SETTING VALUE	DESCRIPTION	INITIAL VALUE
High	High	L1: Low
Low	Low	L2: High (2 points alarm)
		Low (4 points alarm)
		L3, L4: High

[89] Alarm test

As pressing Set button enables to blink 'Cancel', changing to 'Set' by pressing Up or Down and pressing 'Set' allows to indicate Alarm Test display.

The name of alarm selected is shown with inverted display. Press 'Set' button to switch alarm output ON/OFF. Press 'Up' or 'Down' button to switch the alarm selected.*1

Pressing and holding Mode button more than 2 seconds or turning off the power enable to exit Alarm test.

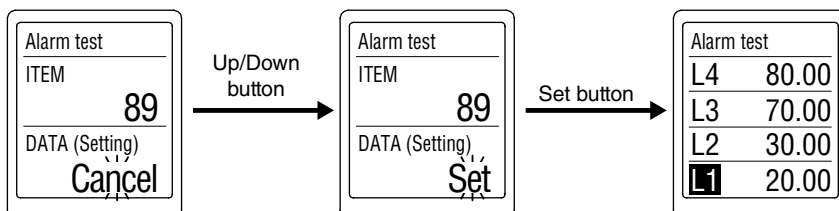

*1. While alarm test is performing, actual input is disregarded.

While alarm test is performing and 'Display timeout' is enabled to display off, return to the display on by pressing a front button.

[33] L1 deadband / [43] L2 deadband / [53] L3 deadband / [63] L4 deadband

Set the deadband when alarm is off.

SETTING RANGE	INITIAL VALUE
0 – 999999*1	1.0

*1. Set the range up to max. value of setting input range.

[34] L1 coil at alarm / [44] L2 coil at alarm / [54] L3 coil at alarm / [64] L4 coil at alarm

Set the output logic of alarm. The logic is inverted when de-energized.

SETTING VALUE	DESCRIPTION	INITIAL VALUE
Energized	Energized	Energized
De-energized	De-energized	

[70] Alarm ON-delay time

Set the delay time for alarm action in second (Common for L1 to L4).

SETTING RANGE	INITIAL VALUE
0 – 999	0

[71] Power ON-delay time

Set the delay time for alarm action when power is turned on in second.

SETTING RANGE	INITIAL VALUE
0 – 999	5

[72] Latching alarm

Set disable/enable for latching alarm.

SETTING VALUE	DESCRIPTION	INITIAL VALUE
Enable	Enable	Disable
Disable	Disable	

To release latching alarm, turn the power of the unit off or set to disable. Or press and hold 'Set' button more than 2 second to release.

■ OPTION MODE

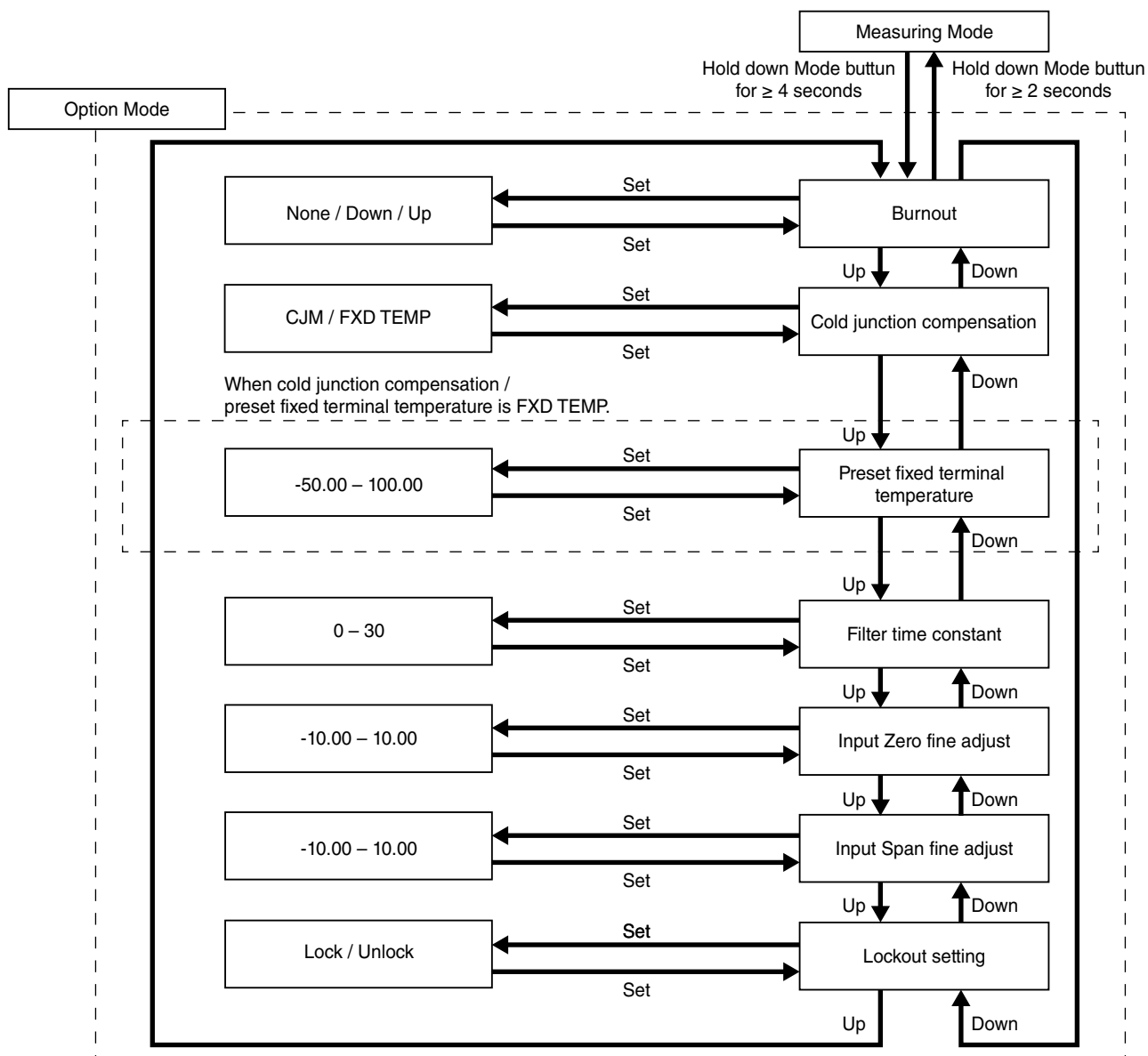

• Parameters

MODE	ITEM	SETTING PARAMETER	RANGE	UNIT	INITIAL VALUE
Option	74	Burnout	None / Down / Up	—	Up
	77	Cold junction compensation	CJM / FXD TEMP	—	CJM
	78	Preset fixed terminal temperature	-50.00 - 100.00	°C	0.00
	79	Filter time constant	0 - 30	sec.	0
	80	Input Zero fine adjust	-10.00 - 10.00	°C	0.00
	81	Input Span fine adjust	-10.00 - 10.00	°C	0.00
	01	Lockout setting	Lock / Unlock	—	Lock

[74] Burnout

Set the operation at burnout.

SETTING VALUE	DESCRIPTION	INITIAL VALUE
None	No detection	Up
Down	Go downscale	
Up	Go upscale	

[77] Cold junction compensation

Choose the cold junction compensation method.

SETTING VALUE	DESCRIPTION	INITIAL VALUE
CJM	Measuring terminal temp. with CJM	CJM
FXD TEMP	Set fixed terminal temperature	

[78] Preset fixed terminal temperature

When FXD TEMP is chosen with [77] Cold junction compensation, set fixed terminal temperature.

SETTING RANGE			INITIAL VALUE
°C	°F	K	
-50.00 – +100.00	-58.00 – +212.00	223.15 – 373.15	0.00

[79] Filter time constant

Set filter time constant of the first order lowpass filter.

The first order lowpass filter is available with setting time.

When '0' is set to this parameter, the filtering process is not performed (Response time: ≤ 0.5 sec. (0 – 100 % at 90 % setpoint)).

The setting time constant is the time to follow until about 63 %, when input varies from 0 % to 100 %.

It is available to set the range between 0 – 30 seconds.

Initial value: 0

[80] Input Zero fine adjust

Perform fine adjustment of input signal.

SETTING RANGE		INITIAL VALUE
°C, K	°F	
-10.00 – +10.00	-18.00 – +18.00	0.00

[81] Input Span fine adjust

Perform fine adjustment of input signal.

SETTING RANGE		INITIAL VALUE
°C, K	°F	
-10.00 – +10.00	-18.00 – +18.00	0.00

[01] Lockout Setting

Set Lock / Unlock of lockout setting.

SETTING VALUE	DESCRIPTION	INITIAL VALUE
Lock	Lockout setting enable	Lock
Unlock	Lockout setting disable	

Even when setting is 'Lock', it is available to move on to each setting mode and confirm the setting value of each setting parameter. In each setting parameter display, when 'Lock', 'DATA (Locked)' is indicated, when 'Unlock', 'DATA' is indicated.

■ ADVANCED MODE

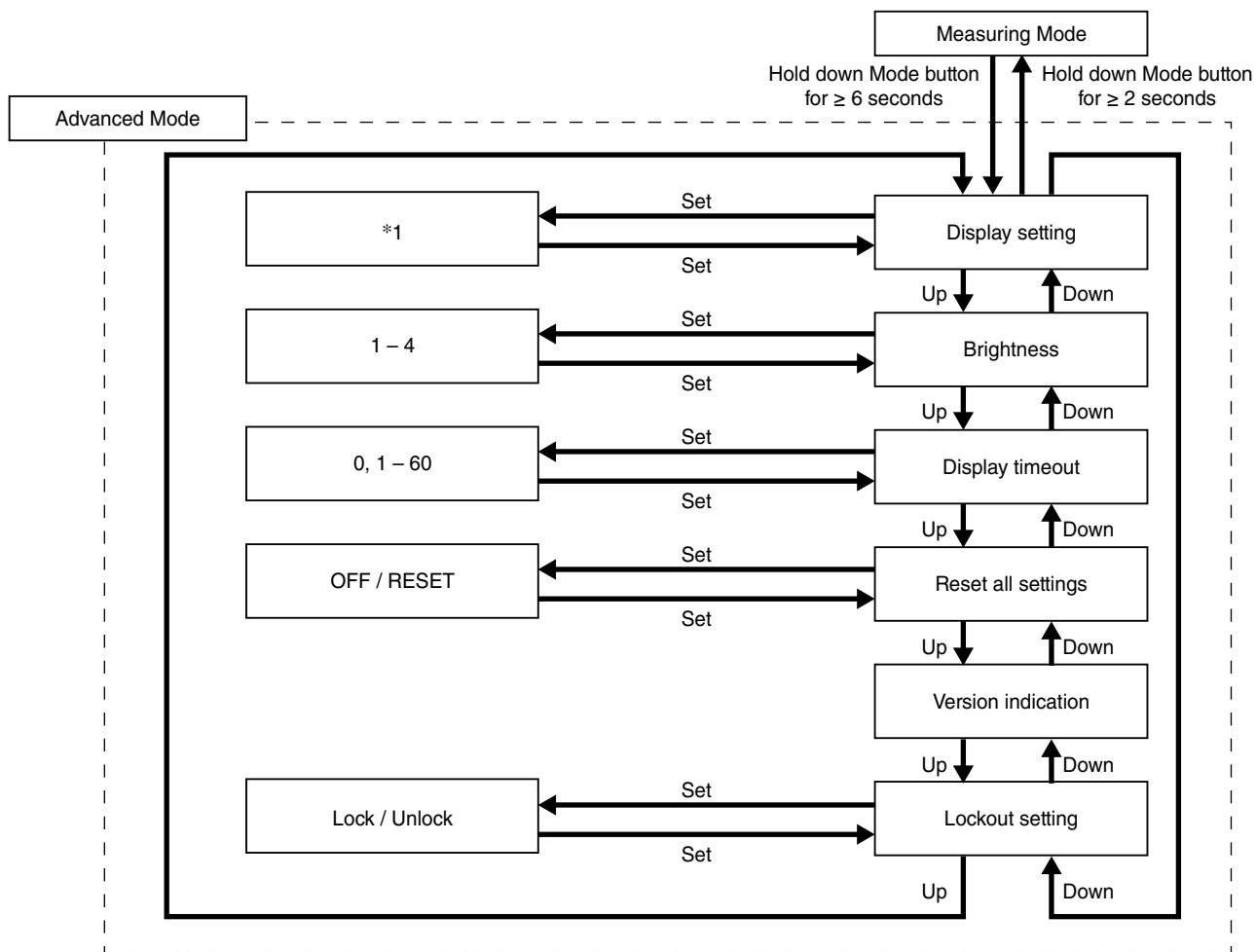

*1. For detail, refer to the [91] Display setting.

• Parameters

MODE	ITEM	SETTING PARAMETER	RANGE	UNIT	INITIAL VALUE
Advanced	91	Display setting	Upper: choose from 3 types Lower: choose from 5 types	—	Upper: INPUT Lower: ALARM
	92	Brightness	1 (darkest) – 4 (brightest)	—	4
	93	Display timeout	0 (always on), 1 – 60	min.	10
	94	Reset all settings	OFF / RESET	—	OFF
	95	Version indication	—	—	—
	01	Lockout setting	Lock / Unlock	—	Lock

[91] Display setting

Set display setting in measuring mode. Display is divided, indicating item can be set for each upper and lower.

Pressing Set button once is setting for upper, pressing again for lower, pressing once more for setting determined.

Upper

SETTING VALUE	DESCRIPTION	INITIAL VALUE
INPUT	Input engineering unit value	INPUT
VOLTAGE	Input electromotive force value	
PERCENT	Percent value*1	

*1. Display the value converted as 0.00 to 100.00 % based on input setting value.

Lower

SETTING VALUE	DESCRIPTION	INITIAL VALUE
ALARM	Alarm	ALARM
INPUT	Input engineering unit value	
VOLTAGE	Input electromotive force value	
PERCENT	Percent value*1	
None	No display	

*1. Display the value converted as 0.00 to 100.00 % based on input setting value.

[92] Brightness

Adjust brightness of display. It is available to set the range between 1 (darkest) – 4 (brightest).

Initial value: 4

[93] Display timeout

Set the time to off the display when there is no operation within a certain time.

It is available to set the range between 0 – 60 minutes.

Set '0' to display 'always on'.

When error is occurred at display off, the display returns from off.

Initial value: 10

[94] Reset all settings

Return settings to initial value.

SETTING VALUE	DESCRIPTION
OFF	Not initialized
RESET	Initialize all settings*1

*1. When setting value is initialized, each parameters currently set are over written by initial value. 'COMPLETE' is indicated when initializing setting value is completed. Notice that it does not return to the setting value, which is specified by the option Ex-factory setting (/SET).

[95] Version indication

Indicate firmware version.

[01] Lockout Setting

Set Lock / Unlock of lockout setting.

SETTING VALUE	DESCRIPTION	INITIAL VALUE
Lock	Lockout setting enable	Lock
Unlock	Lockout setting disable	

Even when setting is 'Lock', it is available to move on to each setting mode and confirm the setting value of each setting parameter. In each setting parameter display, when 'Lock', 'DATA (Locked)' is indicated, when 'Unlock', 'DATA' is indicated.

ERROR MESSAGES

DISPLAY	ERROR DESCRIPTION	WHAT TO DO
BURNOUT ERROR U	Input wires broken (upward)	Check the input wires.
BURNOUT ERROR D	Input wires broken (downward)	Check the input wires.
OVER RANGE U	The input exceeds 105 %.	Return the input signal not exceed 105 %.
OVER RANGE D	The input exceeds lower limit of -5 %.	Return the input signal -5 % or more.
EEPROM I ERROR	Internal data error	Repair is needed if the display does not recover after the power is reset.
EEPROM R ERROR	Memory reading error	'Reset all settings' in advanced mode.*1
EEPROM W ERROR	Memory writing error	'Reset all settings' in advanced mode.*1
ADC ERROR	AD converter error	Repair is needed if the display does not recover after the power is reset.

*1. All setting parameters are initialized. Repair is needed if it does not recover.

Indicated errors vary as follows depending on setting value of display setting.

Error is indicated blinking at upper or lower.

When multiple error occurs, only high priority error is displayed.

Order of priority is EEPROM ERROR, ADC ERROR, OVER RANGE in descending order.

ERROR MESSAGES	DISPLAY SETTING		
	INPUT ENGINEERING UNIT VALUE	INPUT EMF VALUE	PERCENT VALUE
BURNOUT ERROR U	✓	✓	—
BURNOUT ERROR D			
OVER RANGE U	✓	✓	—
OVER RANGE D			
EEPROM I ERROR		✓	
EEPROM R ERROR			
EEPROM W ERROR			
ADC ERROR			

WIRING INSTRUCTIONS

■ SCREW TERMINAL

Torque: 0.8 N·m

■ SOLDERLESS TERMINAL

Refer to the drawing below for recommended ring tongue terminal size. Spade tongue type is also applicable.

Applicable wire size: 0.25 to 1.65 mm² (AWG 22 to 16)

Recommended manufacturer: Japan Solderless Terminal MFG.Co.Ltd, Nichifu Co.,Ltd

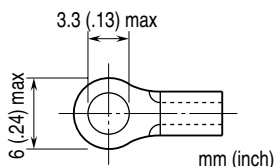

CHECKING

- 1) Terminal wiring: Check that all cables are correctly connected according to the connection diagram.
- 2) Power input voltage: Check voltage across the terminal 10 – 11 with a multimeter.
- 3) Input: Check that the input signal is within 0 – 100% of full-scale.

If the thermocouple or its extension wires are broken, the burnout error is indicated due to burnout function. Check the leadwires in such a case.

- 4) Alarm operations: Check the alarm operations referring to the figure below.
- 5) Output load: Check that the output load is 250 V AC/ 120 VA or 125 V DC/30 W (250 V AC/480 VA or 125 V DC/ 150 W for dual alarm, Output Code 5) at the maximum.
For maximum relay life with inductive load, external protection is recommended.

Alarm Trip Operation Terminal No. in parentheses

• Example Quad N.O. contacts (LL, L, H, HH)

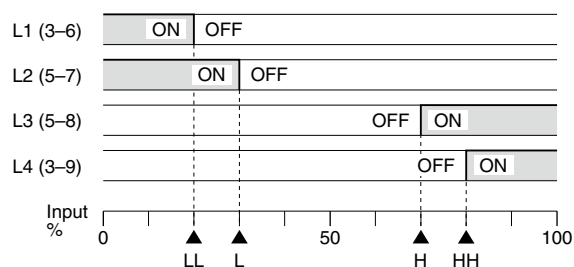

Trip operation in power failure

Output code 2: All relays turn OFF.

Output code 3: All relays turn ON.

Output code 5: Terminals 3 – 9, 5 – 8 turn ON.

MAINTENANCE

Regular calibration procedure is explained below:

■ CALIBRATION

Warm up the unit for at least 10 minutes.

• H (HH) Setpoint

Increase the input signal from a value lower than the setpoint and check that the relay trips at the setting value.

• L (LL) Setpoint

Decrease the input signal from a value higher than the setpoint and check that the relay trips at the setting value.

• Input Value

Apply 0%, 25%, 50%, 75% and 100% input signal. Perform input fine adjustment when input value is out of accuracy on the display.

Refer to this manual, when adjusting with front buttons. Refer to the M2EACFG users manual (EM-5151), when adjusting with M2EA Configurator Software (model: M2EACFG). And then follow the procedure shown below.

• INPUT FINE ADJUSTMENT

- 1) Set the input signal to 0%, and adjust the input display to 0% by [80] Input Zero fine adjust.
- 2) Set the input signal to 100%, and adjust the input display to 100% by [81] Input Span fine adjust.
- 3) Again set the simulated input to 0%, confirm the input display.
- 4) If input display is shifted, repeat the procedure from 1) to 3).

LIGHTNING SURGE PROTECTION

We offer a series of lightning surge protector for protection against induced lightning surges. Please contact us to choose appropriate models.