

Super-mini Signal Conditioners Mini-M Series

RTD TRANSMITTER

(PC programmable)

Functions & Features

- Accepts direct input from an RTD and provides a standard process signal
- PC programmable
- User's temperature table can be used
- Leadwire resistance compensation

Typical Applications

- Long distance transmission between the RTD and the transmitter
- Combination with intrinsic safety barriers

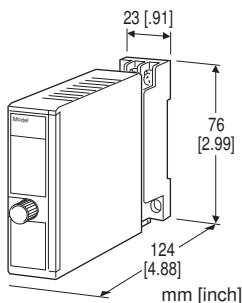

Note: Consult M-System for 2-wire RTD

(Configurator software is used to change input type and temperature range.)

[2] OUTPUT

Current

Z1: Range 0 – 20 mA DC

Voltage

V1: Range -2.5 – +2.5 V DC

V2: Range -10 – +10 V DC

(Configurator software is used to change output over the described range of the selected suffix code. For changing out of this range, set the Output Range Selectors inside the unit before software adjustment.)

[3] POWER INPUT

AC Power

M2: 100 – 240 V AC (Operational voltage range 85 – 264 V, 47 – 66 Hz)

(90 – 264 V for UL)

DC Power

R: 24 V DC

(Operational voltage range 24 V ±10 %, ripple 10 %p-p max.)

P: 110 V DC

(Operational voltage range 85 – 150 V, ripple 10 %p-p max.)

(110 V ±10 % for UL)

MODEL: M2XR2-[1][2]-[3][4]

ORDERING INFORMATION

- Code number: M2XR2-[1][2]-[3][4]

Specify a code from below for each of [1] through [4].

(e.g. M2XR2-4Z1-R/BL/CE/Q)

Input Code 4: Pt 100 (JIS '97, IEC) setting will be used if the input code is not specified.

- Temperature range (e.g. 0 – 500°C)
- Output range (e.g. 4 – 20 mA DC)
- Specify the specification for option code /Q (e.g. /C01/S01)

[1] INPUT RTD (2- or 3-wire)

- 1: JPt 100 (JIS'89)
- 3: Pt 100 (JIS'89)
- 4: Pt 100 (JIS'97, IEC)
- 5: Pt 50 Ω (JIS'81)
- 6: Ni 508.4 Ω
- 7: Pt 1000
- 8: Ni 100
- 9: Cu 10 @25°C
- 0: Specify (Please provide a resistance table.)

[4] OPTIONS (multiple selections)

Burnout

blank: Upscale burnout

/BL: Downscale burnout

(UL not available)

/BN: No burnout

(UL not available)

Standards & Approvals (must be specified)

/N: Without CE or UL

/CE: CE marking

/UL: UL approval, CE marking

Other Options

blank: none

/Q: Option other than the above (specify the specification)

SPECIFICATIONS OF OPTION: Q (multiple selections)

COATING (For the detail, refer to M-System's web site.)

/C01: Silicone coating

/C02: Polyurethane coating

/C03: Rubber coating (UL not available)

/C04: Polyolefin coating (UL not available)

TERMINAL SCREW MATERIAL

/S01: Stainless steel (UL not available)

RELATED PRODUCTS

- PC configurator software (model: JXCON)
Downloadable at M-System's web site.
A dedicated cable is required to connect the module to the PC. Please refer to the internet software download site or the users manual for the PC configurator for applicable cable types.

GENERAL SPECIFICATIONS

Construction: Plug-in
Connection: M3 screw terminals (torque 0.8 N·m)
Screw terminal: Chromated steel (standard) or stainless steel
Housing material: Flame-resistant resin (black)
Isolation: Input to output to power
Overrange output: Approx. -15 to +115 %
Manual zero adjustments: -5 to +5 %
(factory setting: 0 %)
Manual span adjustments: 95 to 105 %
(factory setting: 100 %)
Programming: Downloaded from PC; input type and range, output range, zero and span, simulating output, etc.
Burnout: Upscale standard; downscale or no burnout optional by programming
Linearization: Standard
Status indicator LED: Blinking patterns indicate different operating status of the transmitter.
Configurator connection: 2.5 dia. miniature jack; RS-232-C level

INPUT SPECIFICATIONS

Maximum leadwire resistance: 20 Ω per wire (3-wire)
Sensing current: ≤ 1.0 mA
Temperature range: See Table 1.

If not specified, the input range is shown below.

- 1: JPt 100 (JIS '89) 0 - 100°C
- 3: Pt 100 (JIS '89) 0 - 100°C
- 4: Pt 100 (JIS '97, IEC) 0 - 100°C
- 5: Pt 50 Ω (JIS '81) 0 - 200°C
- 6: Ni 508.4 Ω 0 - 100°C
- 7: Pt 1000 0 - 100°C
- 8: Ni 100 0 - 100°C
- 9: Cu 10 @25°C 0 - 100°C

OUTPUT SPECIFICATIONS

■ **DC Current**
Operational range: 0 - 24 mA DC
Output range: 0 - 20 mA DC
Minimum span: 1 mA
Offset: Lower range can be any specific value within the

output range provided that the minimum span is maintained.

Load resistance: Output drive 15 V max.
(e.g. 4 - 20 mA: 750 Ω [15 V ÷ 20 mA])
If not specified, the output range is 4 - 20 mA DC.

■ DC Voltage

Code V1 (narrow spans)
Operational range: -3 - +3 V DC
Output range: -2.5 - +2.5 V DC

Minimum span: 250 mV
Code V2 (wide spans)
Operational range: -11.5 - +11.5 V DC
Output range: -10 - +10 V DC

Minimum span: 1 V
Offset: Lower range can be any specific value within the output range provided that the minimum span is maintained.

Load resistance: Output drive 1 mA max.
(e.g. 1 - 5 V: 5000 Ω [5 V ÷ 1 mA])
If not specified, the output range is shown below.
V1: 0 - 1 V DC
V2: 1 - 5 V DC

INSTALLATION

Power Consumption

• **AC:**
Approx. 3 VA at 100 V
Approx. 4 VA at 200 V
Approx. 5 VA at 264 V
• **DC:** Approx. 2 W
Operating temperature: -30 to +60°C (-22 to +140°F)
Operating humidity: 30 to 90 %RH (non-condensing)
Mounting: Surface or DIN rail
Weight: 120 g (0.26 lb)

PERFORMANCE

Accuracy: Table 1 value or ±0.1 % of span, whichever is greater. Add 0.2 % when the output span equals 1/10 or narrower of the max. span.
Temp. coefficient: ±0.015 %/°C (±0.008 %/°F) of max. span at -5 to +55°C [23 to 131°F]
Response time: ≤ 0.9 sec. (0 - 90 %)
Burnout response: ≤ 10 sec.
Line voltage effect: ±0.1 % over voltage range
Insulation resistance: ≥ 100 MΩ with 500 V DC
Dielectric strength: 2000 V AC @1 minute (input to output to power to ground)

CALCULATION EXAMPLES OF OVERALL ACCURACY

[Example 1]
Input: Pt 100 (JIS '97, IEC), 0 - 500°C

Output: 4 – 20 mA DC

1) $\pm 0.15^\circ\text{C}$ referred from Table 1, is converted into % by the following equation: $0.15^\circ\text{C} \div 500^\circ\text{C} = 0.03\%$.

2) $0.03\% \leq 0.1\%$ of span. \Rightarrow 0.1% is selected.

3) Output span 16 mA (= 20 mA – 4 mA)

Max. span 20 mA

Output span $\geq 1/10$ of max. span \Rightarrow No need of adding 0.2%.

4) Overall accuracy equals $\pm 0.1\%$ of span

[Example 2]

Input: Pt 100 (JIS '97, IEC), 0 – 100°C

Output: 2.0 – 2.5 V DC

1) $\pm 0.15^\circ\text{C}$ referred from Table 1, is converted into % by the following equation: $0.15^\circ\text{C} \div 100^\circ\text{C} = 0.15\%$.

2) $0.15\% \geq 0.1\%$ of span. \Rightarrow 0.15% is selected.

3) Output span 0.5 V (= 2.5 V – 2.0 V)

Max. span 5 V

Output span $\leq 1/10$ of max. span \Rightarrow Add 0.2%.

4) Overall accuracy equals $\pm 0.35\%$ of span (0.15 + 0.2)

Table 1.

RTD		MIN. SPAN	USABLE RANGE	ACCURACY
JPt 100 (JIS'89)	°C	20	-200 to +500	± 0.15
	°F	36	-328 to +932	± 0.27
Pt 100 (JIS'89)	°C	20	-200 to +850	± 0.15
	°F	36	-328 to +1562	± 0.27
Pt 100 (JIS'97, IEC)	°C	20	-200 to +850	± 0.15
	°F	36	-328 to +1562	± 0.27
Pt 50Ω (JIS'81)	°C	20	-200 to +649	± 0.15
	°F	36	-328 to +1200	± 0.27
Ni 508.4Ω	°C	20	-50 to +200	± 0.15
	°F	36	-58 to +392	± 0.27
Pt 1000	°C	20	-200 to +200	± 0.15
	°F	36	-328 to +392	± 0.27
Ni 100	°C	20	-50 to +200	± 0.15
	°F	36	-58 to +392	± 0.27
Cu 10 @25°C	°C	20	-50 to +200	± 0.50
	°F	36	-58 to +392	± 0.90

STANDARDS & APPROVALS

EU conformity:

EMC Directive

EMI EN 61000-6-4

EMS EN 61000-6-2

Low Voltage Directive

EN 61010-1

Installation Category II

Pollution Degree 2

Input or output to power: Reinforced insulation (300 V)

Input to output: Basic insulation (300 V)

RoHS Directive

Approval:

UL/C-UL nonincendive Class I, Division 2,

Groups A, B, C, and D

EXTERNAL VIEW

FRONT VIEW (with cover open)

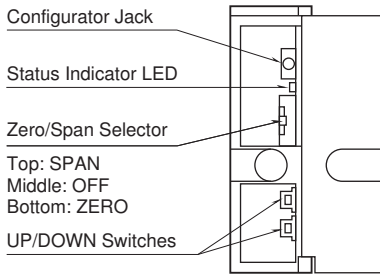

LEFT SIDE VIEW (with cover removed)

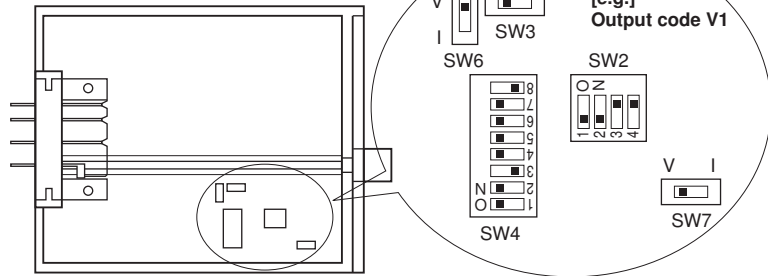

Output Range Selectors

The front cover cannot be turned open by 180 deg. when there is no extra space between units.

Refer to the instruction manual for detailed procedures.

EXTERNAL DIMENSIONS & TERMINAL ASSIGNMENTS unit: mm [inch]

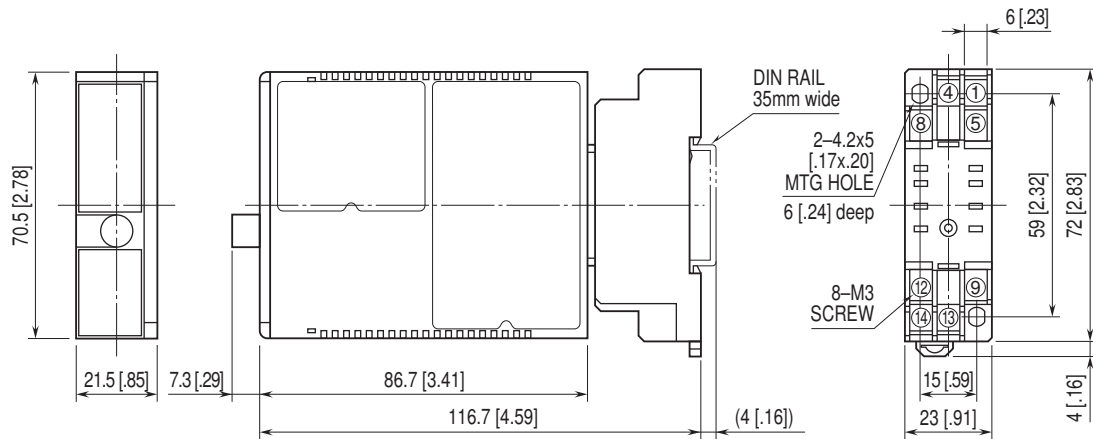

• When mounting, no extra space is needed between units.

SCHEMATIC CIRCUITRY & CONNECTION DIAGRAM

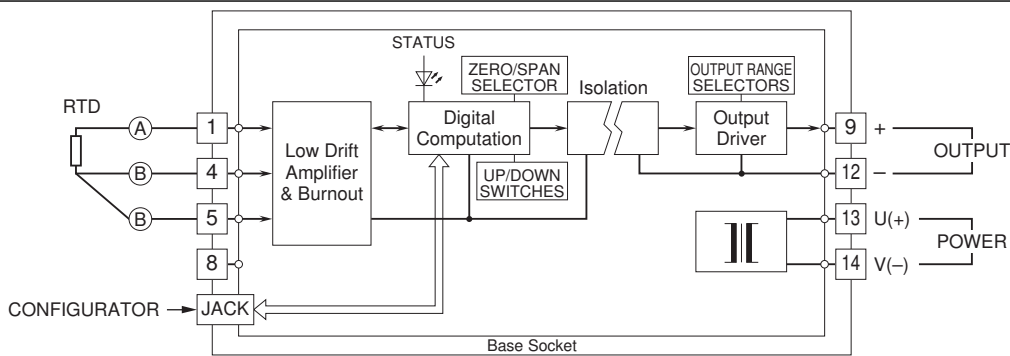

Specifications are subject to change without notice.