

Super-mini Signal Conditioners with Display Mini-M M2E Series

SELF-SYNCH TRANSMITTER

(PC programmable)

Functions & Features

- Converts position signals from a self-synchronizing motor into a DC signal proportional to the rotating shaft position
- Linearization
- 0 % and 100 % output range can be easily selected with the front buttons
- Field selectable output range
- OEL display with good visibility

Typical Applications

- Position indicator using self-synch
- Tank gauge
- Sounding level meter

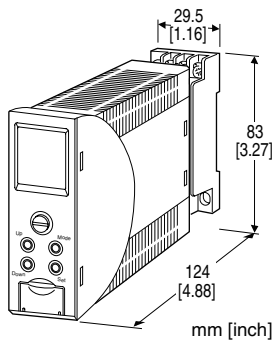

MODEL: M2EXS-[1][2]

ORDERING INFORMATION

- Code number: M2EXS-[1][2]

Specify a code from below for each of [1] and [2].

- (e.g. M2EXS-K3/Q)
- Specify the specification for option code /Q (e.g./C01/S01/SET)

INPUT

Self-synch signal

OUTPUT - Field-selectable

◆ DC Output

- Current output: 0 - 20 mA DC
- Voltage output: -5 - +5 V DC
- Voltage output: -10 - +10 V DC

[1] POWER INPUT

AC Power

K3: 100 - 120V AC

(Operational voltage range 85 - 132 V, 47 - 66 Hz)

L3: 200 - 240V AC

(Operational voltage range 170 - 264 V, 47 - 66 Hz)

[2] OPTIONS

blank: none

/Q: With options (specify the specification)

SPECIFICATIONS OF OPTION: Q (multiple selections)

COATING (For the detail, refer to M-System's web site.)

/C01: Silicone coating

/C02: Polyurethane coating

/C03: Rubber coating

TERMINAL SCREW MATERIAL

/S01: Stainless steel

EX-FACTORY SETTING

/SET: Preset according to the Ordering Information Sheet

(No. ESU-5137)

RELATED PRODUCTS

- M2E configurator software (model: M2ECFG)

Downloadable at M-System's web site.

A dedicated cable is required to connect the module to the PC. Please refer to the internet software download site or the users manual (EM-5147) for the M2E configurator for applicable cable types.

GENERAL SPECIFICATIONS

Construction: Plug-in

Connection: M3 screw terminals (torque 0.8 N·m)

Screw terminal: Chromated steel (standard) or stainless steel

Housing material: Flame-resistant resin (gray)

Isolation: Input to output to power

Overrange output: Approx. -5 to +105 % (Not available for current output not greater than 0 mA)

Output zero fine adj. range: -5 to +5% (front button)

Output span fine adj. range: 95 to 105% (front button)

Output setting: DIP Switch on side panel (refer to the instruction manual)

Configuration: Program with front buttons or Via PC.

Programmable features include: Refer to the parameter list.

Configurator connection: 2.5 dia. miniature jack;

RS-232-C level

DISPLAY

Display functions: Displays and sets measured range, engineering unit
Display size: Approx. 15.6 × 20.8 mm (0.61" × 0.82")
Number of pixels: 68 × 95 (horizontal × vertical)
Character color: Yellow
Display life: Approx. 60000 hours
 (Expected time for the Display brightness to be reduced to 50 % when the Display is used continuously with brightness setting 2 in 25 °C)
Display type: OEL display
Display digit: Negative 5 digits, positive 6 digits (-99999 to 999999)
Decimal point position: Selectable

INPUT SPECIFICATIONS

Measurement range: 0 - 359.99°
Minimum span: 60°
Input resistance: 1 MΩ min.
Rated input voltage: 90 V AC

OUTPUT SPECIFICATIONS

■ **DC Current**
Output range: 0 - 20 mA DC
Conformance range: 0 - 21mA DC
Minimum span: 1 mA
Offset: Lower range can be any specific value within the output range provided that the minimum span is maintained.
Load resistance: Output drive 15 V max.
 (Not available to output less than 0 mA, output range may not be extended to -5 %)
 ■ **DC Voltage**
Output range: -5 - +5 V DC, -10 - +10 V DC
Conformance range: -5.5 - +5.5 V DC, -11 - +11 V DC
Minimum span: 250 mV, 1 V
Offset: Lower range can be any specific value within the output range provided that the minimum span is maintained.
Load resistance: Output drive 1 mA max.

INSTALLATION

Power Consumption
 • **AC:**
 ≤ 5 VA for 100 - 120 V
 ≤ 7 VA for 200 - 240 V
Operating temperature: -5 to +55°C (23 to 131°F)
Operating humidity: 10 to 85 %RH (non-condensing)
Mounting: Surface or DIN rail
Weight: Approx. 200 g (0.44 lb)

PERFORMANCE

Accuracy: Input accuracy + output accuracy
 See CALCULATION EXAMPLES OF OVERALL ACURACY.
 Inversely proportional to the span.
 • **Input accuracy**
 ±0.2 % of span or ±0.5°, whichever is greater.
Display accuracy:
 Input display: Input accuracy ±1 digit
 Output display: Input accuracy + output accuracy ±1 digit
 • **Output accuracy:** ±0.04 % of max. output range
Temp. coefficient: ±0.015 %/°C (±0.008 %/°F) of max. span
Input resolution: 6000 - 36000
Output resolution: Max. 16 bits
Response time: ≤ 0.5 sec. (0 - 90 %)
Line voltage effect: ±0.1 % over voltage range
Insulation resistance: ≥ 100 MΩ with 500 V DC
Dielectric strength: 2000 V AC @1 minute (input to output to power to ground)

CALCULATION EXAMPLES OF OVERALL ACCURACY

[Example] Input Span 60°, Output Range 0 - 20 mA, Output Setting 4 - 20 mA
 ■ **Overall accuracy**
 • Input Accuracy = Input (60°) × Input Accuracy (0.2 %) = 0.12°
 0.12° < 0.5° thus
 Input Accuracy = (0.5°) ÷ 60° × 100 = 0.83 %
 • Output Accuracy = Output Range Span (20 mA) ÷ Output Span Setting (16 mA) × 0.04 % = 0.05 %
 Overall Accuracy = 0.83 + 0.05 = ±0.88 %

STANDARDS & APPROVALS

EU conformity:
 EMC Directive
 EMI EN 61000-6-4
 EMS EN 61000-6-2
 Low Voltage Directive
 EN 61010-1
 Installation Category II
 Pollution Degree 2
 Input or output to power: Reinforced insulation (300 V)
 Input to output: Basic insulation (300 V)
 RoHS Directive

EXTERNAL VIEW

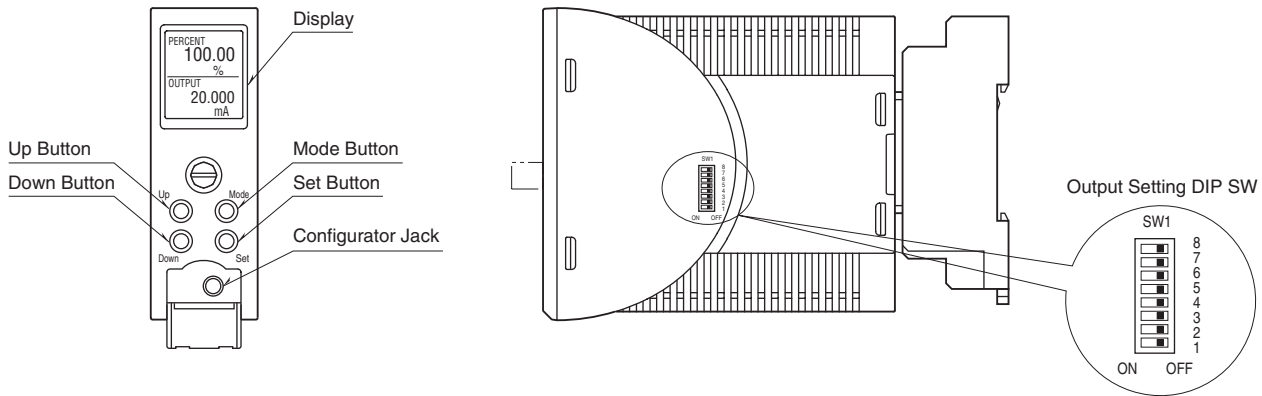

COMPONENT	FUNCTION
Display	Indicates present values, setting values and abnormal information. Two types of present values are displayed respectively at the upper and lower parts according to setting.
Mode Button	Shifts from Measuring mode to each setting mode. The destination changes depending on how long the button is held down. Pressing Mode button for ≥ 2 seconds returns to Measuring mode from each setting mode..
Set Button	Shifts the setting value of each setting parameter item to a setting changeable state. When at setting changeable state, used to move through the digits of setting value for input/output scaling and to enter (save) the setting value.
Up Button	Shifts through setting parameter items and to increase or select the setting value.
Down Button	Shifts through setting parameter items and to decrease or select the setting value.
Configurator Jack	Used to perform configuration with M2E configurator software (model: M2ECFG). When using the software, set the Lockout setting of the unit to 'Lock'.

Refer to the operating manual (EM-5137-B) for detailed procedures.

PARAMETER LIST

It is available to configure or confirm settings shown below by using front button. Configuring or confirming with PC is available when using M2E configurator software (model: M2ECFG).

MODE	ITEM	SETTING PARAMETER	RANGE	UNIT	INITIAL VALUE
Basic setting	01	Lockout setting	Lock / Unlock	—	Lock
	06	Angle offset	—	Deg.	0.00
	07	Angle span	60.00 – 359.99	Deg.	270.00
	10	Rotating direction	CW / CCW	—	CW
	14	0 % input scaling	-99999 – 999999	—	0.00
	15	100 % input scaling	-99999 – 999999	—	100.00
	16	Input decimal point	No decimal point The number of decimal places : 1 – 5	—	2 places of decimals
	17	Output range	0 – 20 mA -5 – +5 V -10 – +10 V	—	0 – 20 mA
	18	0 % output setting	0.000 – 19.000 -5.000 – 4.750 -10.000 – 9.000	mA V V	4.000
	19	100 % output setting	1.000 – 20.000 -4.750 – 5.000 -9.000 – 10.000	mA V V	20.000
	20	0 % output scaling	-99999 – 999999	—	0.00
	21	100 % output scaling	-99999 – 999999	—	100.00
	22	Output decimal point	No decimal point The number of decimal places : 1 – 5	—	2 places of decimals
	23	Overrange output < 0%	-5.00 – 0.00	%	-5.00
	24	Overrange output > 100%	100.00 – 105.00	%	105.00
	26	Loop test	-5.00 – 105.00	%	Cancel
Option	60	Unit (INP Scaling)	Choose from 68 types *	—	%
	61	Unit (OUT Scaling)	Choose from 68 types *	—	%
	67	Filter time constant	0 – 30	sec.	0
	71	Output Zero fine adjust	-5.000 – 5.000	%	0.000
	72	Output Span fine adjust	95.000 – 105.000	%	100.000
	01	Lockout setting	Lock / Unlock	—	Lock
Advanced	90	Display setting	Upper: choose from 5 types * Lower: choose from 6 types *	—	Upper: INPUT Lower: PERCENT
	91	Brightness	1 (darkest) – 4 (brightest)	—	4
	92	Display timeout	0 (always on), 1 – 60	min.	10
	93	Reset all settings	OFF / RESET	—	OFF
	94	Version indication	—	—	—
	01	Lockout setting	Lock / Unlock	—	Lock
Linearization	100	User's table linearization	Disable / Enable	—	Disable
	101	Number of points	2 – 32	—	2
	102 – 165	Table	-5.00 – 105.00	%	X001 -5.00 Y001 -5.00 X002 105.00 Y002 105.00
	01	Lockout setting	Lock / Unlock	—	Lock

* For detailed types, refer to the operating manual (EM-5137-B).

EXTERNAL DIMENSIONS & TERMINAL ASSIGNMENTS unit: mm [inch]

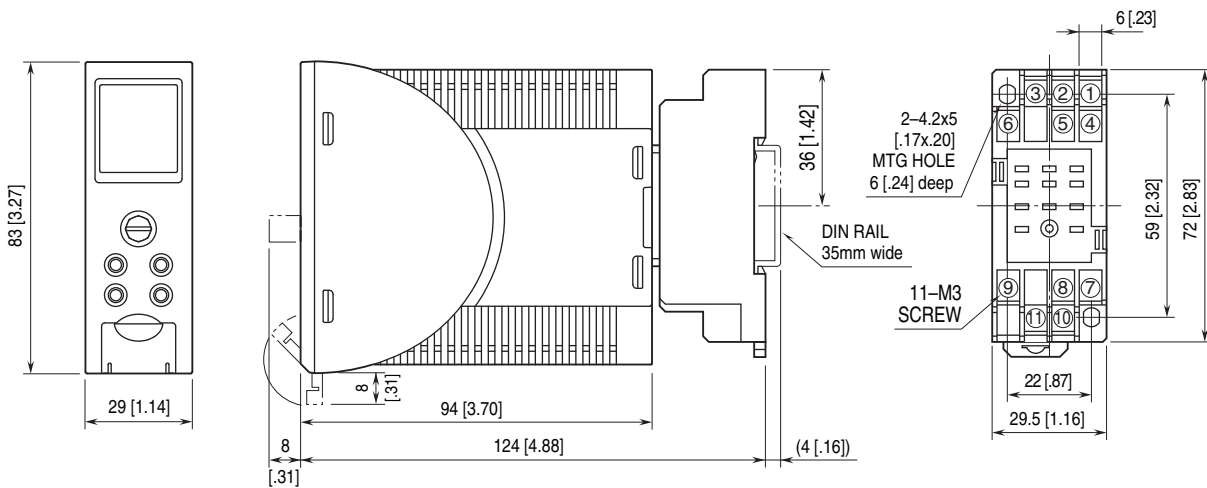

• When mounting, no extra space is needed between units.

SCHEMATIC CIRCUITRY & CONNECTION DIAGRAM

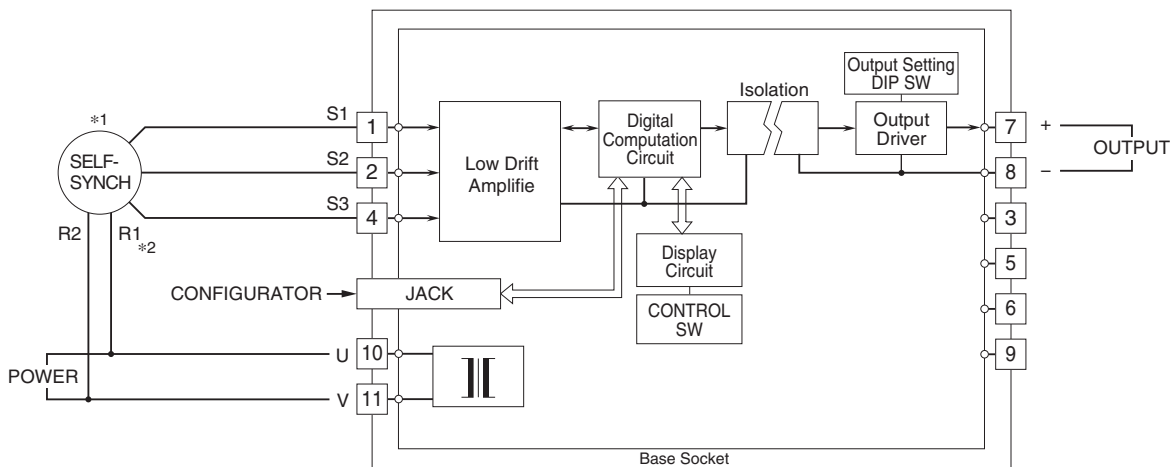

*1. The output increases when the self-synch rotates clockwise. For changing the operation to counterclockwise and increase, set the ITEM 10 'Rotating direction' to CCW.

*2. The power input of the unit has polarity. Be sure that the connection for R1 and R2 of the self-synch. When the connection is reversed, the signal conditioner output will be shifted by 180°.



Specifications are subject to change without notice.