

**BEFORE USE ....**

Thank you for choosing M-System. Before use, please check contents of the package you received as outlined below. If you have any problems or questions with the product, please contact M-System's Sales Office or representatives.

**■ PACKAGE INCLUDES:**

Lightning surge protector.....(1)

**■ MODEL NO.**

Confirm Model No. marking on the product to be exactly what you ordered.

**■ INSTALLATION / INSTRUCTION MANUAL**

This manual describes necessary points of caution when you use this product, including installation, and basic maintenance procedure.

**LIMITATION APPLICABLE TO M-RESTER**

The M-RESTER will protect electronics equipment from damage caused by lightning by absorbing most of the surge voltages.

However, M-RESTER may not be effective against certain extremely high voltages caused by a direct or almost direct hit by lightning.

M-RESTER must be installed according to this installation / instruction manual.

**GENERAL**

**■ FUNCTION & FEATURES**

- Specifically designed to protect 4 to 20mA DC signal line including both 4-wire and 2-wire transmitters from damage caused by lightning surges
- Absorbs surges only without affecting transmitted signals.

**■ SPECIFICATIONS**

	BETWEEN LINES		LINE TO GND
	MGD-24	MGD-65	
Discharge voltage	30V min.	70V min.	±500V max.
Max. surge voltage*	40V max.	80V max.	±650V max.
Leakage current	≤5μA @30V DC	≤5μA @70V DC	≤5μA @±140V DC
Max. line voltage	30V DC	70V DC	—
Response time	≤0.1 μsec.		
Discharge current	1000A (8 / 20 μsec.)		
Max. load current	100mA		
Internal series resist.	approx. 20Ω including return		

**POINTS OF CAUTION**

**■ ENVIRONMENT**

- When heavy dust or metal particles are present in the atmosphere, install M-RESTER inside proper housing and ventilate it.
- Do not install the M-RESTER where it is subjected to continuous vibration. Do not apply physical impact to the M-RESTER.
- Environmental temperature must be within -5 to +55°C (23 to 131°F) and relative humidity within 30 to 90% RH in order to ensure adequate life span and operation.

**■ DIELECTRIC STRENGTH TEST**

- DO NOT perform dielectric strength tests with wires connected to the unit. Otherwise the element will start discharging at discharge voltage, which can cause insulation failure. Be sure to return the wires after the test.

**■ AND ....**

- We recommend that you keep spare M-RESTERs so that you can replace them when necessary.
- Lightning surge can enter not only through signal lines but also through power supply lines. We recommend that you also use the Lightning Arrester for Power Lines for sufficient protection.

**COMPONENT IDENTIFICATION**

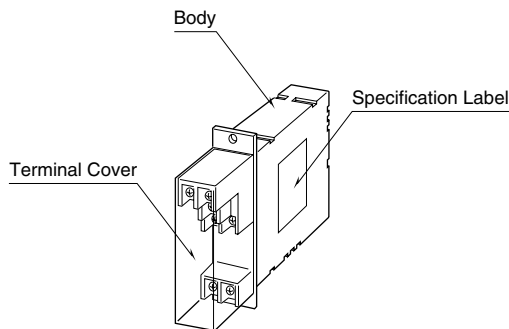

# INSTALLATION

Refer to the following drawings.

## EXTERNAL DIMENSIONS unit: mm [inch]

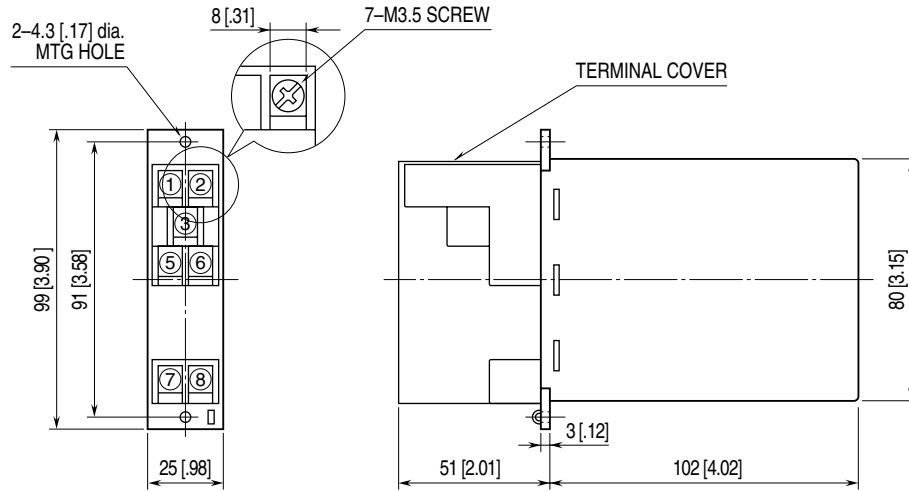

• When mounting, no extra space is needed between units.

## MOUNTING REQUIREMENTS mm (inch)

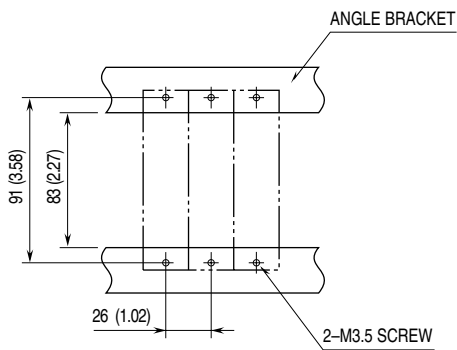

## TERMINAL CONNECTIONS

Connect the unit as in the diagram below.

Be sure to cross-wire between the Ground terminal (3) and metallic housing of the protected equipment. (100W max.)

Connection example with Ch.1 of MGD-24/65 and model MDP-24-1/65-1.

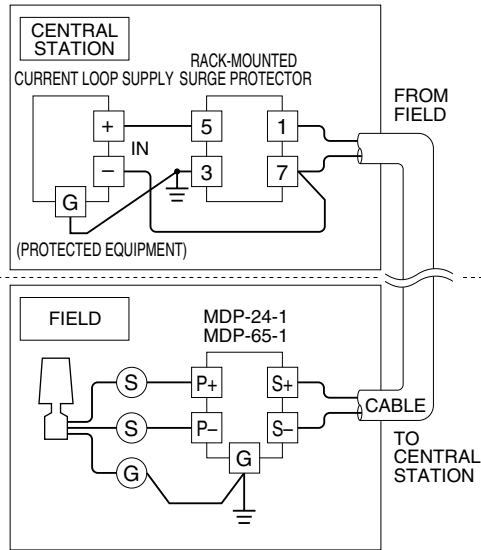

### ■ GROUNDING

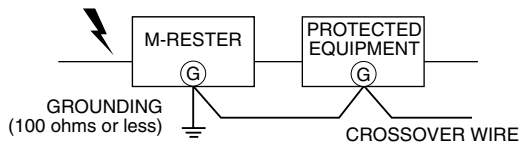

A crossover wire between M-RESTER ground and ground or metallic housing of equipment is required for protection.

If the protected equipment has no ground terminal, ground the M-RESTER only.

## MAINTENANCE

Check M-RESTER periodically. Many cases of lightning are ignored, and even lightning at a far distance often causes inductive surges. We recommend that you check your M-RESTER about twice a year, before and after the rainy season. Check whenever you experience a strong lightning occurrence.

Checking procedure is explained in the following:

### ■ CHECKING WIRING

- Make sure that wiring is done as instructed in the connection diagram.
- Make sure that the Ground terminal (3) is connected to the metallic housing of protected equipment.
- Make sure that the Ground terminal (3) is grounded to earth.

### DISCHARGE FUNCTION

Remove all the wires connected to the M-RESTER and test its discharge capability as follows:

- Apply 30V DC (MGD-24) or 70V DC (MGD-65) across the following terminals with a resistor of approx. 50k $\Omega$  in serial. Measure leakage current. ( $\leq 5\text{mA}$  standard)  
Then apply 40V DC (MGD-24) or 80V DC (MGD-65) and check that the discharging occurs. ( $\geq 100\text{mA}$  standard)  
If a DC source is not available, check resistance across these terminals on the high resistance range of multimeter, measured with positive potential at the terminal No.1 and 2 (infinite standard).  
Terminals (1+) – (7–), (2+) – (8–)
- Apply 140V DC across the following terminals with a resistor of approx. 1M $\Omega$  in serial. Measure leakage current. ( $\leq 5\text{mA}$  standard)  
Terminals (1) – (3), (2) – (3), (7) – (3), (8) – (3)  
If a DC source is not available, check resistance across these terminals on the high resistance range of multimeter (infinite standard).
- Check that discharging occurs across the same terminals with a 500V DC megger. (Indicator of the megger reaches over-scale.) Check also in the inverted polarity.
- If any of the above tests shows negative, replace the whole MRESTER unit.