

LIGHTNING SURGE PROTECTOR FOR STANDARD SIGNAL USE (fast response: 3 nsec.)	MODEL MDJST
---	--------------------

BEFORE USE

Thank you for choosing M-System. Before use, please check contents of the package you received as outlined below. If you have any problems or questions with the product, please contact M-System's Sales Office or representatives.

■ PACKAGE INCLUDES:

Lightning surge protector (body + base socket).....(1)

■ MODEL NO.

Confirm Model No. marking on the product to be exactly what you ordered.

■ INSTRUCTION MANUAL

This manual describes necessary points of caution when you use this product, including installation, connection and basic maintenance procedures.

LIMITATION APPLICABLE TO M-RESTER

The M-RESTER will protect electronics equipment from damage caused by lightning by absorbing most of the surge voltages.

However, M-RESTER may not be effective against certain extremely high voltages caused by a direct or almost direct hit by lightning.

M-RESTER must be installed according to this installation / instruction manual.

GENERAL

■ FUNCTION & FEATURES

- Designed specifically for 4 – 20mA DC and pulse signal line
- Battery-powered status indicator
- High discharge current capacity 20kA (8/20 μs)
- Shield terminal provided
- Compatible with IEC 61643-21 categories C1, C2, D1.

■ SPECIFICATIONS

See Table.

	NOMINAL VOLTAGE	MDJST-12x	MDJST-24x	MDJST-48x
Max. Continuous operating voltage (Uc)	Line to Line	±18V	±36V	±60V
	Line to Earth		±160V	
	SHLD to Earth		±160V	
Leakage current (initial value) @Uc	Line to Line		5μA max.	
	Line to Earth		5μA max.	
	SHLD to Earth		5μA max.	
Voltage protection level (Up) @4kV(1.2/50 μs)	Line to Line	±30V	±50V	±90V
	Line to Earth		±500V	
	SHLD to Earth		±600V	
Surge energy attenuation ratio	Line to Line		74 dB min.	
	Line to Earth		74 dB min.	
	SHLD to Earth		-	
Response Time (line to line)			3 nsec. max.	
Max. discharge current (Imax)			20kA (8/20 μs)	
Nominal current (IN)			1A	
Internal series resistance			3Ω max.	
AC durability			1 Arms (60 Hz 1s) 5 times	
Operational attenuation			3 dB max. @DC to 4 kHz, Zo = 600Ω (8 dB max. @100 kHz)	

POINTS OF CAUTION

■ ENVIRONMENT

- Indoor use. Install the unit with a status indicator on a place where the check button and monitor LED can be easily visible and accessible.
- When heavy dust or metal particles are present in the air, install the surge protector inside proper housing with sufficient ventilation.
- Do not install the surge protector where it is subjected to continuous vibration. Do not subject the unit to physical impact.
- Environmental temperature must be within -5 to $+55^{\circ}\text{C}$ (23 to 131°F) with relative humidity within 30 to 90% RH in order to ensure adequate life span and operation.
- Do not perform the installation, wiring or checking the M-RESTER during thunder storms.

■ WIRING

- Do not install cables close to noise sources (relay drive cable, high frequency line, etc.).
- Do not bind these cables together with those in which noises are present. Do not install them in the same duct.

■ DIELECTRIC STRENGTH TEST

- Unplug the body from the base socket before conducting a dielectric strength test. If the test is performed with the body, the surge protector will start discharging at the described discharge voltage, resulting as insulation failure. Be sure to plug the body back into the socket and secure it with the clamps after the testing is complete.

■ BATTERY LIFE

- The battery's life is assured for 10 years from the manufacturing year/month indicated to the specification marking (when the discharge element testing is used for ≤ 2 minutes/month).
- The battery continues to discharge even while it is unused. We recommend not keeping the MDJST in stock for a long period of time.
- Do not exchange or charge the battery.

■ AND...

- When the surge protector is detached from the socket, the signal line is disconnected and could affect to the system operations as the alarm etc. Consider this before detaching.
- We recommend that you keep spare surge protectors so that you can replace them when necessary.
- Lightning surge can enter not only through signal lines but also through power supply lines. We recommend that you also use the surge protectors for power line for sufficient protection.

COMPONENT IDENTIFICATION

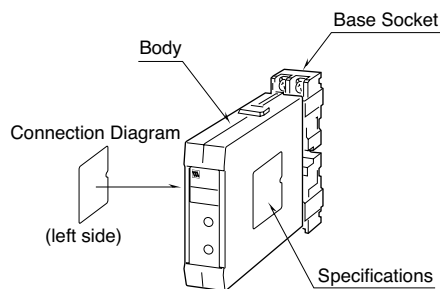

■ FRONT VIEW

■ For MDJST-xA1, MDJST-xA2

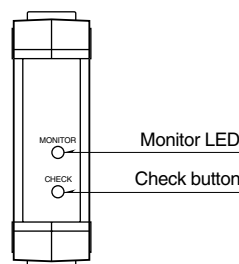

■ For MDJST-xY



INSTALLATION

Pull out the body in pressing the clamps located at the top and bottom of the unit to separate it from the base socket.

■ DIN RAIL MOUNTING

Set the base socket so that its DIN rail adaptor is at the bottom. Hung the upper hook at the rear side of base socket on the DIN rail and push in the lower. When removing the socket, push down the DIN rail adaptor utilizing a minus screwdriver and pull.

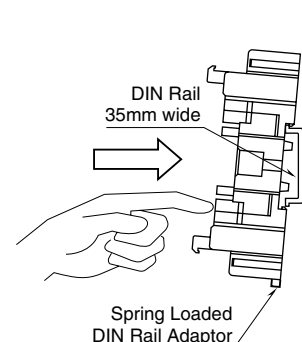

■ WALL MOUNTING

Refer to "EXTERNAL DIMENSIONS."

TERMINAL CONNECTIONS

Connect the unit as in the diagram below or refer to the connection diagram on the side of the unit.

Be sure to make cross-wiring as shown in "EARTHING." If the protected device is not provided with an earth terminal, ground only this unit's earth terminal.

EXTERNAL DIMENSIONS unit: mm (inch)

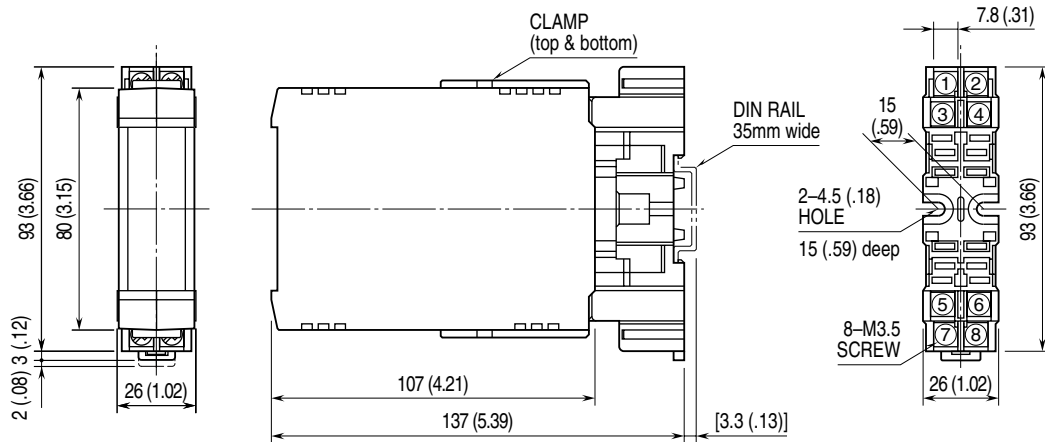

•When mounting, no extra space is needed between units.

CONNECTION DIAGRAM

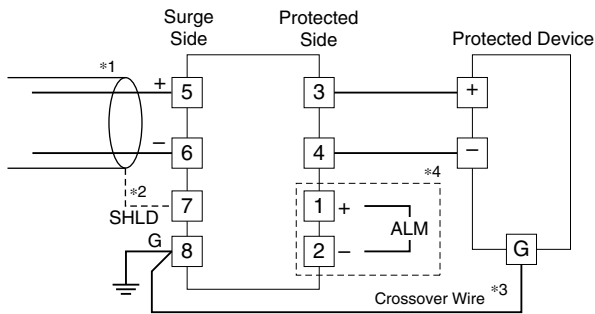

- *1. Do not connect a high capacity current source such as power supply. (The current source must be equipped with current limiter of 1A or less.)
- *2. For floating SHLD line, connect to the terminal (7).
- *3. The protected device's metal enclosure must be cross-wired to the earth terminal of the MDJST. If the protected device has no earth terminal, earth only the MDJST.
- *4. Sections enclosed in broken line are only applicable for "Status indicator" code "A2."

Alarm output connection example

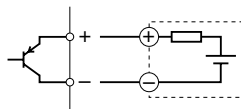

EARTHING

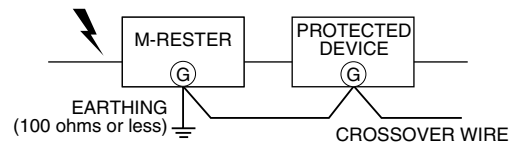

A crossover wire between M-RESTER earth and the earth or metallic housing of the equipment is required for protection. If the protected equipment has no earth terminal, earth the M-RESTER only.

STATUS INDICATOR

The status indicator options for degradation of the discharge element between lines are available. One of them indicates degradation by pushing Check Button. For another option, in addition to the above, an alarm output is available.

■ STATUS INDICATOR

- Monitor LED: Green, activated by Check button (momentary)
 - ON in normal operating
 - OFF in degradation of the voltage limiter or battery discharged
- Alarm output: Open Collector
 - 28V DC @100mA (resistive load)
 - OFF in normal conditions
 - ON in degradation of the voltage limiter or battery discharged

CHECKING

- Make sure that wiring is done as instructed in the connection diagram.
- Make sure that the earth terminal (8) is connected to the metallic housing of protected device.
- Make sure that the earth terminal (8) is connected to earth.

MAINTENANCE

Even lightning in remote locations could induce surges without our knowledge. Regular checking of the surge protector is important to find degradations in early stage, before and after the storm seasons, and whenever you experience a strong lightning storm.

Checking procedure is as explained below:

■ CHECK EXTERIOR

If discoloration or deformation is observed, replace with a new one immediately.

■ DISCHARGE ELEMENTS

Approximate checking can be conducted as following.

- MDJST-xAx (with the status indicator)

Confirm the state of the monitor LED pushing the check button. When it is off, it means that the unit is degraded or the battery is discharged. In this case, replace with a new one immediately. (With pulsating line signal or that containing ripples, the LED may flicker or blink when the voltage limiter is degraded.)
- MDJST-xAx (without the status indicator)

Remove all wiring connected to M-RESTER when you test the discharge elements.

 - 1) Check resistance across the following terminals on the high resistance range of multimeter and confirm no conduction. (The meter will show 10 MΩ or greater.)
Terminals (5) – (6), (5) – (8), (6) – (8) and (7) – (8)
 - 2) Check that discharging occurs across the same terminals with a 500V DC/1000 MΩ insulation tester. (The tester will show 20 MΩ or less.)
 - 3) If any of the above tests shows negative, replace the M-RESTER.