

**LIGHTNING SURGE PROTECTOR FOR
TWO-WIRE SIGNAL LOOP (ultra-slim; 2 channels)**

MODEL **MD72WD**

BEFORE USE

Thank you for choosing M-System. Before use, please check contents of the package you received as outlined below. If you have any problems or questions with the product, please contact M-System's Sales Office or representatives.

■ PACKAGE INCLUDES:

Surge protector.....(1)

■ MODEL NO.

Confirm Model No. marking on the product to be exactly what you ordered.

■ INSTRUCTION MANUAL

This manual describes necessary points of caution when you use this product, including installation, connection and basic maintenance procedures.

When using this product in potentially explosive atmosphere or hazardous (classified) location, you have to follow the safety procedure to install it. Please refer to "SAFE INSTALLATION MANUAL" for each type of certification.

LIMITATION APPLICABLE TO M-RESTER

The M-RESTER will protect electronics equipment from damage caused by lightning by absorbing most of the surge voltages.

However, M-RESTER may not be effective against certain extremely high voltages caused by a direct or almost direct hit by lightning.

M-RESTER must be installed according to this installation / instruction manual.

GENERAL

■ FUNCTION & FEATURES

- High discharge current capacity 20 kA (8 / 20 μs), 1 kA (10 / 350 μs)
- Ultra-thin 7-mm-wide module can be mounted in high density
- 2 channels packed in one housing
- Excellent protection employing multi-stage SPD circuits
- DIN rail mounting and grounding

■ SPECIFICATIONS

See Table 1.

POINTS OF CAUTION

■ ENVIRONMENT

- Indoor use.
- When heavy dust or metal particles are present in the air, install the unit inside proper housing with sufficient ventilation.
- Do not install the unit where it is subjected to continuous vibration. Do not subject the unit to physical impact.
- Environmental temperature must be within -25 to +85°C (-13 to +185°F) with relative humidity within 30 to 90% RH in order to ensure adequate life span and operation.
- This unit needs a DIN rail as earth grounding bar. Oxide film on the surface of an aluminium rail may lower the electric conductivity between this module and the ground. Use a steel or copper rail.

■ DIELECTRIC STRENGTH TESTING

- The surge protector starts discharging when several to several tens of volts is applied between lines and earth. Remove the grounding wire before conducting a test. Be sure to return the wire after the test.

■ AND

- We recommend that you keep spare surge protectors so that you can replace them when necessary.
- Lightning surge can enter not only through signal lines but also through power supply lines. We recommend that you also use the Lightning Surge Protector for Power Lines for adequate protection.

Table 1. Specifications

MODEL NO.		MD72WD-07	MD72WD-16	MD72WD-32
Max. continuous operating voltage (Uc)	Line to Line	±7V	±16V	±32V
	Line to Earth	±7V	±16V	±32V
Voltage protection level (Up) @6kV (1.2 / 50 μs)	Line to Line	30V	45V	70V
	Line to Earth	35V	50V	75V
Leakage current @Uc	Line to Line	≤10μA	≤5μA	
	Other sections	≤10μA	≤5μA	
Response time	Line to Line	≤4 nsec.		
	Other sections	≤4 nsec.		
Max. discharge current (Imax)	20kA (8 / 20 μs), 1.0kA (10 / 350 μs)			
Nominal current (In)	250mA			
Internal series resistance	4.7Ω ±20% per line			

COMPONENT IDENTIFICATION

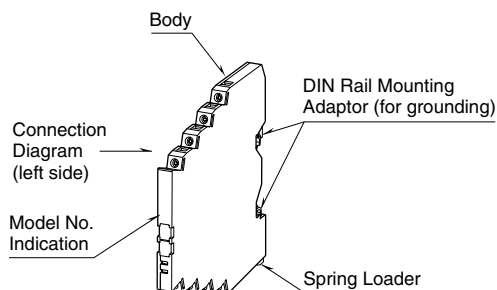

INSTALLATION

Mount the unit on a DIN rail. Once installed, do not move it to another DIN rail.

■ MOUNTING THE UNIT ON A DIN RAIL

- A) Hang the upper hook of the DIN rail mounting adaptor at the rear side of unit, on the DIN rail.
- B) Push in the lower in keeping pressing the unit to the DIN rail.
- C) DIN rails generally have slight individual variability in size. If you find it difficult to push in the lower part, go back to (A) and hang the upper part more deeply onto the rail and try (B) again.

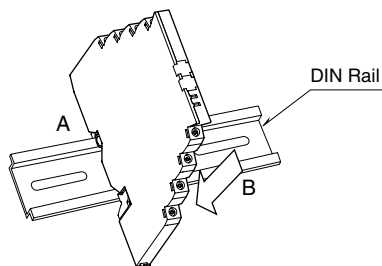

■ REMOVING THE UNIT

- A) Push down the spring loader utilizing a minus screwdriver.
- B) Confirm that it is pulled enough down and pull out the lower part of the unit.
- C) Detach the upper part from the DIN rail.

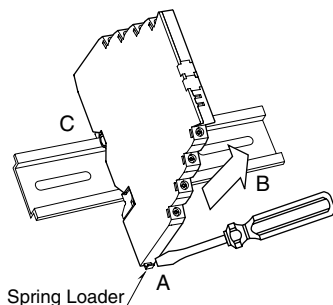

TERMINAL CONNECTION

Connect the unit as in the diagram below.

Be sure to ground the DIN rail on which the unit is mounted and cross-wire between the rail and FG terminal of the protected device as shown in Figure 1 in order to equalize the earth potential.

When the unit is connected with a device which has no FG terminal, ground the surge protector only.

EXTERNAL DIMENSIONS unit: mm (inch)

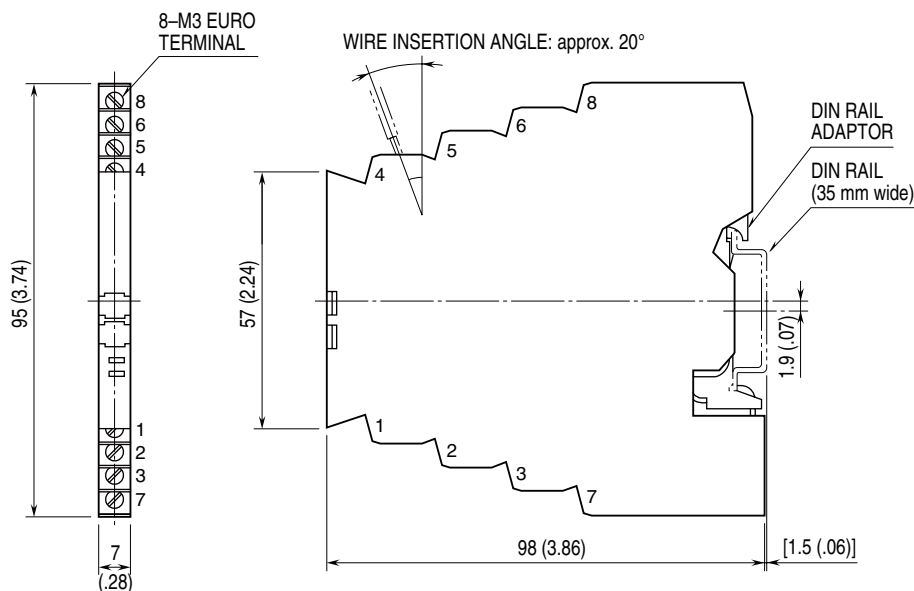
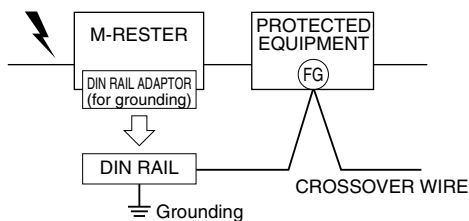

Figure 1. GROUNDING



Cross-wire from the DIN rail to the metal housing of the protected device to equalize the ground potential.

Ground only the surge protector when the protected device has no grounding terminal.

CAUTION WHEN WIRING

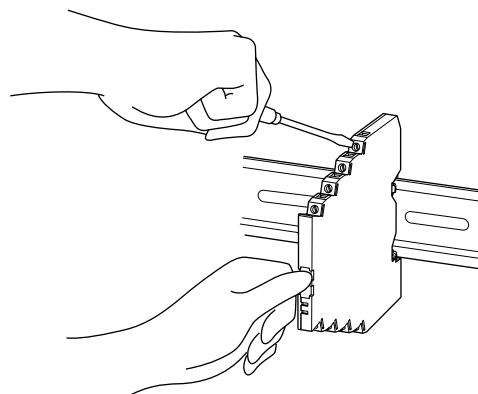

Hold the module steady at the front when you tighten/loosen screw terminals.

CONNECTION DIAGRAM

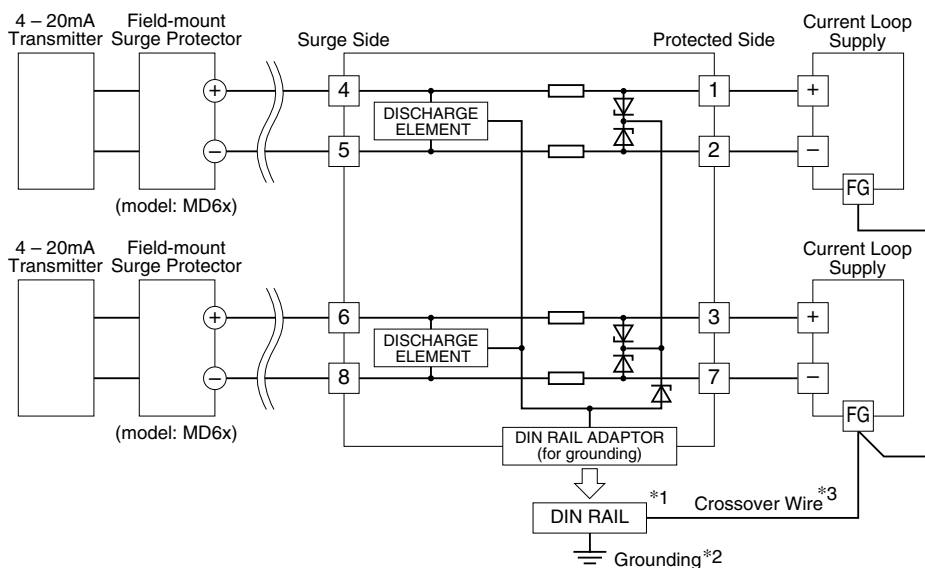

*1. Oxide film on the surface of an aluminium rail may lower the electric conductivity between this module and the ground. Use a steel or copper rail.

*2. Be sure to ground the DIN rail. Recommended grounding resistance $\leq 100\Omega$

*3. Cross-wire between the DIN rail or the terminal 7 and the metal housing of the protected device to equalize the earth potential. Ground only the surge protector when the protected device has no ground terminal.

WIRING INSTRUCTIONS

EURO TERMINAL

Torque: 0.3 N·m

Applicable wire size: 0.2 – 2.5 mm²

Stripped length: 8 mm

MAINTENANCE

Check surge protectors periodically. Many cases of lightning are ignored, and even lightning at a far distance often causes inductive surges.

We recommend that you check your surge protector about twice a year, before and after the rainy season. Check whenever you experience a strong lightning occurrence.

Checking procedure is explained in the following:

CHECKING WIRING

- 1) Make sure that wiring is done as instructed in the connection diagram.
- 2) Make sure that the DIN rail is connected to the metal enclosure of protected device.
- 3) Make sure that the surge protector is securely attached to the DIN rail, and that the rail is grounded to earth.

DISCHARGE ELEMENT

- 1) Remove all wiring connected to the surge protector when you test the module.
- 2) Check resistance across the following terminals on the high resistance range of multimeter and confirm no conduction.

Terminals (4+) – (5), (5+) – (4), (6+) – (8), (8+) – (6),
(4+) – (DIN rail), (6+) – (DIN rail)

Apply (+) terminal of the multimeter as indicated with each terminal number.

The tester should show 10 M Ω or greater.

- 3) Confirm conduction across the same terminals with a 500 V DC 1000 M Ω insulation tester. The tester should show 20 M Ω or less.

Polarity does not matter when connecting the insulation tester to the above terminals.

- 4) If any of the above tests shows negative, replace the surge protector.