

BEFORE USE

Thank you for choosing M-System. Before use, please check contents of the package you received as outlined below.

If you have any problems or questions with the product, please contact M-System's Sales Office or representatives.

■ PACKAGE INCLUDES:

Surge protector.....(1)

■ MODEL NO.

Check that the model No. described on the specifications matches the operational line voltage and other specifications as shown in 'PERFORMANCE' hereafter.

■ INSTALLATION / INSTRUCTION MANUAL

This manual describes necessary points of caution when you use this product, installation, and basic maintenance procedure.

LIMITATION APPLICABLE TO MATPH

The MATPH will protect electronics equipment from damage caused by induced lightning by absorbing most of the surge voltages.

However, MATPH may not be effective against certain extremely high voltages exceeding its discharge current capacity (20 kA @ 8/20 μ sec. waveform) caused by a direct or almost direct hit by lightning.

The MATPH must be installed according to this installation / instruction manual.

PERFORMANCE

Max. continuous operating voltage (Uc, Line to line):

750 V DC for MATPH-750

1000 V DC for MATPH-1000

Discharge voltage (Line to earth): 500 V DC

Voltage protection level (Up):

- MATPH-750

Line to line: 2.5 kV (@In)

Line to earth: 1.8 kV (@In)

- MATPH-1000

Line to line: 3.3 kV (@In)

Line to earth: 2.1 kV (@In)

Maximum discharge current (Imax): 20 kA (8/20 μ sec.)

Nominal discharge current (In): 10 kA (8/20 μ sec.)

Response time:

Line to line: \leq 4 nsec.

Line to earth: \leq 20 nsec.

Leakage current: \leq 1 mA

Insulation resistance: \geq 100 M Ω with 500 V DC (line to alarm output)

Dielectric strength: 2000 V AC @ 1 minute (line to alarm output)

POINTS OF CAUTION**■ CONFORMITY WITH EU DIRECTIVES**

- Altitude up to 2000 meters.
- The equipment must be installed such that appropriate clearance and creepage distances are maintained to conform to CE requirements. Failure to observe these requirements may invalidate the CE conformance.

■ INSTALLATION**• DANGER!**

DO NOT install the MATPH at the point common to an external lightning protection device such as a lightning rod. The MATPH will be subject to the danger of direct lightning.

• DANGER!

DO NOT perform an installation and wiring of the MATPH during thunder storms.

• Indoor use.

Be sure to house the MATPH inside an metal enclosure for safety. Even though the MATPH is capable of withstanding an induced discharge current expected in normal conditions, it is entirely possible to be hit by a certain strong lightning exceeding its designed capacity. It is also subject to a direct hit by a lightning. The MATPH will be destroyed by such high lightning energy.

We recommend to install the MATPH in a position where the monitor LED is clearly visible to facilitate inspection and maintenance.

DO NOT install the MATPH where it is subjected to continuous vibration. Do not apply physical impact to the MATPH.

Environmental temperature must be within -25 to +80°C (-13 to +176°F) and relative humidity within 30 to 90% RH in order to ensure adequate life span and operation.

■ HIGH TEMPERATURE**• DANGER!**

The front parts of the surface may be hot. DO NOT grab the sides of the module. When the MATPH's discharge element (zinc oxide element) gradually degrades, its increased leakage current causes high temperature at the surface of the MATPH, until the discharge element is finally separated from the power line by the thermal breaker. However, a part of the module may already be too hot to touch safely if the module is near the end of its life.

■ DIELECTRIC STRENGTH TESTING

Conduct the dielectric strength test with all power supply wires removed. The MATPH will start discharging at the described discharge voltage if a test voltage is applied with all power supply wires connected. It will result in an insulation failure.

■ AND....

We recommend that you keep spare MATPHs so that you can replace them quickly when necessary.

FEATURES

■ CURRENT CAPACITY

- The one-port SPD can be used regardless of the load current.

■ HIGH PERFORMANCE & RESPONSE TIME

- The discharge element (zinc oxide varistor) between the lines does not disturb the power line with follow current normally observed by a spark gap after a discharge. The response time is also very high.

■ HIGH DISCHARGE CURRENT CAPACITY

- The MATPH is designed to withstand 20 kA surges (test waveform 8/20 μ sec.). High design standard compared to normally induced surge current level of 1 kA.

■ THERMAL BREAKER

- The power supply voltage is continuously applied to the incorporated discharge element (zinc oxide element). Degraded element is automatically separated from the power lines for safety to prevent overheating caused by leakage current.
- The failure is notified visually by the monitor LED and remotely by an alarm contact.

■ PREVENTING ELECTRIC SHOCK

- The MATPH's terminal section with a terminal cover has IP20 protection level to protect from an electric shock.
- The MATPH is designed for use with ring shape solderless terminals for a wide range of wire sizes from 2 to 14 mm².

■ MEASUREMENT OF RESISTANCE TO EARTH

- A spark gap is employed as surge suppressor between line and earth. That makes measurement of resistance to earth without removing the SPD even in case switch gears connected. (If the measurement voltage is higher than 500 V DC, remove the SPD.)

SCHEMATIC CIRCUITRY

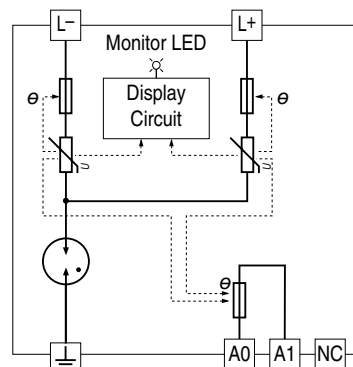

θ : Thermal breaker

Note: Terminals A0 & A1 are available for 'Alarm output' code 'A.'

INSTALLATION

■ DIN RAIL MOUNTING

The MATPH is mounted on a 35-mm-wide DIN rail. Set the MATPH so that its DIN rail adaptor is at the bottom. Position the upper hook at the rear side of base on the DIN rail and push in the lower.

When removing, push down the DIN rail adaptor utilizing a minus screwdriver and pull.

CONNECTION PROCEDURE

■ INSTALLING CIRCUIT BREAKERS

This unit incorporates a thermal breaker which separates the discharge element from the power line upon detecting the increased leakage current by the element's gradual degradation.

However, in rare cases, when the unit is hit by an extremely strong lightning which exceeds the unit's designed induced surge capacity, the discharge element may be burned out and short-circuited at a burst without the thermal breaker being able to separate it safely from the line.

Install a circuit breaker at the power source side of the surge protector as a backup protection. The example below shows a photovoltaic system. Molded-case circuit breakers (MCCB), residual current circuit breaker (RCCB) or current limiting fuses (slow-blow type only) can be used.

■ CONNECTION DIAGRAM

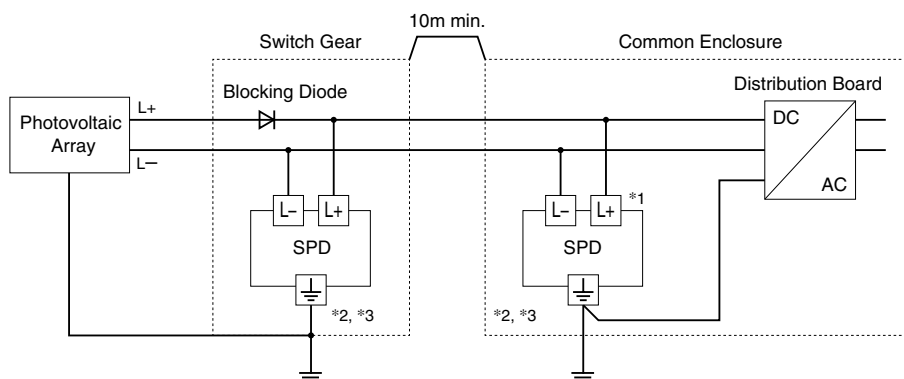

- *1. When the wiring distance is longer than 10 m between the power conditioner and the surge protector in the switch gear, install near the power conditioner.
- *2. Cable length between the branch point and the earthing: 0.5 m or less recommended
- *3. When the solar panel manufacturer requires earthing at negative line of DC side, do NOT use the earth terminal of the SPD but use the L- terminal. If also, earthing at positive line is necessary, earth the L+ terminal.

■ CIRCUIT BREAKER POSITION

If you want to use circuit breaker as SPD maintenance switch, insert a wiring MCCB for DC on SPD power side (diagram below).

Even when the output current of solar cell array is low, use 20 AT or more for wiring MCCB.

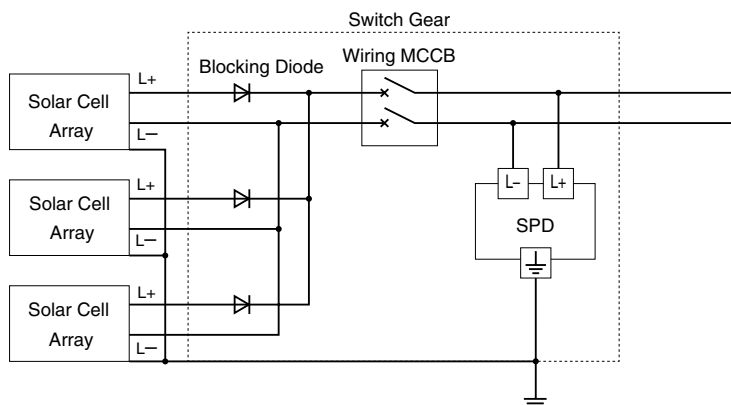

WIRING

LEADWIRES

Conductor cross-section area: 5.5 mm² minimum for both the power and the earth lines. However, a local industrial standard requirement for wiring should take precedence.

SOLDERLESS TERMINAL

Applicable ring tongue terminal without insulation sleeve is as indicated below. Spade tongue terminal must conform with the ring type size.

In order to ensure IP20 protection (IEC 60529) with a solderless terminal, cover the terminal with a insulation cap to prevent direct touching by a hand.

Applicable Solderless Terminal Size

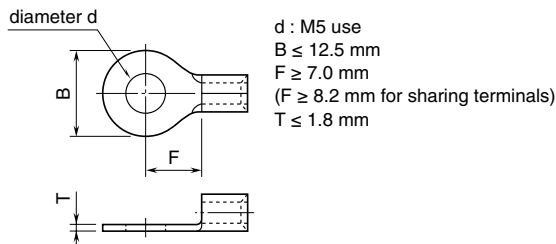

TORQUE

Tighten the screw terminals securely. Maximum allowable torque is of 2.5 N·m.

WIRE LENGTH

Keep the wire length to the minimum for both the power source side and the earth side. The wire length between the branch point and the earth should ideally be less than 0.5 meters. Extra long wires should not be bundled in coils, but be cut to the minimum required length.

EARTHING

COMMON EARTHING WITH CROSS-OVER WIRE

Basically a common earthing with cross-wiring between the MATPH and the protected device is recommended for adequate protection. Earthing resistance should be less than 100 ohms. If the protected device has no earth terminal, earth only the MATPH.

The earthing point should be close to the MATPH side as shown below.

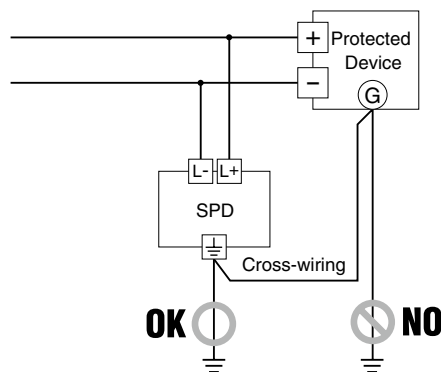

ALARM OUTPUT

Optional break-contact relay output is available to alert when the thermal breaker has separated the discharge element from the power supply circuit.

If the alarm output should be transmitted remotely via outdoor cables, a surge protector for signal line is required.

Choose a circuit breaker with an alarm output. Configure a logical addition sequence so that the alarm trips when both or either of the MATPH or the breaker alarm trips.

RELAY SPECIFICATIONS

Alarm output: The break-contact relay trips when the thermal breaker operates.

Rated load: 250V AC @50mA (resistive load)
 24V DC @50mA (resistive load)

CONNECTION

Terminal: Tension clamp
 Applicable wire size: 0.13 to 1.5 mm²
 Stripped length: 8 mm

CHECKING

WIRING

- Make sure that wiring is done as instructed in the connection diagram.
- Make sure that the earth terminal (G) is connected to the metallic housing of protected equipment.
- Make sure that the earth terminal (G) is earthed to earth.

MAINTENANCE

Even lightning in remote locations could induce surges without our knowledge. Regular checking of the surge protector is important to find degradations in early stage, before and after the storm seasons, and whenever you experience a strong lightning storm.

DO NOT attempt checking or replacing the surge protector during a thunder storm for safety.

Checking procedure is as explained below:

■ CHECK EXTERIOR

If discoloration or deformation is observed, replace with a new one immediately.

■ CHECK MONITOR LED

Green LED turns on during normal operation, indicating the surge protector is functioning properly. Turning off means that the protector is in failure. Replace with a new one immediately.

When the voltage between L+ and L- is low, the monitor LED may be dark. In that case, check the LED with an insulation tester (100 V DC to operational voltage). When the polarity is opposite, change it.

EXTERNAL DIMENSIONS & TERMINAL ASSIGNMENT

Unit: mm (inch)

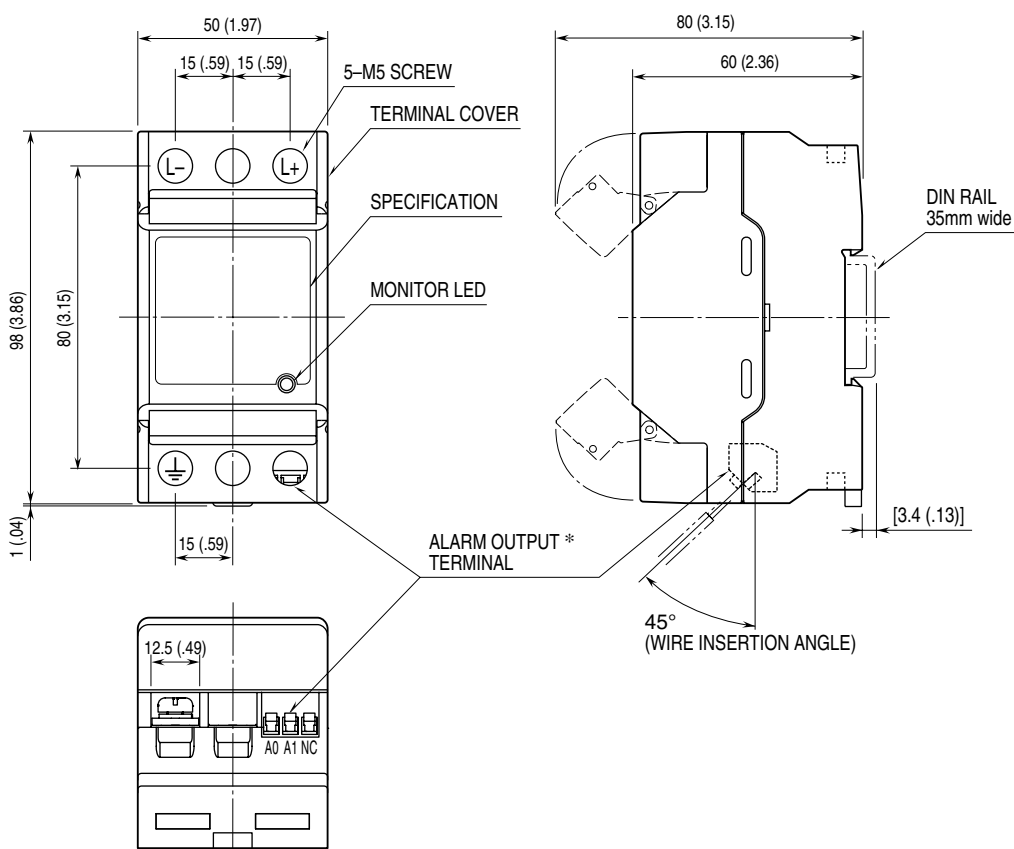

* Only for 'Alarm output' code 'A.'