

Lightning Surge Protectors for Electronics Equipment M-RESTER

LIGHTNING SURGE PROTECTOR FOR PULSE SIGNAL

(ultra-slim)

Functions & Features

- High discharge current capacity 20 kA (8 / 20 μ s), 1 kA (10 / 350 μ s)
- Ultra-thin 7-mm-wide module can be mounted in high density
- Excellent protection employing multi-stage SPD circuits
- DIN rail mounting and grounding
- Shield terminal provided
- Protects two pulse signal lines

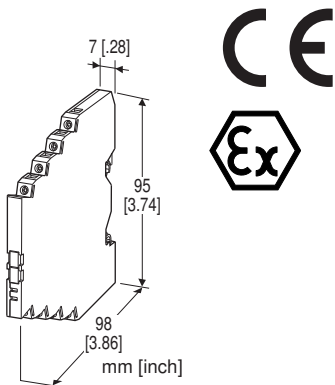

MODEL: MD7PL-[1][2][3][4]

ORDERING INFORMATION

- Code number: MD7PL-[1][2][3][4]

Specify a code from below for each of [1] through [4].

(e.g. MD7PL-PFF0/Q)

For the safety approval code 2, specify the product's destination country using Ordering Information Sheet (No. ESU-8057).

- Specify the specification for option code /Q
(e.g. /C01)

[1] COMMON

P: Positive (PNP)

N: Negative (NPN)

[2] SHIELD TERMINAL (line / earth)

FF: Floating / Floating

FG: Floating / Grounding

[3] SAFETY APPROVAL

0: None

2: ATEX intrinsic safety

[4] OPTIONS

blank: none

/Q: With options (specify the specification)
(ATEX intrinsic safety not available)

SPECIFICATIONS OF OPTION: Q

COATING (For the detail, refer to M-System's web site.)

/C01: Silicone coating

/C02: Polyurethane coating

GENERAL SPECIFICATIONS

Construction: Slim-sized front terminal structure

Degree of protection: IP20

Connection: Euro terminal block (torque 0.3 N·m)

Applicable wire size: 0.2 - 2.5 mm², stripped length 8 mm

Grounding: DIN Rail

Housing material: Flame-resistant resin (black)

INSTALLATION

Operating temperature: -25 to +85°C (-13 to +185°F)

(See Safety Parameters for use in a hazardous location.)

Operating humidity: 30 to 90 %RH (non-condensing)

Mounting: DIN Rail (TH35-7.5, 1-mm-thick)

Oxide film on the surface of an aluminium DIN rail may lower the electric conductivity between this module and the ground. Use a steel or copper rail.

Weight: 70 g (2.5 oz)

PERFORMANCE

MODEL NO.		MD7PL-PFF	MD7PL-PFG	MD7PL-NFF	MD7PL-NFG
Max. continuous operating voltage (Uc)	Line to Line	-30V		+30V	
	Line to Earth	±160V			
	Line to SHLD	±160V			
	SHLD to Earth	±160V	short	±160V	short
Voltage protection level (Up) @6kV (1.2 / 50 μs)	Line to Line	-50V		+50V	
	Line to Earth	±800V			
	Line to SHLD	±1200V	±800V	±1200V	±800V
	SHLD to Earth	±800V	short	±800V	short
Leakage current @Uc	Line to Line	≤ 5μA			
	Other sections	≤ 5μA			
Response time	Line to Line	≤ 4 nsec.			
	Other sections	≤ 20 nsec.			
Max. discharge current (Imax)	20kA (8 / 20 μs), 1.0kA (10 / 350 μs)				
Nominal current (In)	100mA				
Internal series resistance	11Ω ±10% per line				
Surge protection	IEC 61643-21 Categories C1, C2, D1				

STANDARDS & APPROVALS

EU conformity:

ATEX Directive

Ex ia EN 60079-11

EMC Directive

EMI EN 61000-6-4

EMS EN 61000-6-2

RoHS Directive

Safety approval:

ATEX: Intrinsic safety

⊕ II 1G, Ex ia IIC; T4 and T5 Ga

EN 60079-0

EN 60079-11

SAFETY PARAMETERS

■ ATEX IS DATA

Ui (Vmax)	32V		
Ii (Imax)	any		
Ci	10 nF		
Li	0 μH		
Pi	Temp. Class	Range	Parameter
	T4	-25 to +40°C	1.3W
		-25 to +60°C	1.2W
		-25 to +80°C	1.0W
T5	-25 to +40°C	1.0W	

CONNECTION EXAMPLES

■ CONNECTION DIAGRAM

• MD7PL-P

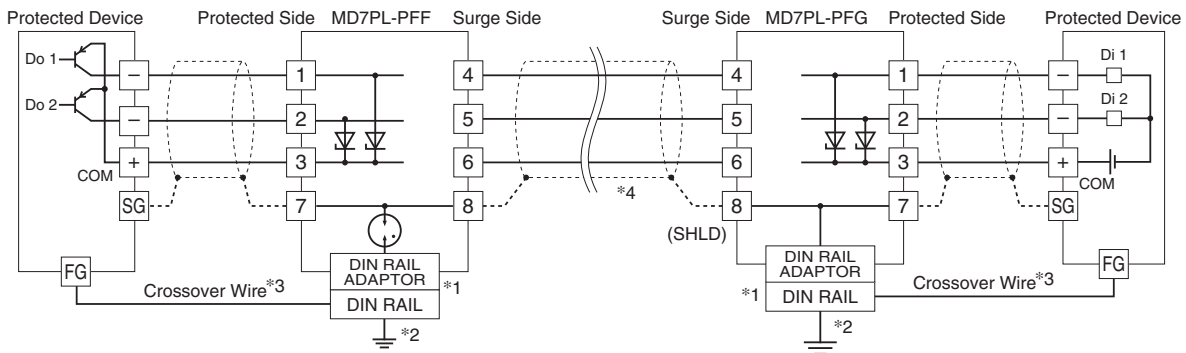

• MD7PL-N

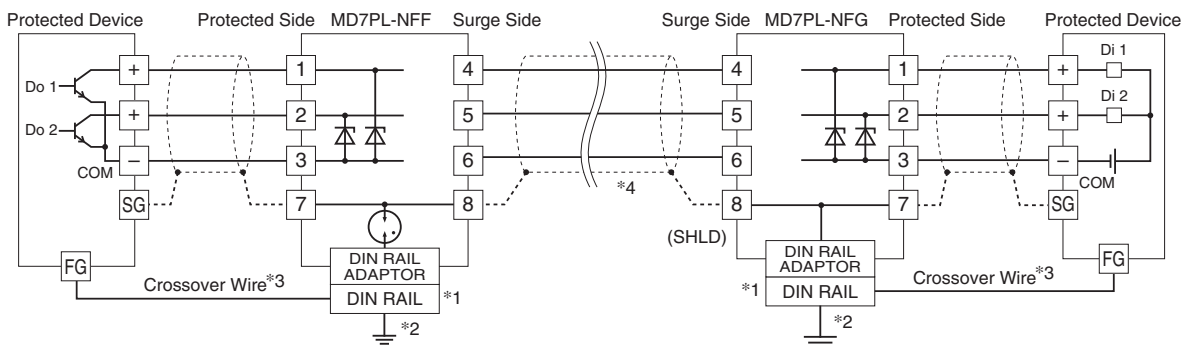

*1. Oxide film on the surface of an aluminium rail may lower the electric conductivity between this module and the ground.

Use a steel or copper rail.

*2. Be sure to ground the DIN rail. Recommended grounding resistance $\leq 100\Omega$

*3. Cross-wire between the DIN rail and the metal housing of the protected device to equalize the earth potential.

Ground only the surge protector when the protected device has no ground terminal.

*4. Shield wiring method is an example. Proceed according to the system requirements.

COM TERMINAL

- To protect more than three (3) signals with shared common line, it must be connected to the COM terminals of all MD7PL modules.
- Cross-wiring must be placed at the surge side of the MD7PL (terminal 6).
- Direct connection of the shared common line must be to the COM terminal of the MD7PL located closest to the grounding point.
- All MD7PL must be installed closely side by side on one DIN rail, so that the cross-wire be the shortest possible.

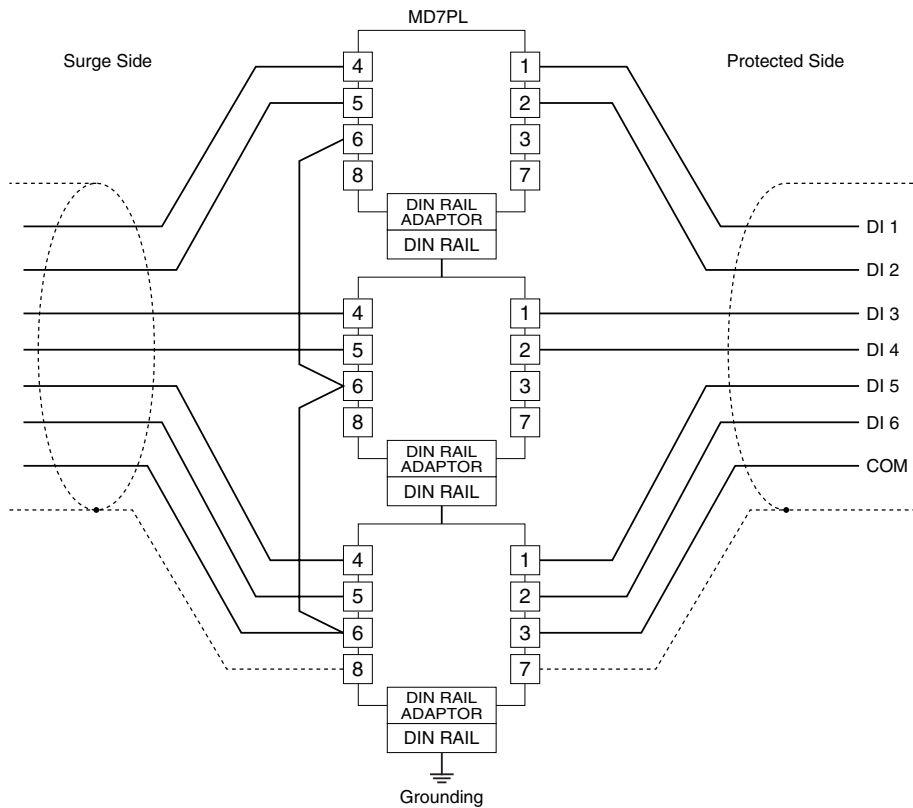

EXTERNAL DIMENSIONS & TERMINAL ASSIGNMENTS unit: mm [inch]

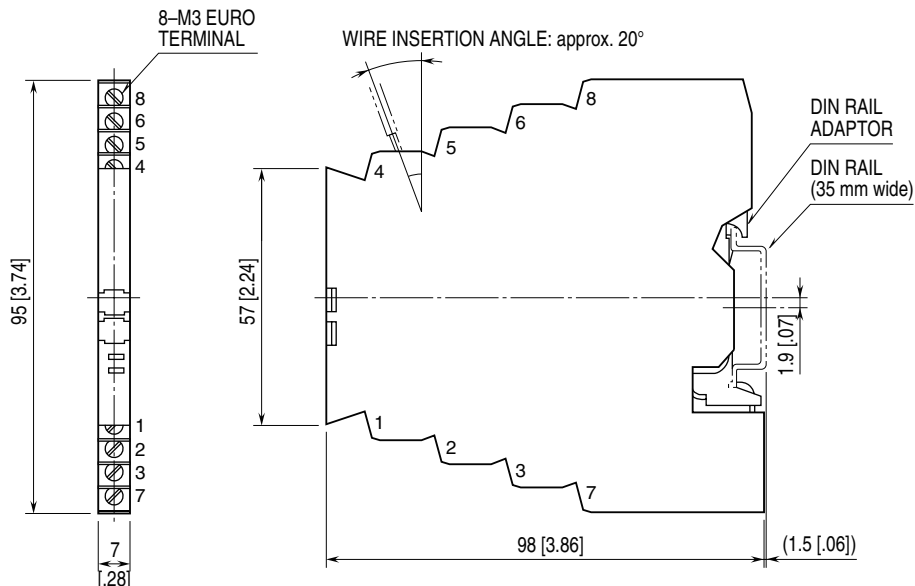

SCHEMATIC CIRCUITRY

SHIELD TERMINAL	MODEL NO.	SCHEMATIC CIRCUITRY	APPLICATIONS
<ul style="list-style-type: none"> • Common: Positive • Line to SHLD: Floating • Earth to SHLD: Floating 	<ul style="list-style-type: none"> • MD7PL-PFFx 		<ul style="list-style-type: none"> • PNP connection • To protect a device having isolation between Signal and Earth. • When SHLD should be floating against the earth. (single-end grounding)
<ul style="list-style-type: none"> • Common: Positive • Line to SHLD: Floating • Earth to SHLD: Grounding 	<ul style="list-style-type: none"> • MD7PL-PFGx 		<ul style="list-style-type: none"> • PNP connection • To protect a device having isolation between Signal and Earth. • When SHLD should be grounded. (single- or both-end grounding)
<ul style="list-style-type: none"> • Common: Negative • Line to SHLD: Floating • Earth to SHLD: Floating 	<ul style="list-style-type: none"> • MD7PL-NFFx 		<ul style="list-style-type: none"> • NPN connection • To protect a device having isolation between Signal and Earth. • When SHLD should be floating against the earth. (single-end grounding)
<ul style="list-style-type: none"> • Common: Negative • Line to SHLD: Floating • Earth to SHLD: Grounding 	<ul style="list-style-type: none"> • MD7PL-NFGx 		<ul style="list-style-type: none"> • NPN connection • To protect a device having isolation between Signal and Earth. • When SHLD should be grounded. (single- or both-end grounding)

Sections enclosed with broken line may differ depending upon the models.



Specifications are subject to change without notice.