

**MULTI M-RESTER**

MODEL **MDR-8**

**BEFORE USE ....**

Thank you for choosing M-System. Before use, check the package you received as below.

If you have any problems or questions on the product, please contact M-System's Sales Office or representatives.

■ **PACKAGE INCLUDES:**

Lightning surge protector..... (1)

■ **MODEL NO.**

Check that model No. described on specification label is exactly what you ordered.

■ **INSTALLATION / INSTRUCTION MANUAL**

This manual describes necessary points of caution when you use this product, installation, and basic maintenance procedure.

**LIMITATION APPLICABLE TO M-RESTER**

The M-Rester will protect electronics equipment from damage caused by lightning by absorbing most of the surge voltages.

However, M-Rester may not be effective against certain extremely high voltages caused by a direct or almost direct hit by lightning.

M-Rester must be installed according to this installation / instruction manual.

**GENERAL**

■ **FUNCTION & FEATURES**

- Designed specifically for ON-OFF signals, protecting semiconductor switches used for ON-OFF outputs from the computer or PLC from lightning surge damage that enters on the wiring between these instruments
- 8 channels
- Most convenient as junction board
- Minimum mounting space

■ **SPECIFICATIONS**

	BTWN LINES	LINE TO COM	LINE/COM TO G
Discharge voltage	±30V min.	30V min.	±60V min.
Max. surge voltage*	±40V max.	40V max.	±650V max.
Leakage current	≤5μA @±30V DC	≤5μA @30V DC	≤5μA @±60V DC
Response time	≤0.1 μsec.		
Discharge current	1000A (8 / 20 μsec.)		
Max. load current	100mA		
Int. series resistance	approx. 100Ω		

\*The maximum voltage that could pass through M-RESTER. Protected equipment must be able to withstand this voltage for a very short time period.

**POINTS OF CAUTION**

■ **ENVIRONMENT**

- Indoor Use
- When heavy dust or metal particles are present in the atmosphere, install M-RESTER inside proper housing and ventilate it.
- Do not install the M-RESTER where it is subjected to continuous vibration. Do not apply physical impact to the M-RESTER.
- Environmental temperature must be within -5 to +55°C (23 to 131°F) and relative humidity within 30 to 90% RH in order to ensure adequate life span and operation.

■ **DIELECTRIC STRENGTH TEST**

- DO NOT perform dielectric strength tests with wires connected to the unit. Otherwise the element will start discharging at discharge voltage, which can cause insulation failure. Be sure to return the wires after the test.

■ **AND ....**

- We recommend that you keep spare M-RESTERs so that you can replace them when necessary.
- Lightning surge can enter not only through signal lines but also through power supply lines. We recommend that you also use the Lightning Arrester for Power Lines for sufficient protection.

**COMPONENT IDENTIFICATION**

■ **REAR VIEW**

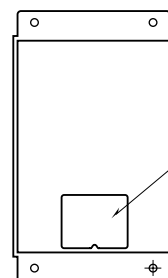
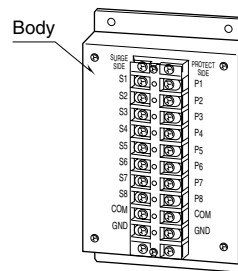

## INSTALLATION

Refer to the figure below.

### EXTERNAL DIMENSIONS mm (inch)

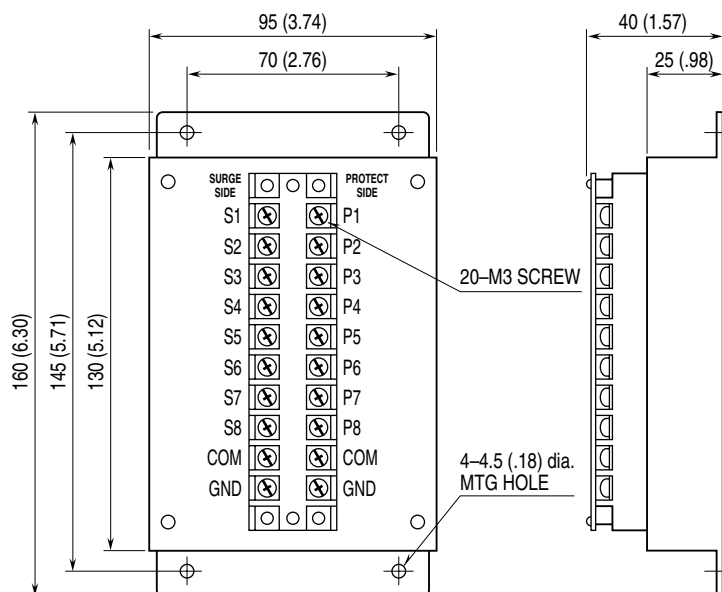

•When mounting, no extra space is needed between units.

## TERMINAL CONNECTIONS

Connect the unit as in the diagram below.

Be sure to cross-wire between the ground terminal (G) and that of the protected equipment.

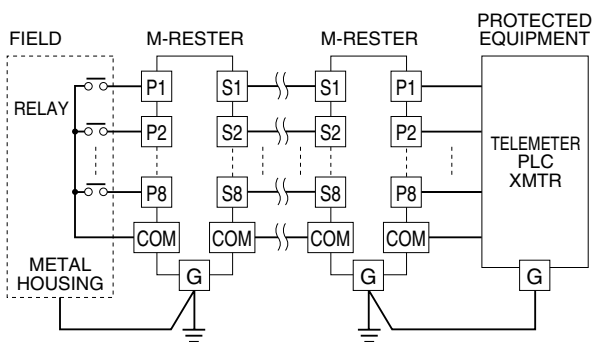

All negative lines are connected to COM.

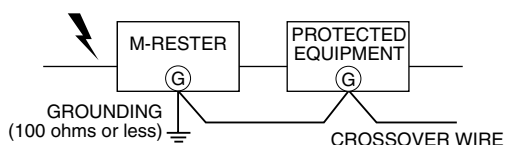

A crossover wire between M-RESTER ground and the ground or metallic housing of the equipment is required for protection. If the protected equipment has no ground terminal, ground the M-RESTER only.

## MAINTENANCE

Check M-RESTER periodically. Many cases of lightning are ignored, and even lightning at a far distance often causes inductive surges. We recommend that you check your M-RESTER about twice a year, before and after the rainy season. Check whenever you experience a strong lightning occurrence. Checking procedure is explained in the following:

### CHECKING WIRING

- Make sure that wiring is done as instructed in the connection diagram.
- Make sure that the ground terminal (G) is connected to the metallic housing of protected equipment.
- Make sure that the ground terminal (G) is grounded to earth.

### DISCHARGE ELEMENTS

Remove all wiring connected to M-RESTER when you test the discharge elements.

- Check resistance across the following terminals on the high resistance range of multimeter and confirm no conduction. (The meter will show 10MΩ or greater.) Terminals (P1) or (P2) or (P3) or (P4) or (P5) or (P6) or (P7) or (P8) – (COM), (COM) – (G) When measuring across the Px – COM, apply the positive voltage to the Px terminal.
- Check that discharging occurs across the same terminals with a 500V DC/1000MΩ megger. (The megger will show 20MΩ or less.)
- If any of the above tests shows negative, replace the M-RESTER