

**BEFORE USE ....**

Thank you for choosing M-System. Before use, please check contents of the package you received as outlined below. If you have any problems or questions with the product, please contact M-System's Sales Office or representatives.

**PACKAGE INCLUDES:**

- Surge protector.....(1)
  - DIN rail mounting adaptor\*.....(1)
  - Screws for DIN rail mounting (M4 × 8)\* .....(2)
- \*Included with option code /A33

**MODEL NO.**

Confirm Model No. marking on the product to be exactly what you ordered.

**INSTRUCTION MANUAL**

This manual describes necessary points of caution when you use this product, including installation, connection and basic maintenance procedures.

**LIMITATION APPLICABLE TO M-RESTER**

The M-RESTER will protect electronics equipment from damage caused by lightning by absorbing most of the surge voltages.

However, M-RESTER may not be effective against certain extremely high voltages caused by a direct or almost direct hit by lightning.

M-RESTER must be installed according to this installation / instruction manual.

**CAUTION (DISCHARGE CAPACITY)**

The discharge capacity of this unit has been increased to 5000 Amps. However, using an older style base socket with any upgraded head element could decrease the overall effectiveness of the unit.

The upgraded version element and socket are distinguished by blue labels affixed to them. If you are replacing the head element only, be sure to check the label color of the base socket that is already installed.

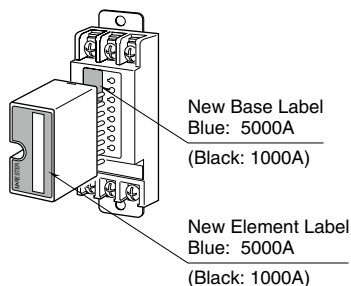

**SPECIFICATIONS**

	LINE TO LINE		LINE TO EARTH
	B - C	B or C - A	
Max. continuous operating voltage (Uc)	±6V	±3V	±140V
Voltage protection level (Up)@1kV (100A)	±32V	±16V	±650V
	2 - 3	2 or 3 - 1	
Voltage protection level (Up)@2kV (1kA)	±40V	±25V	±800V
	2 - 3	2 or 3 - 1	
Leakage current	≤ 2µA @±6V DC B - C	≤ 2µA @±3V DC B or C - A	≤ 2µA @±140V DC
Capacitance @1 MHz	≤ 1000 pF		≤ 100 pF
Response time	≤ 0.1 microseconds		
Max. discharge current (Imax)	5000A (8 / 20 µs)		
Nominal current (IN)	100mA		
Internal series resistance	10 Ω ±0.1%, 30 ppm/°C (17 ppm/°F)		

**POINTS OF CAUTION**

**CONFORMITY WITH EU DIRECTIVES**

- The actual installation environments such as panel configurations, connected devices, connected wires, may affect the protection level of this unit when it is integrated in a panel system. The user may have to review the CE requirements in regard to the whole system and employ additional protective measures to ensure the CE conformity.

**ENVIRONMENT**

- When heavy dust or metal particles are present in the air, install the surge protector inside proper housing with sufficient ventilation.
- Do not install the surge protector where it is subjected to continuous vibration. Do not subject the unit to physical impact.
- Environmental temperature must be within -5 to +55°C (23 to 131°F) with relative humidity within 30 to 90% RH in order to ensure adequate life span and operation.

**DIELECTRIC STRENGTH TEST**

- Loosen the screw located at the left-center of the element and remove the element module from the base before conducting a dielectric strength testing. Otherwise the element will start discharging at a voltage exceeding the max. continuous operating voltage (Uc), which can cause insulation failure of the module.

Be sure to return the element and fasten securely after the test.

**AND ....**

- We recommend that you keep spare surge protectors so that you can replace them when necessary.
- Lightning surge can enter not only through signal lines but also through power supply lines. We recommend that you also use the surge protectors for power line for sufficient protection.

**GENERAL**

**FUNCTION & FEATURES**

- Designed specifically for resistance temperature detector (RTD) circuits
- Protecting RTD and RTD transmitters from damage caused by surges on the RTD wiring
- Absorbs surges only without affecting instrumentation signal
- No interruption of signal by unplugging surge protector element

## COMPONENT IDENTIFICATION

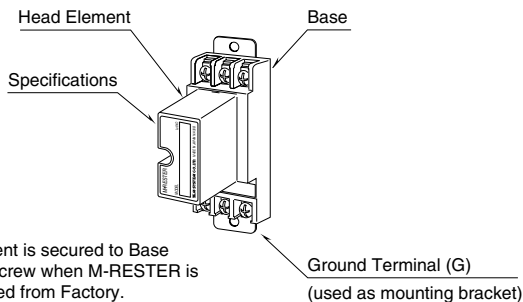

## INSTALLATION

In order to separate the head element from the base, loosen the screw located at the left-center of the element.

### ■ WALL MOUNTING

Refer to the drawings below.

#### • EXTERNAL DIMENSIONS unit: mm (inch)

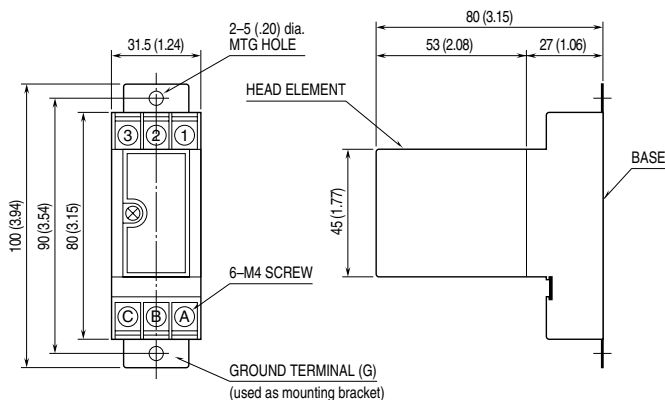

#### • MOUNTING REQUIREMENTS unit: mm (inch)

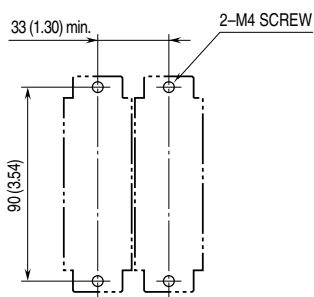

### ■ DIN RAIL MOUNTING (Only for /A33)

#### 1. MOUNTING ONTO THE ADAPTOR

Before DIN rail mounting, secure the mounting bracket of MDP to the mounting adaptor with a screw provided with this product. In this step, secure at one point.

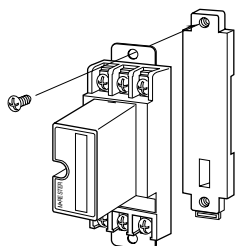

### 2. DIN RAIL MOUNTING

Set the base socket so that its mounting slider is at the bottom. Position the upper hook at the rear side of base socket on the DIN rail and push in the lower. When removing the socket, push down the mounting slider utilizing a minus screwdriver and pull.

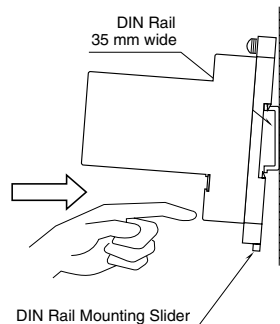

### 3. GROUNDING

Secure the mounting bracket at the other point with the other screw. In this step, secure the grounding wire together with the screw.

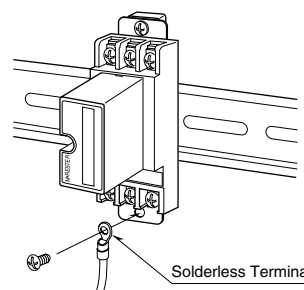

#### • MOUNTING REQUIREMENTS unit: mm (inch)

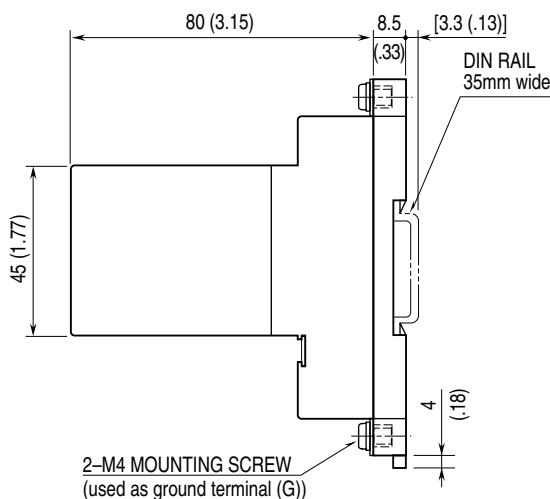

## TERMINAL CONNECTION

Connect the unit as in the diagram below.

Be sure to cross-wire between the Ground terminal (G) and that of the protected equipment. When the surge protector is connected with a device which has no ground terminal such like M-System's, ground the M-RESTER Ground terminal (G) only.

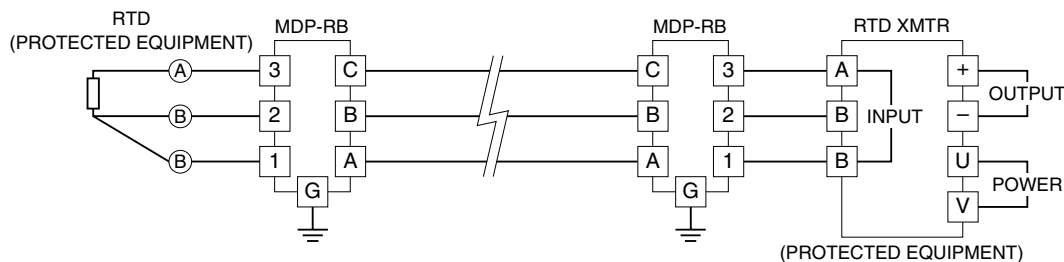

### ■ GROUNDING

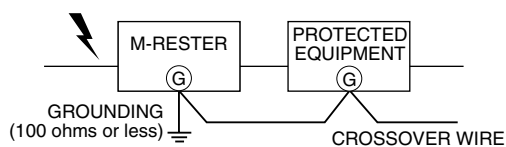

A crossover wire between M-RESTER ground and the ground or metallic housing of the equipment is required for protection.  
If the protected equipment has no ground terminal, ground the M-RESTER only.  
When the M-RESTER is mounted with DIN Rail Mounting Adapter, connect the grounding wire to the mounting screw of the M-RESTER.

## WIRING INSTRUCTIONS

### ■ SCREW TERMINAL

Torque: 0.8 N·m

## MAINTENANCE

Check surge protectors periodically. Many cases of lightning are ignored, and even lightning at a far distance often causes inductive surges.

We recommend that you check your surge protector about twice a year, before and after the rainy season. Check whenever you experience a strong lightning occurrence.

Checking procedure is explained in the following:

### ■ CHECKING WIRING

- 1) Make sure that wiring is done as instructed in the connection diagram.
- 2) Make sure that the Ground terminal (G) is connected to the metallic housing of protected equipment.
- 3) Make sure that the Ground terminal (G) is grounded to earth.

### DISCHARGE FUNCTION

The M-RESTER Tester is available for checking the element module of this surge protector.

If checking of M-RESTER tester shows negative, replace the protector.