

INSTRUCTION MANUAL

LIGHTNING SURGE PROTECTOR FOR POWER SUPPLY USE (200A)

MODEL

MH-1201
MH-2201
MH-2203

BEFORE USE

Thank you for choosing M-System. Before use, please check contents of the package you received as outlined below. If you have any problems or questions with the product, please contact M-System's Sales Office or representatives.

■ PACKAGE INCLUDES:

Lightning surge protector.....(1)

■ MODEL NO.

Confirm Model No. marking on the product to be exactly what you ordered.

■ INSTALLATION / INSTRUCTION MANUAL

This manual describes necessary points of caution when you use this product, including installation, and basic maintenance procedure.

LIMITATION APPLICABLE TO M-RESTER

The M-RESTER will protect electronics equipment from damage caused by lightning by absorbing most of the surge voltages.

However, M-RESTER may not be effective against certain extremely high voltages caused by a direct or almost direct hit by lightning.

M-RESTER must be installed according to this installation / instruction manual.

GENERALS

■ FUNCTION & FEATURES

Designed for installation where AC power enters the control panel for relatively large power consuming equipment such as large instrumentation panels, computer systems or telemetering systems in central control rooms or operation centers

■ SPECIFICATIONS

	BETWEEN LINES		LINE TO GND
	MH-1201	MH-2201/2203	
Discharge voltage (p-p)	190V min.	380V min.	410V min.
Max. surge voltage*	350V max.	700V max.	700V max.
Leakage current	≤1A including relay coil current at rated voltage		≤1mA @150V DC (MH-1201) @300V DC (MH-2201/2203)
Response time	≤0.1 μsec		
Discharge current	10000A (8 / 20 μsec.)		
Max. load current	200A		
Voltage drop	≤2V (50/60 Hz)		
Rated line voltage	100V/110V/120V AC (MH-1201) 200V/220V/240V AC (MH-2201/2203)		

*The maximum voltage that could pass through M-RESTER. Protected equipment must be able to withstand this voltage for a very short time period.

POINTS OF CAUTION

■ ENVIRONMENT

- When heavy dust or metal particles are present in the atmosphere, install M-RESTER inside proper housing and ventilate it.
- Do not install the M-RESTER where it is subjected to continuous vibration. Do not apply physical impact to the M-RESTER.
- Environmental temperature must be within -5 to +55°C with a relative humidity within 30 to 90% RH in order to ensure adequate life span and operation.

■ DIELECTRIC STRENGTH TEST

- The MH starts discharging at 410V or more voltage applied across power supply terminals and metallic housing. DO NOT conduct a dielectric strength test with the MH connected to a power source.
- For confirming insulation of the unit, conduct the dielectric strength test WITH ALL WIRES REMOVED, or conduct an insulation resistance test (@250V DC).

■ RATED CURRENT

- Be sure that the rated current of protected equipment does not exceed the maximum load current specification of the M-RESTER.
- Be sure to install a breaker which matches the current rating at the power source side of the M-RESTER.

■ AND

We recommend that you keep spare M-RESTERs so that you can replace them when necessary.

COMPONENT IDENTIFICATION

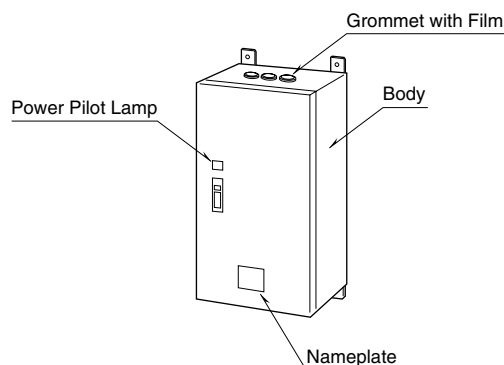

INSTALLATION

Refer to the drawings below.

EXTERNAL DIMENSIONS mm (inch)

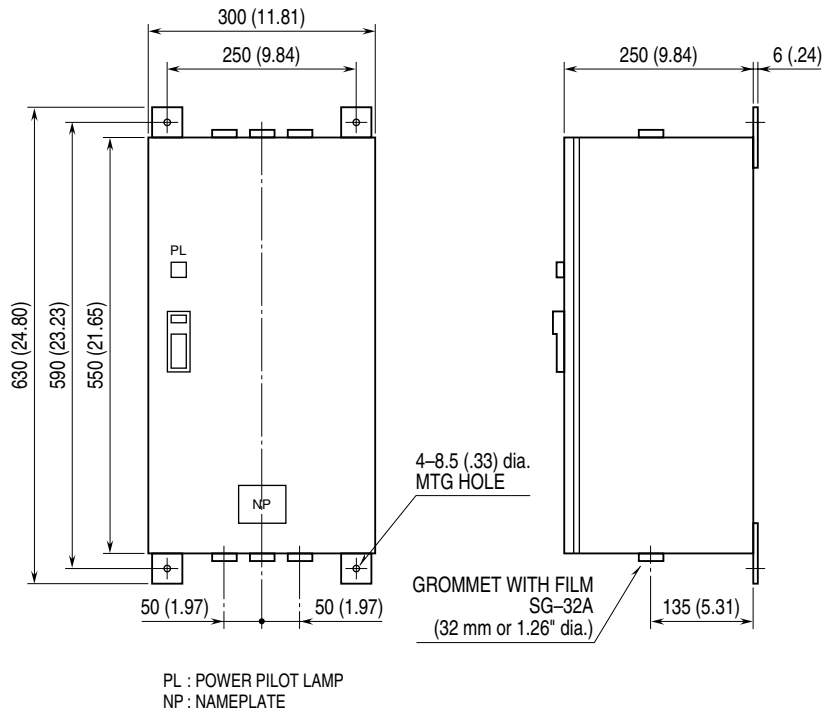

MOUNTING REQUIREMENTS mm (inch)

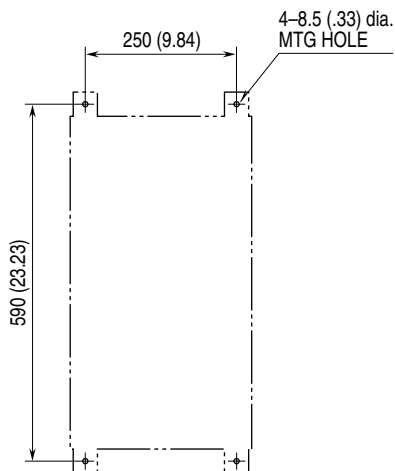

TERMINAL CONNECTIONS

Connect the unit as in the diagram below.

Be sure to cross-wire between the Ground terminal (4) and metallic housing of the protected equipment. (100Ω max.)

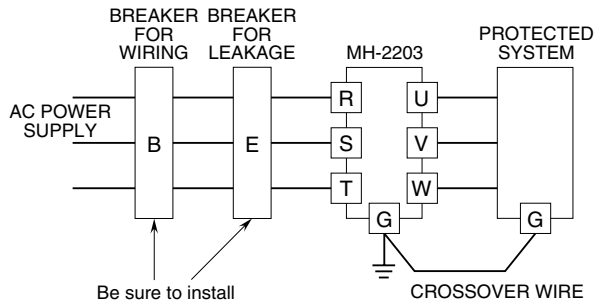
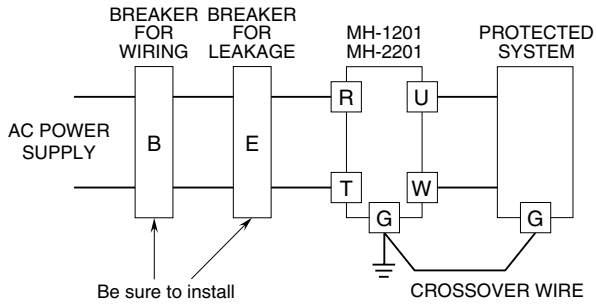

■ GROUNDING

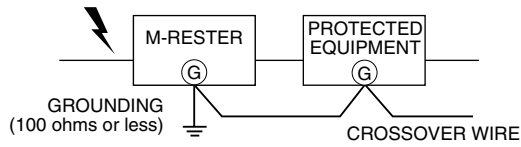

A crossover wire between M-RESTER ground and ground or metallic housing of equipment is required for protection.

If the protected equipment has no ground terminal, ground the M-RESTER only.

MAINTENANCE

Check M-RESTER periodically. Many cases of lightning are ignored, and even lightning at a far distance often causes inductive surges.

We recommend that you check your M-RESTER about twice a year, before and after the rainy season. Check whenever you experience a strong lightning occurrence.

Checking procedure is explained in the following:

■ CHECKING WIRING

- Make sure that wiring is done as instructed in the connection diagram.
- Make sure that the Ground terminal (G) is connected to the metallic housing of protected equipment.
- Make sure that the Ground terminal (G) is grounded to earth.

POWER PILOT LAMP

- Supply appropriate AC voltage through the M-RESTER and check the LEDs. When the LED is off despite that power is supplied, replace the M-RESTER.

DISCHARGE FUNCTION

Turn off the power supply and remove all wiring connected to MRESTER before testing its discharge capability as follows:

- Check resistance across the following terminals on the high resistance range of multimeter (infinite standard).
MH-1201, MH-2201: Terminals U-W, U-G, W-G
MH-2203: Terminals U-V, U-W, U-G, V-W, V-G, W-G
- Check that discharging occurs across the same terminals with a 500V DC megger. (Indicator of the megger reaches over-scale.)
- If any of the above tests shows negative, replace the M-RESTER.