

## Lightning Surge Protectors for Electronics Equipment M-RESTER

### LIGHTNING SURGE PROTECTOR FOR POWER SUPPLY (2 A, 100 / 110 / 120 V AC)

#### Functions & Features

- Designed specifically for AC power supplies up to 2 amps
- No degradation of normal (50/60 Hz) line frequency
- Power indicator lamp provided

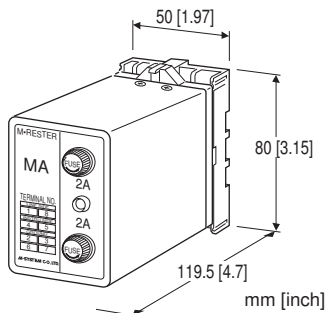

### MODEL: MA-100[1]

#### ORDERING INFORMATION

- Code number: MA-100[1]
- Specify a code from below for [1].  
(e.g. MA-100/CE)

#### [1] OPTIONS

##### Standards & Approvals

- blank: Without CE  
/CE: CE marking

#### GENERAL SPECIFICATIONS

- Construction:** Plug-in  
**Connection:** M3.5 screw terminals (torque 0.8 N·m)  
**Screw terminal:** Chromated steel  
**Housing material:** Flame-resistant resin (black)  
**Monitor lamp:** Green neon lamp turns on when the power is supplied.

#### INSTALLATION

- Operating temperature:** -5 to +55°C (23 to 131°F)  
**Operating humidity:** 30 to 90 %RH (non-condensing)  
**Mounting:** Surface or DIN rail  
**Weight:** 330 g (0.73 lb)

#### PERFORMANCE

##### Discharge voltage (peak voltage)

- Line to line: 190 V min.  
Line to ground: 410 V min.

##### Maximum surge voltage

- Line to line: 350 V max.  
Line to ground: 700 V max.

(The maximum voltage that could pass through M-RESTER. Protected equipment must be able to withstand this voltage for very short time period.)

##### Response time: $\leq 0.1 \mu\text{sec}$ .

##### Leakage current

- Line to line:  $\leq 1 \text{ mA}$  at 150 V DC  
Line to ground:  $\leq 1 \text{ mA}$  at 300 V DC

##### Max. discharge current (Imax): 1000 A (8/ 20 $\mu\text{sec}$ .)

##### Max. load current: 2 A

##### Voltage drop: $\leq 2 \text{ V}$ (50/60 Hz)

##### Rated line voltage: 100 V / 110 V / 120 V AC

#### STANDARDS & APPROVALS

##### EU conformity:

- EMC Directive  
 EMI EN 61000-6-4  
 EMS EN 61000-6-2  
 Low Voltage Directive  
 EN 61010-1  
 Installation Category II  
 Pollution Degree 2  
 RoHS Directive

## CONNECTION EXAMPLES

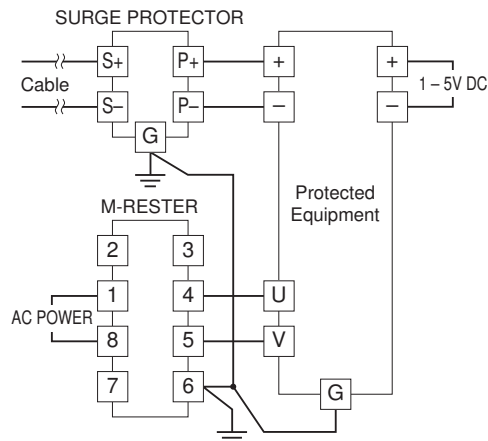

Ground one of the terminals 2, 3, 6 and 7.

## GROUNDING

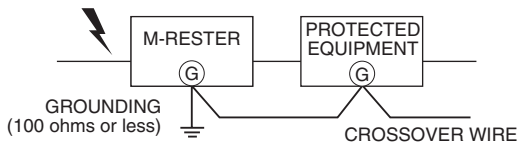

A crossover wire between M-RESTER ground and ground or metallic housing of equipment is required for protection.  
If the protected equipment has no ground terminal, ground the M-RESTER only.

## EXTERNAL DIMENSIONS & TERMINAL ASSIGNMENT unit: mm [inch]

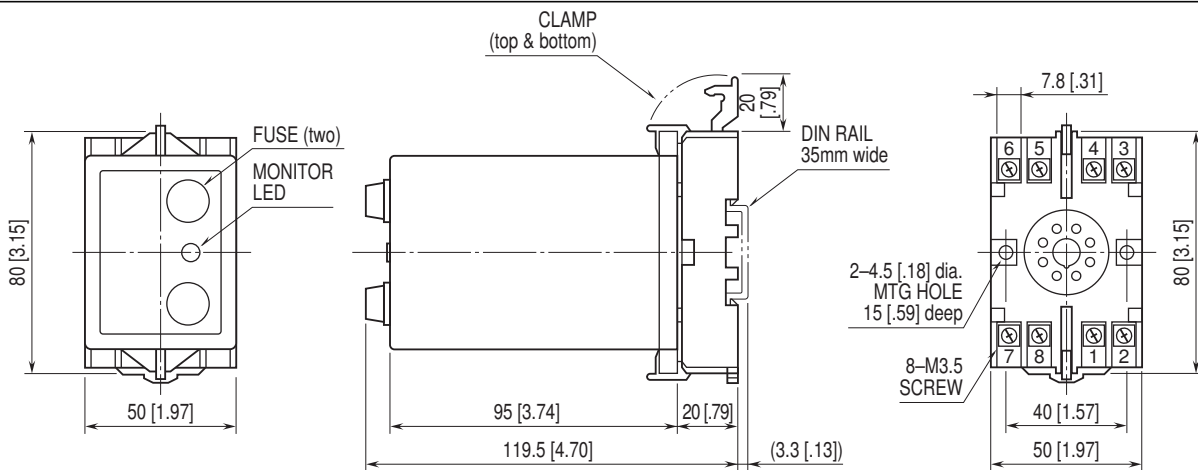

• When mounting, no extra space is needed between units.

**SCHEMATIC CIRCUITRY**

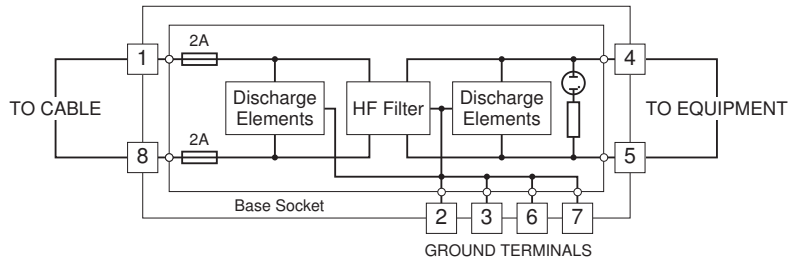

Specifications are subject to change without notice.