

BEFORE USE

Thank you for choosing M-System. Before use, check the contents of the package you received as outlined below.

If you have any problems or questions with the product, please contact M-System's Sales Office or representatives.

■ PACKAGE INCLUDES:

Lightning surge protector (body + base socket).....(1)

■ MODEL NO.

Confirm Model No. marking on the product to be exactly what you ordered.

■ INSTRUCTION MANUAL

This manual describes necessary points of caution when you use this product, including installation, connection and basic maintenance procedures.

LIMITATION APPLICABLE TO M-RESTER

The M-RESTER will protect electronics equipment from damage caused by lightning by absorbing most of the surge voltages.

However, M-RESTER may not be effective against certain extremely high voltages caused by a direct or almost direct hit by lightning.

M-RESTER must be installed according to this installation / instruction manual.

GENERAL

■ FUNCTION & FEATURES

- Designed specifically for AC power supplies up to 5 amps

■ SPECIFICATIONS

	Between Lines		Line to Gnd
	MAA-100	MAA-200	
Discharge voltage	190V min.	410V min.	400V min.
Max. surge voltage*	380V max.	700V max.	800V max.
Leakage current	≤ 26mA @100V AC	≤ 13mA @200V AC	≤ 0.1A @300V AC
Response time	≤ 0.01 μsec.		
Discharge current capacity	10000A (8 / 20 μsec.)		
Max. load current	5A		
Internal series resistance	≤ 0.5 Ω including return		

* The maximum voltage that could pass through M-RESTER. Protected equipment must be able to withstand this voltage for a very short time period.

POINTS OF CAUTION

■ CONFORMITY WITH EU DIRECTIVES

- This equipment is suitable for Pollution Degree 2, Measurement Category II (alarm output, transient voltage 1500V) and Installation Category II (transient voltage 2500V). Reinforced insulation (alarm output to power input: 300V) is maintained. Prior to installation, check that the insulation class of this unit satisfies the system requirements.

- Altitude up to 2000 meters.
- The equipment must be mounted inside a panel.
- The equipment must be installed such that appropriate clearance and creepage distances are maintained to conform to CE requirements. Failure to observe these requirements may invalidate the CE conformance.
- The actual installation environments such as panel configurations, connected devices, connected wires, may affect the protection level of this unit when it is integrated in a panel system. The user may have to review the CE requirements in regard to the whole system and employ additional protective measures to ensure the CE conformity.

■ POWER INPUT RATING & OPERATIONAL RANGE

- Locate the power input rating marked on the product and confirm its operational range as indicated below:

MAA-100: 90 – 132V, 50/60 Hz, approx. 2VA

MAA-200: 180 – 264V, 50/60 Hz, approx. 2VA

■ GENERAL PRECAUTIONS

- Before you remove the unit from its base socket or mount it, turn off the power supply and the signal for safety.

■ ENVIRONMENT

- Indoor use.
- When heavy dust or metal particles are present in the air, install the surge protector inside proper housing with sufficient ventilation.
- Do not install the surge protector where it is subjected to continuous vibration. Do not subject the unit to physical impact.
- Environmental temperature must be within -5 to +55°C (23 to 131°F) with relative humidity within 30 to 90% RH in order to ensure adequate life span and operation.

■ WIRING

- Remove the wiring to the ground terminals (2 or 7) before conducting an insulation test. Otherwise the element will start discharging at discharge voltage, which will be judged as insulation failure. Be sure to secure the wiring after the testing is complete. Incomplete wiring can actually cause lightning intrusion.

■ RATED CURRENT

- Be sure that the total current rating of the protected equipment does not exceed the maximum load current capacity of the MAA. Install a breaker at the supply side.

■ AND

- The unit is designed to function as soon as power is supplied, however, a warm up for 10 minutes is required for satisfying surge counter backup function described in the data sheet.
- We recommend that you keep spare surge protectors so that you can replace them when necessary.
- Lightning surge can enter not only through power supply lines but also through signal lines. We recommend that you also use the surge protectors for signal line for sufficient protection.

COMPONENT IDENTIFICATION

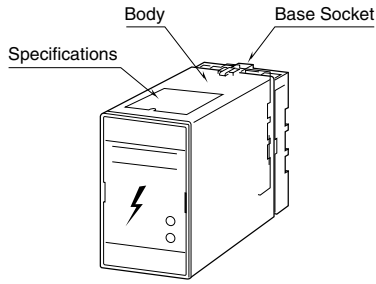

FRONT PANEL CONFIGURATION

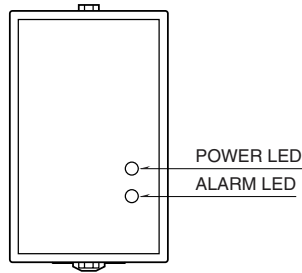

POWER LED (green)

The green LED turns on while the power is supplied; turns off when the power supply is removed and the alarm output is turned on.

ALARM LED

The tricolor LED turns off, then on in green, amber, and red according to the unit status.

- 1) Remains OFF when the power supply is first turned on.
- 2) Green: The unit has received one or more surges. (The LED does not turn on when the power is not supplied.)
- 3) Amber: Replacement is recommended.
- 4) Red: The life span has ended. Replace the unit immediately. The alarm output is turned on.

INSTALLATION

Detach the yellow clamps located at the top and bottom of the unit for separate the body from the base socket.

DIN RAIL MOUNTING

Set the base socket so that its DIN rail adaptor is at the bottom. Position the upper hook on the DIN rail and push in the lower. When removing the socket, push down the DIN rail adaptor utilizing a minus screwdriver and pull.

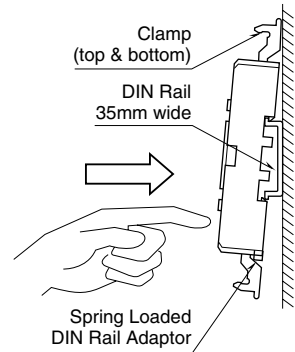

WALL MOUNTING

Refer to "EXTERNAL DIMENSIONS."

Shape and size of the base socket are slightly different with various socket types.

TERMINAL CONNECTIONS

Connect the unit as in the diagram below or refer to the connection diagram on the front of the unit. Be sure to make cross-wiring as shown in "GROUNDING". If the protected equipment is not provided with a G terminal, ground only this unit's G terminal.

EXTERNAL DIMENSIONS unit: mm (inch)

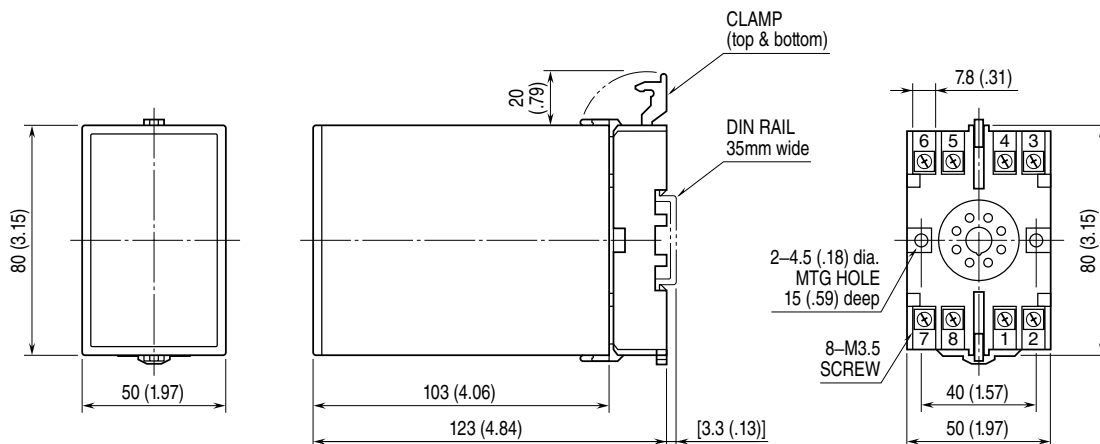

• When mounting, no extra space is needed between units.

■ CONNECTION DIAGRAM

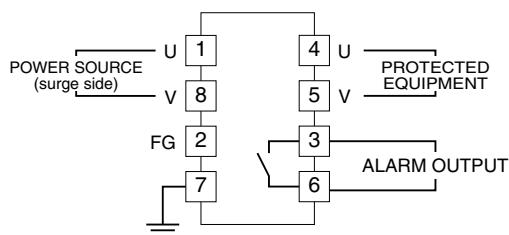

■ GROUNDING

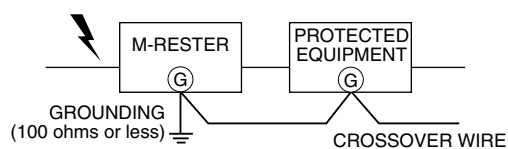

A crossover wire between M-RESTER ground and the ground or metallic housing of the equipment is required for protection. If the protected equipment has no ground terminal, ground the M-RESTER only.

MAINTENANCE

While the ALARM LED is green, regular inspections are recommended.

When it is turned to amber, replacement of the unit is recommended.

When it is turned to and remain red, replace the unit immediately.

CAUTION !

Before replacing the unit, be sure to turn off the power supply for safety. Other factors such like an alarm system connected to the line should also be considered.

The life monitoring circuit remain alive due to the internal backup power even when the external power supply is removed. The LED is turned off in that case. The backup power is normally effective for approximately one week depending upon environmental conditions.