

Lightning Surge Protectors for Electronics Equipment M-RESTER

LIGHTNING SURGE PROTECTOR FOR POWER SUPPLY USE

(DC power use; life monitor)

Functions & Features

- Designed specifically for DC power supplies up to 5 amps
- Life monitor function helps you to decide when you should replace the M-RESTER; reduces maintenance and prevents downtime
- LED display and alarm contact output indicate the degradation and life span of the surge protection circuits
- No power supply interruption even when the unit is degraded or at the end of its life

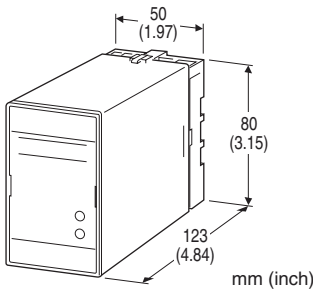

DEL: MDHA-[1]

ORDERING INFORMATION

- Code number: MDHA-[1]
- Specify a code from below for [1]
- (e.g. MDHA-24)

[1] OPERATIONAL VOLTAGE

- 12:** 12 V DC
- 24:** 24 V DC

GENERAL SPECIFICATIONS

- Construction:** Plug-in
- Connection:** M3.5 screw terminals (torque 0.8 N·m)
- Screw terminal:** Chromated steel
- Housing material:** Flame-resistant resin (black)
- Alarm indicators**
- Power:** The green LED turns on while the circuit is alive and the internal fuse on the voltage limiter side is not blown; and is off when the power supply is removed or this fuse is blown.
- Alarm:** Tricolor LED (green/amber/red)
- Remains off when the power supply is first turned on.

- Green: The unit has received one or more surges.
- Amber: Replacement is recommended.
- Red: The life span has ended.

Alarm contact

The N.C. contact is on when the life span of the discharge elements has ended, when the voltage limiter has degraded, when the fuses are blown, and/or when the power supply is removed.

Rating: 125 V AC @ 0.5 A (cos ϕ = 1)
30 V DC @ 1 A (resistive load)

Maximum switching voltage: 125 V AC or 110 V DC

Maximum switching power: 62.5 VA or 30 W

Minimum load: 5 V DC @ 1 mA

Life status table

POWER LED	ALARM LED	ALARM CONTACT	STATUS	REPLACEMENT
ON	OFF	OFF	Normal (no surge)	No Need
	Green		Normal (multiple hits)	
	Amber		Near End	Without Delay
	Red		End (degraded)	Now
OFF	----	----	Power supply removed or End (degraded)	Now if the power supply is normal.

INSTALLATION

- Operating temperature:** -5 to +55°C (23 to 131°F)
- Operating humidity:** 30 to 90 %RH (non-condensing)
- Mounting:** Surface or DIN rail
- Weight:** 500 g (1.1 lbs)

PERFORMANCE

- Operational line voltage:**
 - 10.8 - 13.2V DC (MDHA-12)
 - 21.6 - 26.4V DC (MDHA-24)
- Discharge voltage (peak voltage)**
 - Line to line:
 - ±15 V min. (MDHA-12)
 - ±30 V min. (MDHA-24)
 - Line to ground: ±160 V min.
- Max. surge voltage (Up)**
 - Line to line:
 - ±80 V max. (MDHA-12)
 - ±120 V max. (MDHA-24)
 - Line to ground: ±700 V max.

(This is the maximum voltage that could pass through M-RESTER. Protected equipment must be able to withstand this voltage for a very short time period.)
- Response time:**
 - Line to line: ≤ 4 nsec.
 - Line to ground: ≤ 20 nsec.
- Leakage current**

- Line to line: $\leq 40 \text{ mA @ } 13.2 \text{ V DC (MDHA-12)}$
 $\leq 40 \text{ mA @ } 26.4 \text{ V DC (MDHA-24)}$
 - Line to ground: $\leq 0.1 \text{ mA @ } 160 \text{ V DC}$
- Discharge current capacity:** 10000 A (8/ 20 $\mu\text{sec.}$)
Maximum load current: 5 A
Insulation resistance: $\geq 100 \text{ M}\Omega$ with 500 V DC
Dielectric strength: 1500 V AC @ 1 minute
 (line or ground to alarm output)
Internal series resist.: $\leq 0.2 \Omega$ including return

EXTERNAL VIEW

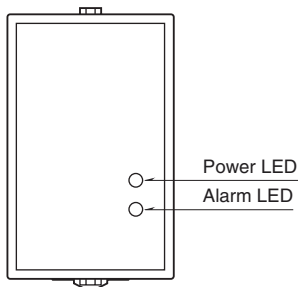

GROUNDING

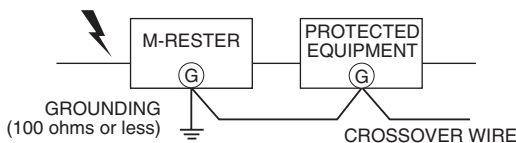

A crossover wire between M-RESTER ground and ground or metallic housing of equipment is required for protection.
 If the protected equipment has no ground terminal, ground the M-RESTER only.

EXTERNAL DIMENSIONS & TERMINAL ASSIGNMENTS unit: mm (inch)

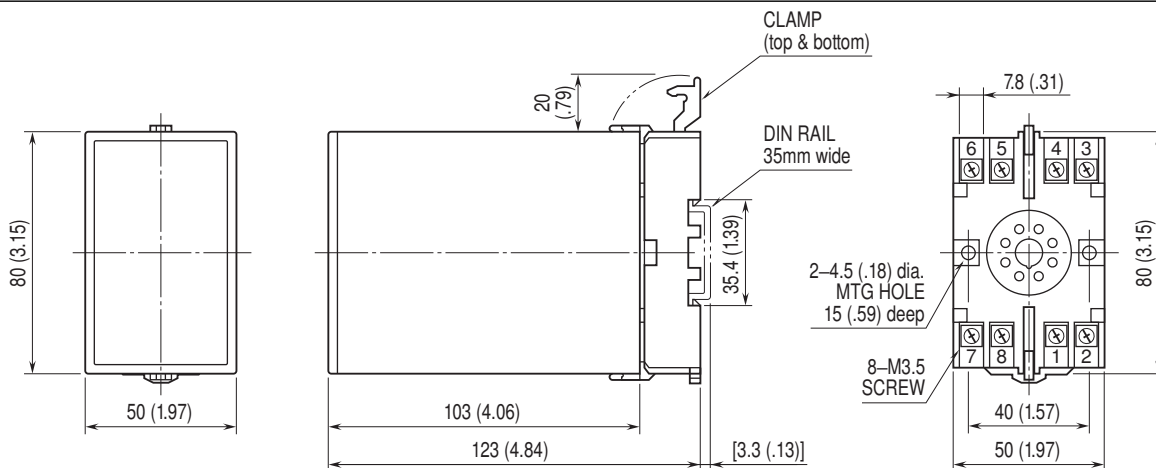

• When mounting, no extra space is needed between units.

SCHEMATIC CIRCUITRY & CONNECTION DIAGRAM

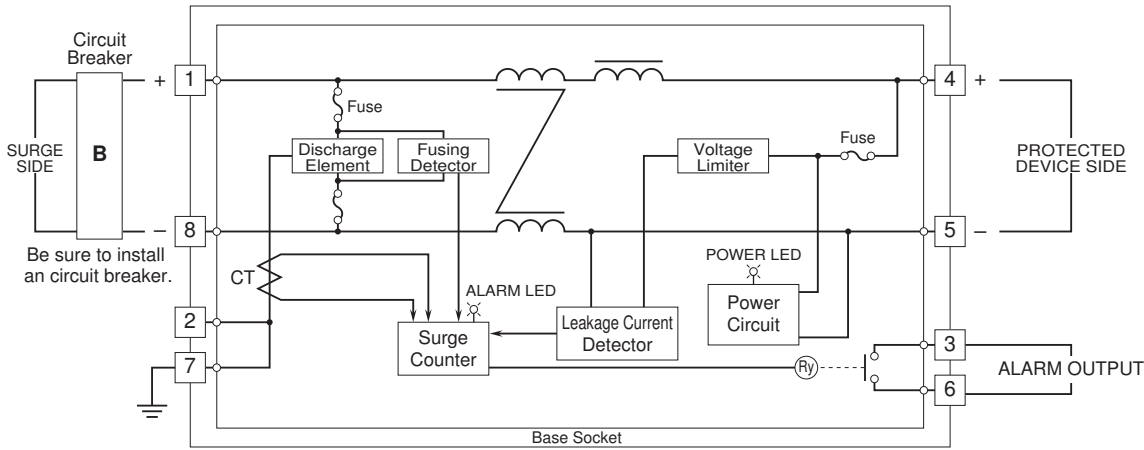

Specifications are subject to change without notice.