

Lightning Surge Protectors for Electronics Equipment M-RESTER

LIGHTNING SURGE PROTECTOR FOR PROFIBUS-PA

Functions & Features

- Designed specifically for the network
- No interruption of transmission signal by unplugging the head element module

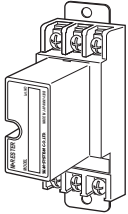

MODEL: MDP-PA[1]

ORDERING INFORMATION

- Code number: MDP-PA[1]
Specify a code from below for [1].
(e.g. MDP-PA/A33/Q)
- Specify the specification for option code /Q
(e.g. /C01)

[1] OPTIONS (multiple selections)

DIN Rail Mounting Adapter

blank: Without

/A33: With adapter (model A-33)

Other Options

blank: none

/Q: Option other than the above (specify the specification)

SPECIFICATIONS OF OPTION: Q

COATING (For the detail, refer to M-System's web site.)

/C01: Silicone coating

/C02: Polyurethane coating

/C03: Rubber coating

APPLICABLE NETWORK

PROFIBUS-PA, Foundation Fieldbus and other networks
complied with IEC 61158-2

Note 1: This unit is not approved for classified locations.

Note 2: Power supply to the bus must be limited to 500 mA
or less.

GENERAL SPECIFICATIONS

Construction: Plug-in

Connection: M4 screw terminals (torque 0.8 N·m)

Screw terminal: Nickel-plated steel

Housing material: Flame-resistant resin (black)

INSTALLATION

Operating temperature: -5 to +55°C (23 to 131°F)

Operating humidity: 30 to 90 %RH (non-condensing)

Mounting: Surface or DIN rail

Weight: 100 g (0.22 lb), standard; 125 g (0.28 lb), with DIN
rail mounting adapter

PERFORMANCE

Max. continuous operating voltage (Uc):

Line to line: 27 V min

Line to earth: ±160 V min

SHLD to earth: ±160 V min

Voltage protection level (Up):

- @ 2 kV (1 kA)

Line to line: ±60 V max.

Line to earth: ±600 V max.

SHLD to earth: ±600 V max.

Response time:

Line to line: ≤ 4 nsec.

Line or SHLD to earth: ≤ 20 nsec.

Leakage current:

Line to line: ≤ 5 μA @ ±27 V

Line to earth: ≤ 5 μA @ ±160 V

SHLD to earth: ≤ 5 μA @ ±160 V

Max. discharge current (Imax): 5000 A (8 / 20 μs)

Nominal current (In): 500 mA

Internal series resistance: ≤ 3.3 Ω including return

Capacitance @ 1 MHz:

Line to line: ≤ 1500 pF

Line to earth: ≤ 100 pF

SHLD to earth: ≤ 100 pF

STANDARDS & APPROVALS

Surge protection: IEC 61643-21: 2000

(Categories C1, C2)

CONNECTION EXAMPLES

CONNECTION DIAGRAM

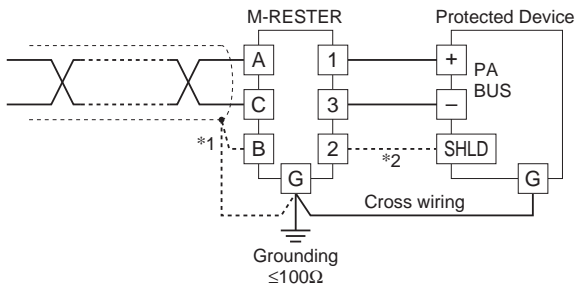

- *1. Cross wire to the surge protector's 'G' terminal when grounding the shield wire. If the shield wire is not to be grounded, connect it to 'B' terminal.
- *2. Follow instructions provided with the protected device whether '2' terminal should be connected or not. However, if the shield terminal of the protected device is not isolated from PA BUS, DO NOT connect '2' terminal to the protected device.

NETWORK CONFIGURATION

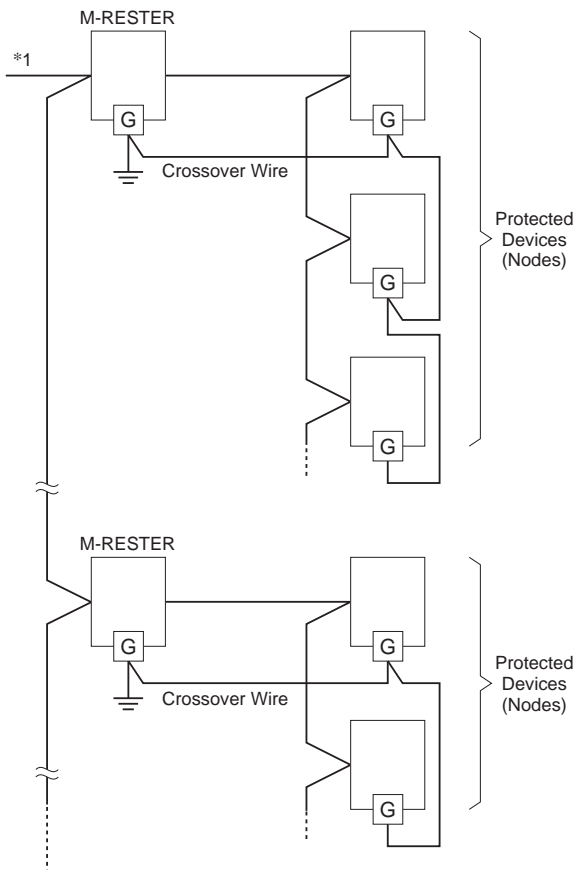

- *1. Fieldbus devices complying with IEC 61158-2 operate by a supply voltage between 9V and 32V DC. Take the MDP-PA's internal series resistance into consideration when determining the cable distance if there is a large current flow on the bus line.

When the distance between nodes are relatively long (e.g. grouped and separated by cabinets), install the MDP-PA by each group of devices. Insert the MDP-PA at the surge side of the network. For detailed information on the network, refer to that provided by PROFIBUS International or Fieldbus Foundation.

GROUNDING

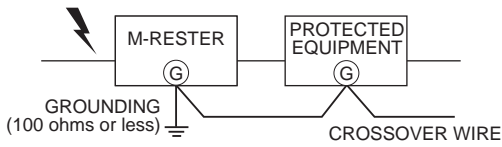

A crossover wire between M-RESTER ground and the ground or metallic housing of the equipment is required for protection. If the protected equipment has no ground terminal, ground the M-RESTER only. When the M-RESTER is mounted with DIN Rail Mounting Adapter, connect the grounding wire to the mounting screw of the M-RESTER.

EXTERNAL DIMENSIONS & TERMINAL ASSIGNMENTS unit: mm (inch)

■ STANDARD

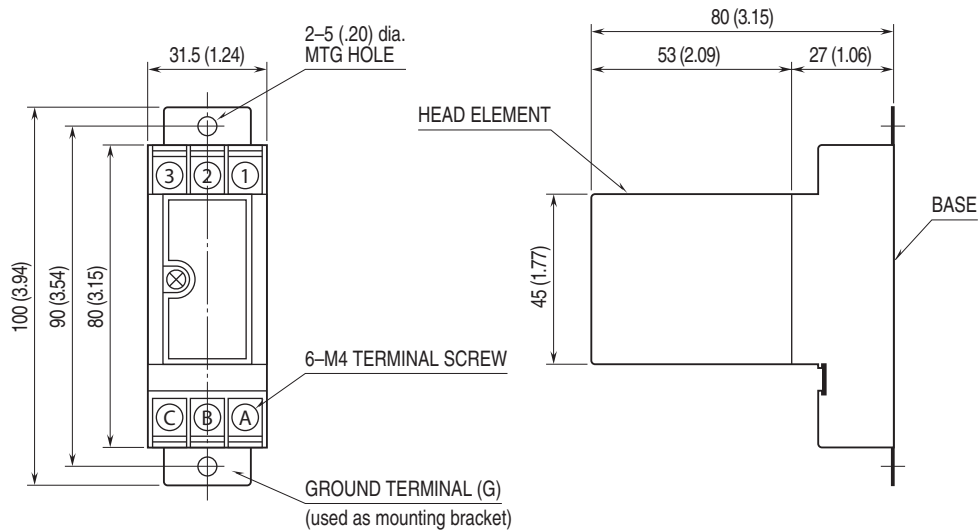

■ WITH DIN RAIL MOUNTING ADAPTER

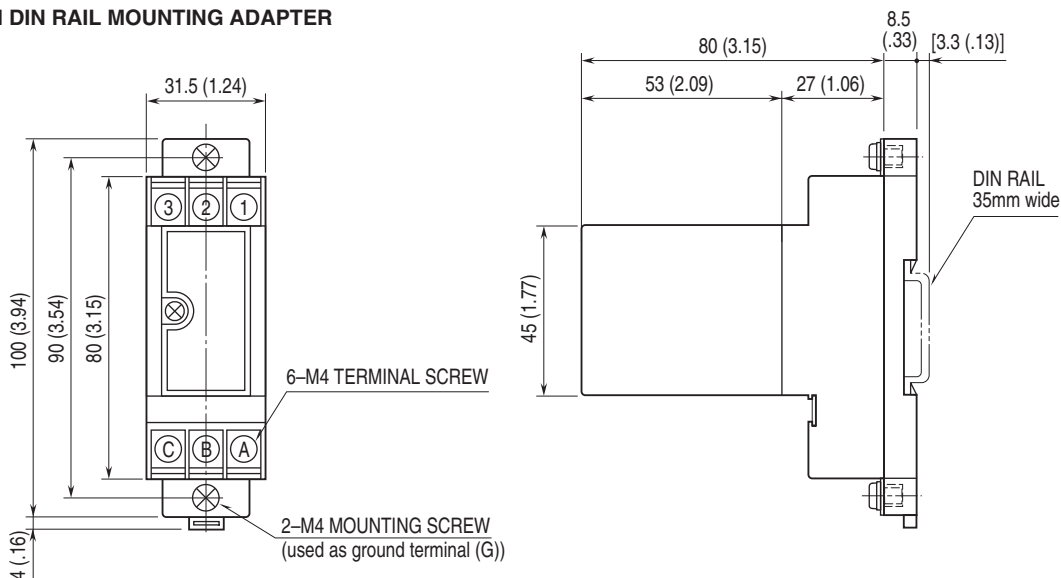

MOUNTING REQUIREMENTS unit: mm (inch)

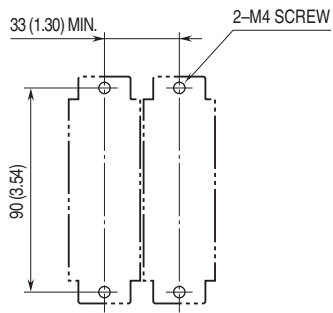

SCHEMATIC CIRCUITRY & CONNECTION DIAGRAM

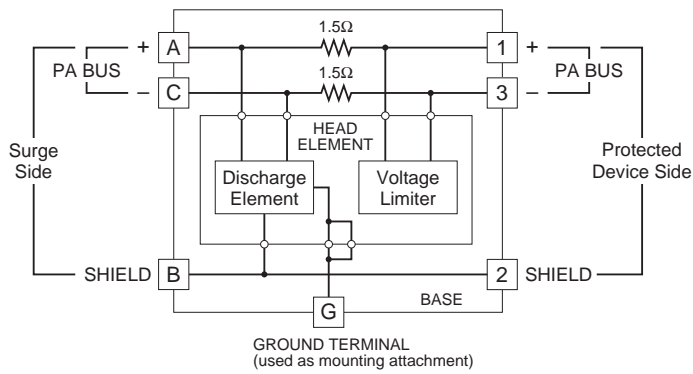

Specifications are subject to change without notice.