

Plug-in Signal Conditioners K-UNIT

CURRENT LOOP SUPPLY

(for level transmitter use)

Functions & Features

- Powering a 4 - 20 mA DC current loop
- Shortcircuit protection
- Applicable to smart transmitters
- Usable as 4 - 20 mA isolator
- Wide span adjustment range
- High-density mounting

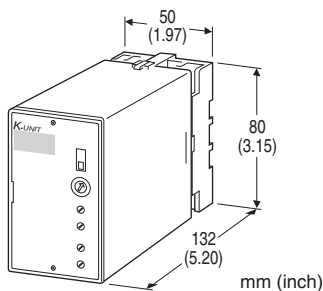

MODEL: KWLD-A6-[1][2]

ORDERING INFORMATION

- Code number: KWLD-A6-[1][2]
- Specify a code from below for each of [1] and [2].
(e.g. KWLD-A6-B/Q)
- Specify the specification for option code /Q
(e.g. /C01/S01)

INPUT

Current

4 - 20 mA DC (Input resistance 250 Ω)

OUTPUT 1

Current

A: 4 - 20 mA DC (Load resistance 600 Ω max.)

OUTPUT 2

Voltage

6: 1 - 5 V DC (Load resistance 5000 Ω min.)

[1] POWER INPUT

AC Power

- B: 100 V AC
- C: 110 V AC
- D: 115 V AC

F: 120 V AC

G: 200 V AC

H: 220 V AC

J: 240 V AC

DC Power

S: 12 V DC

R: 24 V DC

[2] OPTIONS

blank: none

/Q: With options (specify the specification)

SPECIFICATIONS OF OPTION: Q (multiple selections)

COATING (For the detail, refer to M-System's web site.)

/C01: Silicone coating

/C02: Polyurethane coating

/C03: Rubber coating

TERMINAL SCREW MATERIAL

/S01: Stainless steel

GENERAL SPECIFICATIONS

Construction: Plug-in

Connection: M3.5 screw terminals

Screw terminal: Chromated steel (standard) or stainless steel

Housing material: Flame-resistant resin (black)

Isolation: Input to output 1 to output 2 to power

Overrange output: Approx. -10 to +110 %

Zero adjustment: ±10 % of the input 4 - 20 mA (front)

Output 2 zero adjustment: ±2 % of the calibrated range (front)

Span adjustment: 10 - 100 % of the input 4 - 20 mA (front)

Output 2 span adjustment: ±2 % of the calibrated range (front)

Coarse span adjustment: Rotary switch (front)

Load test switch: Supply output is removed with OFF.

SUPPLY OUTPUT

(Across the terminals 4 - 5)

Output voltage: 24 - 28 V DC with no load

18 V DC min. at 20 mA

Current rating: ≤ 22 mA DC

- Shortcircuit Protection

Current limited: 30 mA max.

Protected time duration: No limit

INPUT SPECIFICATIONS

- DC Current: Input resistor incorporated

INSTALLATION

Power input

•**AC:** Operational voltage range: rating $\pm 10\%$,
50/60 ± 2 Hz, approx. 3.5 VA

•**DC:** Operational voltage range: rating $\pm 10\%$
ripple 10 %p-p max., approx. 3 W (125 mA at 24 V)

Operating temperature: -5 to +55°C (23 to 131°F)

Operating humidity: 30 to 90 %RH (non-condensing)

Mounting: Surface or DIN rail

Weight: 400 g (0.88 lb)

PERFORMANCE in percentage of span

Accuracy: $\pm 0.1\%$ (Coarse span adjustment SW set to '0')

Temp. coefficient: $\pm 0.02\%/^{\circ}\text{C}$ ($\pm 0.01\%/^{\circ}\text{F}$) (Coarse span adjustment SW set to '0')

Response time: ≤ 0.2 sec. (0 - 90 %)

Line voltage effect: $\pm 0.1\%$ over voltage range

Insulation resistance: $\geq 100\text{ M}\Omega$ with 500 V DC

Dielectric strength:

2000 V AC @1 minute (input to output 1 or output 2 to power to ground)

1000 V AC @1 minute (output 1 to output 2)

EXTERNAL VIEW

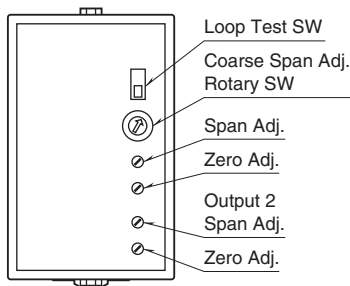

EXTERNAL DIMENSIONS & TERMINAL ASSIGNMENTS unit: mm (inch)

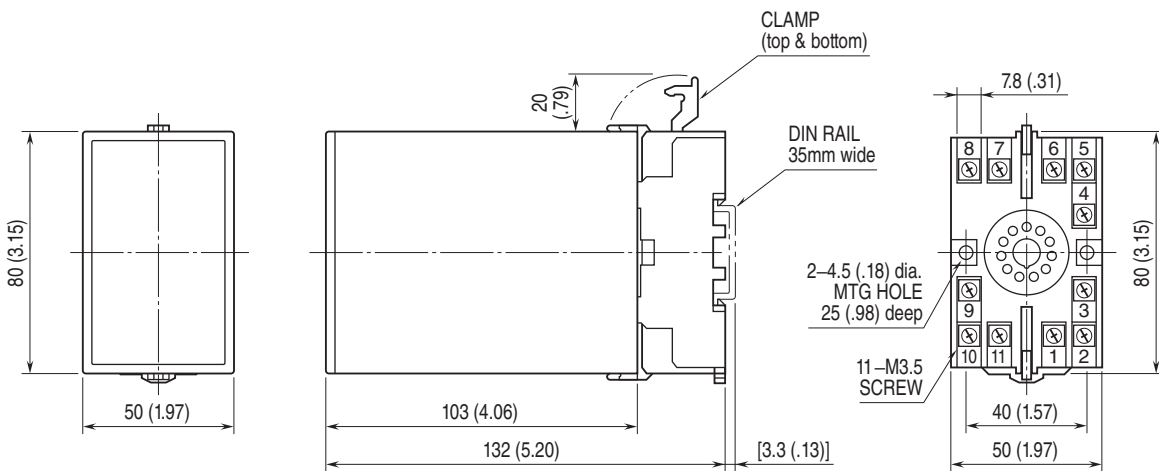

• When mounting, no extra space is needed between units.

SCHEMATIC CIRCUITRY & CONNECTION DIAGRAM

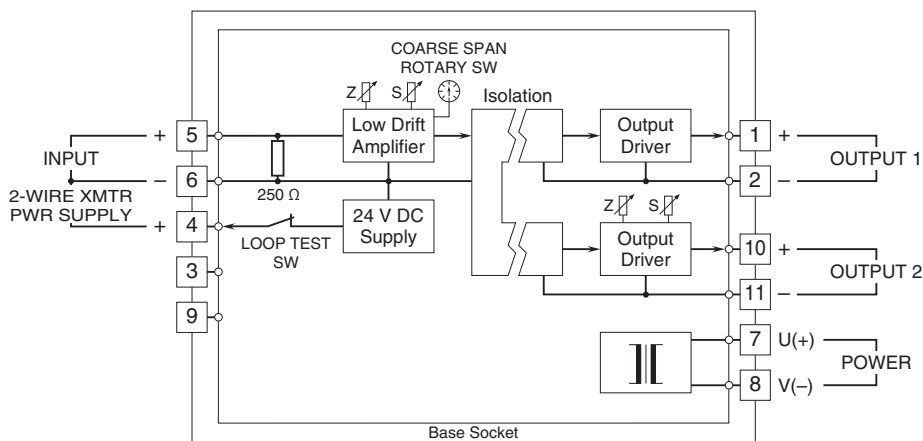

■ When Used as DC Supply

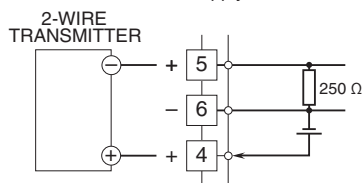

■ When Used as Isolator

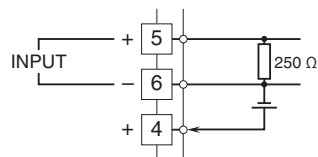

Specifications are subject to change without notice.