

Plug-in Signal Conditioners K-UNIT

WATT TRANSDUCER

(self-powered, with pulse output)

Functions & Features

- Providing a DC output signal and pulse totalizer signal in proportion to AC active power
- Convenient pulse unit output (Wh×10ⁿ)
- Measuring bidirectional power flow
- DC output containing little ripple is ideal for computer input
- "Time division multiplication" method accepts distorted waveforms
- High-density mounting

Typical Applications

- Centralized monitoring and control of power management system in a manufacturing facility or building
- SCR – Silicon Controlled Rectifier

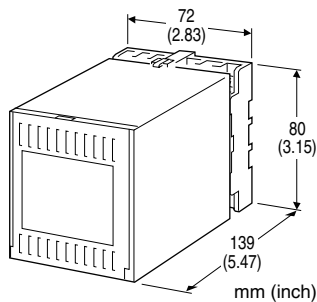

MODEL: KUWTN-[1][2][3][4][5]

ORDERING INFORMATION

- Code number: KUWTN-[1][2][3][4][5]
- Specify a code from below for each of [1] through [5].
(e.g. KUWTN-11A4/Q)
- Calibration range (e.g. -750 – +750 W)
- VT ratio, CT ratio (e.g. VT 3300 / 110 V, CT 250 / 5 A)
- Special DC output range (For codes Z & 0)
- Pulse output (e.g. 6.666 Wh/pulse)
- Specify the specification for option code /Q
(e.g. /C01/S01)

How To Determine Pulse Unit

[example]

3-phase / 3-wire, VT 3300 / 110 V, CT 250 / 5 A,
calibration range 750 W

- **From Pulse Unit** 10 [kWh/pulse]
- $$10 \text{ [kWh/pulse]} \div ((3300 \div 110) \times (250 \div 5)) = 6.666 \times 10^{-3} \text{ [kWh/pulse]}$$

= 6.666 [Wh/pulse]

- **From Pulse Rate** 150 [pulse/kWh]

$1 \div 150 \text{ [pulse/kWh]}$

= $6.666 \times 10^{-3} \text{ [kWh/pulse]}$

= 6.666 [Wh/pulse]

- **From Frequency** 0.03125 Hz (at 100 %)

$750 \text{ [W]} \div (0.03125 \text{ [Hz]} \times 3600 \text{ [sec.]}) = 6.666 \text{ [Wh/pulse]}$

[1] CONFIGURATION

- 1: 3-phase / 3-wire
- 2: Single-phase / 2-wire
- 3: Single-phase / 3-wire
- 4: 3-phase / 4-wire

[2] INPUT (unbalanced load)

- 1: 110 V / 5 A AC
- 2: 110 V / 1 A AC
- 3: 220 V / 1 A AC
- 4: 220 V / 5 A AC
- 5: 220 V / 380 V / 1 A AC (3-phase / 4-wire)
- 6: 220 V / 380 V / 5 A AC (3-phase / 4-wire)
- 7: 110 V / 190 V / 1 A AC (3-phase / 4-wire)
- 8: 110 V / 190 V / 5 A AC (3-phase / 4-wire)
- A: 100 V / 200 V / 1 A AC (single-phase / 3-wire)
- B: 100 V / 200 V / 5 A AC (single-phase / 3-wire)

[3] DC OUTPUT

Current

- A: 4 – 20 mA DC (Load resistance 600 Ω max.)
- B: 2 – 10 mA DC (Load resistance 1200 Ω max.)
- C: 1 – 5 mA DC (Load resistance 2400 Ω max.)
- D: 0 – 20 mA DC (Load resistance 600 Ω max.)
- E: 0 – 16 mA DC (Load resistance 750 Ω max.)
- F: 0 – 10 mA DC (Load resistance 1200 Ω max.)
- G: 0 – 1 mA DC (Load resistance 12 kΩ max.)
- J: 0 – 5 mA DC (Load resistance 2400 Ω max.)
- GW: -1 – +1 mA DC (Load resistance 10 kΩ max.)
- Z: Specify current (See OUTPUT SPECIFICATIONS)

Voltage

- 1: 0 – 10 mV DC (Load resistance 10 kΩ min.)
- 2: 0 – 100 mV DC (Load resistance 100 kΩ min.)
- 3: 0 – 1 V DC (Load resistance 1000 Ω min.)
- 4: 0 – 10 V DC (Load resistance 10 kΩ min.)
- 5: 0 – 5 V DC (Load resistance 5000 Ω min.)
- 6: 1 – 5 V DC (Load resistance 5000 Ω min.)
- 1W: -10 – +10 mV DC (Load resistance 10 kΩ min.)
- 2W: -100 – +100 mV DC (Load resistance 100 kΩ min.)
- 3W: -1 – +1 V DC (Load resistance 1000 Ω min.)
- 4W: -10 – +10 V DC (Load resistance 10 kΩ min.)
- 5W: -5 – +5 V DC (Load resistance 5000 Ω min.)
- 0: Specify voltage (See OUTPUT SPECIFICATIONS)

[4] PULSE OUTPUT

2: Open collector

3: Relay contact (mercury relay)

Suffix code 3 has been discontinued. Select code 4 instead.

4: Power photo MOSFET relay

[5] OPTIONS

blank: none

/Q: With options (specify the specification)

SPECIFICATIONS OF OPTION: Q (multiple selections)

COATING (For the detail, refer to our web site.)

/C01: Silicone coating

/C02: Polyurethane coating

/C03: Rubber coating

TERMINAL SCREW MATERIAL

/S01: Stainless steel

GENERAL SPECIFICATIONS

Construction: Plug-in

Connection: M3.5 screw terminals

Screw terminal: Chromated steel (standard) or stainless steel

Housing material: Flame-resistant resin (black)

Isolation: Voltage input to current input to DC output to pulse output

Computation: Time division multiplication

Overrange output: Approx. -10 - +120 % at 1 - 5 V

Zero adjustment(DC output): -5 to + 5 % (front)

Span adjustment(DC output): 95 to + 105 % (front)

INPUT SPECIFICATIONS

Frequency: 50 or 60 Hz

• Voltage Input

Operational range: 85 - 110 % of rating

Overload capacity: 150 % of rating for 10 sec., 110 % continuous

• Current Input

Operational range: 0 - 120 % of rating

Overload capacity: 1000 % of rating for 3 sec., 200 % for 10 sec., 120 % continuous

■ How To Determine Wattage Range

Calibration Range [W] = (Measuring Wattage) ÷ ((VT Ratio) × (CT Ratio))

Check that the required calibration range is within the available range in the table.

[example]

3-phase / 3-wire, measuring wattage 750 kW,

VT 3300 / 110 V, CT 250 / 5 A

$(750 \times 10^3 [W]) \div ((3300 \div 110) \times (250 \div 5)) = 0 - 500 [W]$

■ INPUT RANGE

• 3-phase / 3-wire

INPUT		AVAILABLE RANGE	BURDEN (VA)	
	STD.RANGE		VOLT.	CURR.
110V/1A	±200 W	±100 - ±240 W	P ₁ : 2.5	0.1/ph
110V/5A	±1000 W	±500 - ±1200 W	P ₃ : 0.2	0.5/ph
220V/1A	±400 W	±200 - ±480 W	P ₁ : 2.5	0.1/ph
220V/5A	±2000 W	±1000 - ±2400 W	P ₃ : 0.4	0.5/ph

• Single-phase / 2-wire

INPUT		AVAILABLE RANGE	BURDEN (VA)	
	STD.RANGE		VOLT.	CURR.
110V/1A	±100 W	±50 - ±120 W	2.5	0.1
110V/5A	±500 W	±250 - ±600 W		0.5
220V/1A	±200 W	±100 - ±240 W	2.5	0.1
220V/5A	±1000 W	±500 - ±1200 W		0.5

• Single-phase / 3-wire

INPUT		AVAILABLE RANGE	BURDEN (VA)	
	STD.RANGE		VOLT.	CURR.
200V/1A	±200 W	±100 - ±240 W	P ₁ : 2.5	0.1/ph
200V/5A	±1000 W	±500 - ±1200 W	P ₂ : 0.2	0.5/ph

■ INPUT RANGE

• 3-phase / 4-wire

INPUT		AVAILABLE RANGE	BURDEN (VA)	
	STD.RANGE		VOLT.	CURR.
$\frac{110V}{\sqrt{3}}$ /1A	±200 W	±100 - ±240 W	P ₁ - P ₂ : 2.5	0.1 /phase
$\frac{110V}{\sqrt{3}}$ /5A	±1000 W	±500 - ±1200 W	P ₃ : 0.1	0.5 /phase
$\frac{190V}{\sqrt{3}}$ /1A	±350 W	±175 - ±420 W	P ₁ : 2.5	0.1 /phase
$\frac{190V}{\sqrt{3}}$ /5A	±1750 W	±875 - ±2100 W	P ₂ , P ₃ : 0.2	0.5 /phase
$\frac{220V}{\sqrt{3}}$ /1A	±400 W	±200 - ±480 W	P ₁ - P ₂ : 2.5	0.1 /phase
$\frac{220V}{\sqrt{3}}$ /5A	±2000 W	±1000 - ±2400 W	P ₃ : 0.3	0.5 /phase
$\frac{380V}{\sqrt{3}}$ /1A	±700 W	±350 - ±840 W	P ₁ : 2.5	0.1 /phase
$\frac{380V}{\sqrt{3}}$ /5A	±3500 W	±1750 - ±4200 W	P ₂ , P ₃ : 0.4	0.5 /phase

OUTPUT SPECIFICATIONS

■ DC OUTPUT

• DC Current: 0 - 20 mA DC and ± 1 mA

Minimum span: 1 mA

Offset: Max. 1.5 times span

Load resistance: Output drive 12 V max.

• DC Voltage: -10 - +12 V DC

Minimum span: 5 mV

Offset: Max. 1.5 times span

Load resistance: Output drive 1 mA max. at ≥ 0.5 V

■ Pulse output: Frequency output proportional to the input; 0 - 2.777 Hz typical; 0 Hz at 0 W (cutout at approx. 0.5 - 1.0 %); max. 27.77 Hz at 100 % input

ON duration: 0.025 sec. min.

0.150 sec. min. when the maximum frequency is less than 1 Hz, with the S5 rotary switch set to other than 0.

• **Power Photo MOSFET Relay**

Rating: 120 V AC/DC @ 100 mA (resistive load)

Max. ON resistance: 10 Ω

• **Open Collector**

Rating: 35 V DC @ 100 mA

ON voltage: ≤ 1 V at 100 mA

• **Pulse Unit:** refers to how much electrical energy (kWh) consumption at the primary of the VT and CT corresponds to the single output pulse per hour from the transducer.

• **How to Set Pulse Unit:** The switches S1 through S5, VT and CT ratios, and the transducer's calibration input range all determine the relative value of one pulse, i.e. the number of kWh per pulse.

$$\text{VT Ratio} \times \text{CT Ratio} \times \text{Calibration Range [kW]} \div (2.777 \text{ Hz} \times 3600 \text{ [sec.]} \times 10 \times \text{Pulse Unit [kWh/pulse]}) = 0.XXXX \times 10^{-x}$$

$$= 0. [a1] [a2] [a3] [a4] \times 10^{-[a5]}$$

a1 thr. a4: integer, 1 through 9

a5: integer, 0 through 6

[example] VT 3300 / 110 V, CT 250 / 5 A, Pulse Unit 10

[kWh/pulse], Calibration Range 1000 [W]

$$3300 \div 110 \times 250 \div 5 \times 1 \text{ [kW]} \div (2.777 \text{ Hz} \times 3600 \text{ [sec.]} \times 10 \times 10 \text{ [kWh/pulse]}) = 0.1500 \times 10^{-2}$$

S1 = 1, S2 = 5, S3 = 0, S4 = 0, S5 = 2

■ **OPERATION DIAGRAM (example)**

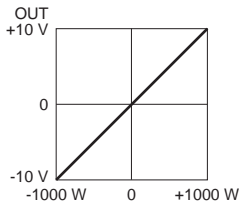
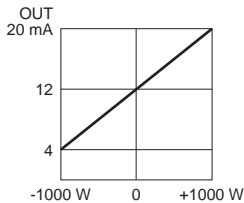
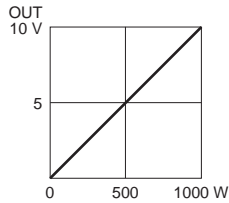
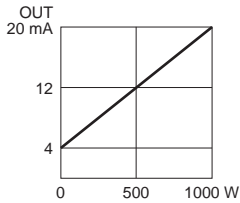

INSTALLATION

Operating temperature: -10 to +55°C (14 to 131°F)

Operating humidity: 30 to 85 %RH (non-condensing)

Mounting: Surface or DIN rail

Weight: 550 g (1.21 lb)

PERFORMANCE in percentage of span

Accuracy: ±0.5 % (at 23°C ±10°C or 73.4°F ±18°F, 45 - 65 Hz)

Response time: ≤ 2 sec. (0 - 100 % ±1 %)

Ripple: 0.5 %p-p max.

Insulation resistance: ≥ 100 MΩ with 500 V DC

Dielectric strength: 2000 V AC @ 1 minute

(voltage input to current input to DC output to ground)

1000 V AC @ 1 minute

(pulse output to voltage input or current input or DC output or ground)

Impulse withstand voltage: 1.2 / 50 μsec., ±5 kV

(input to output or ground)

EXTERNAL VIEW

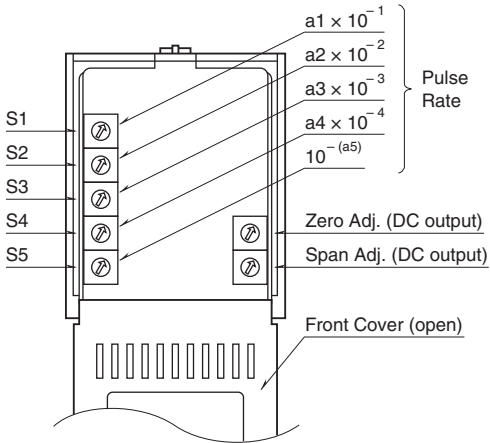

CONNECTION DIAGRAM

■ 3-PHASE/3-WIRE

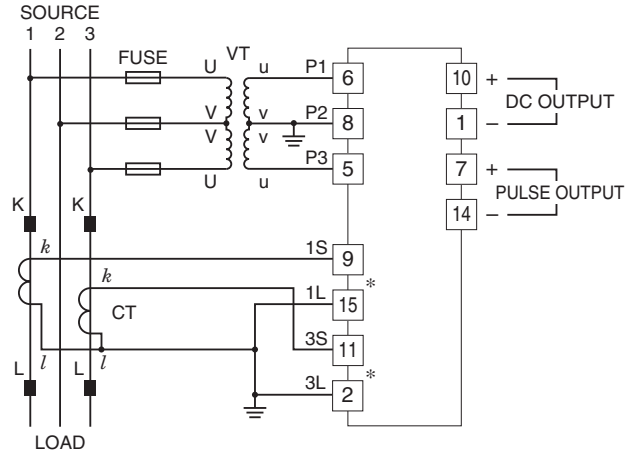

■ SINGLE-PHASE/2-WIRE

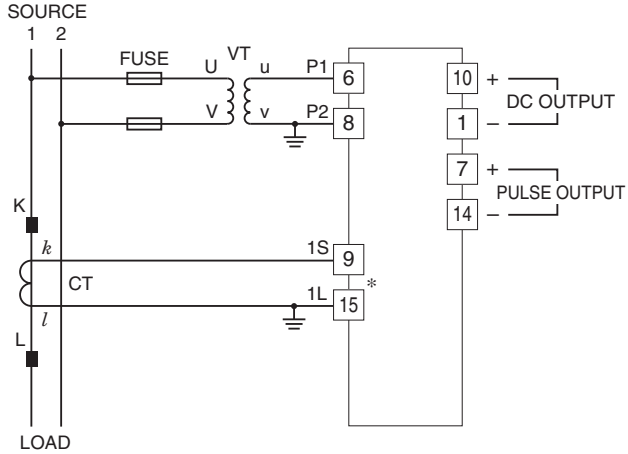

■ SINGLE-PHASE/3-WIRE

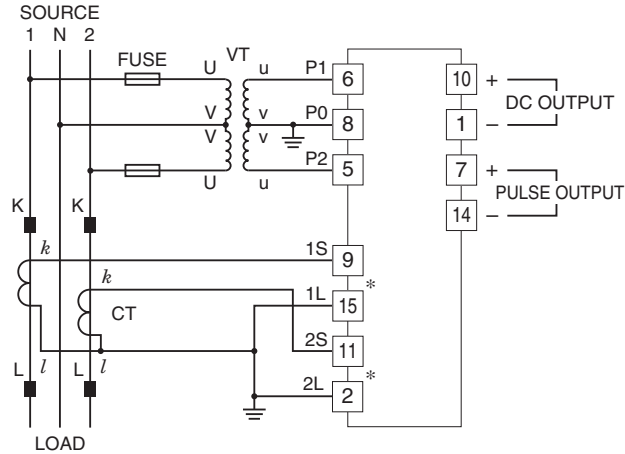

*CT Protector (model: CTM) attached to these terminals.

■ 3-PHASE/4-WIRE

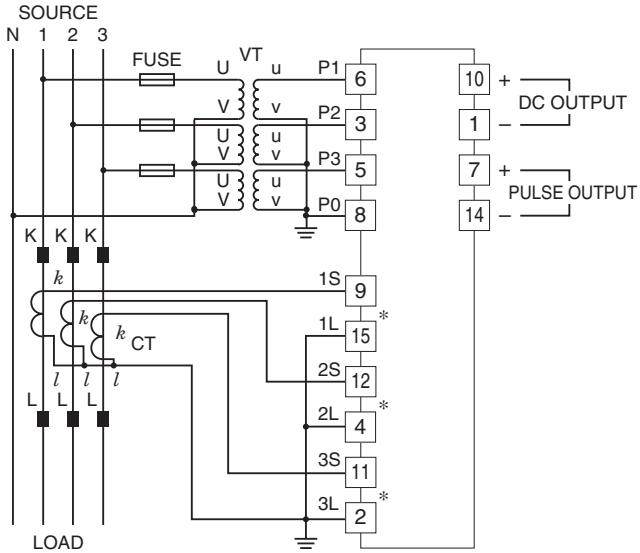

Pulse Output Connection Examples

■ Open Collector

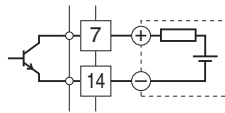

■ Power Photo MOSFET Relay

• AC Powered

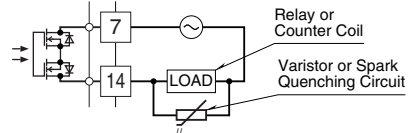

• DC Powered

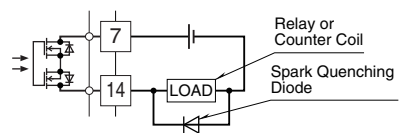

EXTERNAL DIMENSIONS & TERMINAL ASSIGNMENTS unit: mm [inch]

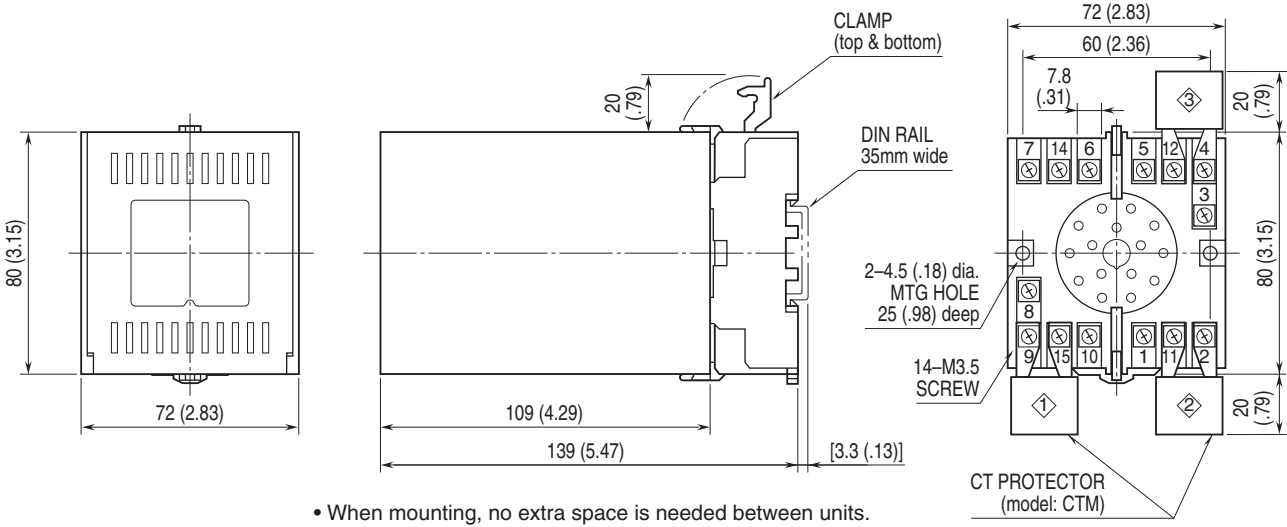

• When mounting, no extra space is needed between units.

- Positions of CTM
- ◇ KUWTN-2
 - ◇◇ KUWTN-1, -3
 - ◇◇◇ KUWTN-4

 Specifications are subject to change without notice.