

Plug-in Signal Conditioners K-UNIT

WATT TRANSDUCER

(with pulse output)

Functions & Features

- Providing a DC output signal and pulse totalizer signal in proportion to AC active power
- Convenient pulse unit output (Wh×10ⁿ)
- Measuring bidirectional power flow
- DC output containing little ripple is ideal for computer input
- "Time division multiplication" method accepts distorted waveforms
- High-density mounting

Typical Applications

- Centralized monitoring and control of power management system in a manufacturing facility or building
- SCR – Silicon Controlled Rectifier

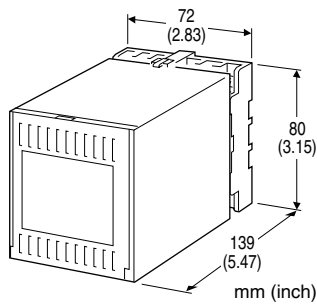

MODEL: KUWT-[1][2][3][4]-[5][6]

ORDERING INFORMATION

- Code number: KUWT-[1][2][3][4]-[5][6]
- Specify a code from below for each of [1] through [6]. (e.g. KUWT-11A4-C/Q)
- Calibration range (e.g. -750 – +750 W)
- VT ratio, CT ratio (e.g. VT 3300 / 110 V, CT 250 / 5 A)
- Special DC output range (For codes Z & 0)
- Pulse output (e.g. 6.666 Wh/pulse)
- Specify the specification for option code /Q (e.g. /C01/S01)

How To Determine Pulse Unit

[example]

3-phase / 3-wire, VT 3300 / 110 V, CT 250 / 5 A, calibration range 750 W

• **From Pulse Unit** 10 [kWh/pulse]
 $10 \text{ [kWh/pulse]} \div ((3300 \div 110) \times (250 \div 5)) = 6.666 \times 10^{-3} \text{ [kWh/pulse]}$

= 6.666 [Wh/pulse]

- **From Pulse Rate** 150 [pulse/kWh]

$1 \div 150 \text{ [pulse/kWh]}$

= $6.666 \times 10^{-3} \text{ [kWh/pulse]}$

= 6.666 [Wh/pulse]

- **From Frequency** 0.03125 Hz (at 100 %)

$750 \text{ [W]} \div (0.03125 \text{ [Hz]} \times 3600 \text{ [sec.]}) = 6.666 \text{ [Wh/pulse]}$

[1] CONFIGURATION

- 1: 3-phase / 3-wire
- 2: Single-phase / 2-wire
- 3: Single-phase / 3-wire

[2] INPUT (unbalanced load)

- 1: 110 V / 5 A AC
- 2: 110 V / 1 A AC
- 3: 220 V / 1 A AC
- 4: 220 V / 5 A AC
- A: 100 V / 200 V / 1 A AC (single-phase / 3- wire)
- B: 100 V / 200 V / 5 A AC (single-phase / 3- wire)

[3] DC OUTPUT

Current

- A: 4 – 20 mA DC (Load resistance 600 Ω max.)
- B: 2 – 10 mA DC (Load resistance 1200 Ω max.)
- C: 1 – 5 mA DC (Load resistance 2400 Ω max.)
- D: 0 – 20 mA DC (Load resistance 600 Ω max.)
- E: 0 – 16 mA DC (Load resistance 750 Ω max.)
- F: 0 – 10 mA DC (Load resistance 1200 Ω max.)
- G: 0 – 1 mA DC (Load resistance 12 kΩ max.)
- J: 0 – 5 mA DC (Load resistance 2400 Ω max.)
- GW: -1 – +1 mA DC (Load resistance 10 kΩ max.)
- Z: Specify current (See OUTPUT SPECIFICATIONS)

Voltage

- 1: 0 – 10 mV DC (Load resistance 10 kΩ min.)
- 2: 0 – 100 mV DC (Load resistance 100 kΩ min.)
- 3: 0 – 1 V DC (Load resistance 1000 Ω min.)
- 4: 0 – 10 V DC (Load resistance 10 kΩ min.)
- 5: 0 – 5 V DC (Load resistance 5000 Ω min.)
- 6: 1 – 5 V DC (Load resistance 5000 Ω min.)
- 1W: -10 – +10 mV DC (Load resistance 10 kΩ min.)
- 2W: -100 – +100 mV DC (Load resistance 100 kΩ min.)
- 3W: -1 – +1 V DC (Load resistance 1000 Ω min.)
- 4W: -10 – +10 V DC (Load resistance 10 kΩ min.)
- 5W: -5 – +5 V DC (Load resistance 5000 Ω min.)
- 0: Specify voltage (See OUTPUT SPECIFICATIONS)

[4] PULSE OUTPUT

- 2: Open collector
- 3: Relay contact (mercury relay)

Suffix code 3 has been discontinued. Select code 4 instead.

4: Power photo MOSFET relay

[5] AUXILIARY POWER SUPPLY

AC Power

B: 100 V AC

C: 110 V AC

D: 115 V AC

F: 120 V AC

G: 200 V AC

H: 220 V AC

J: 240 V AC

DC Power

R: 24 V DC

V: 48 V DC

P: 110 V DC

[6] OPTIONS

blank: none

/Q: With options (specify the specification)

SPECIFICATIONS OF OPTION: Q (multiple selections)

COATING (For the detail, refer to our web site.)

/C01: Silicone coating

/C02: Polyurethane coating

/C03: Rubber coating

TERMINAL SCREW MATERIAL

/S01: Stainless steel

GENERAL SPECIFICATIONS

Construction: Plug-in

Connection: M3.5 screw terminals

Screw terminal: Chromated steel (standard) or stainless steel

Housing material: Flame-resistant resin (black)

Isolation: Voltage input to current input to DC output to pulse output to auxiliary power

Computation: Time division multiplication

Overrange output: Approx. -10 - +120 % at 1 - 5 V

Zero adjustment(DC output): -5 to + 5 % (front)

Span adjustment(DC output): 95 to + 105 % (front)

INPUT SPECIFICATIONS

Frequency: 50 or 60 Hz

• Voltage Input

Operational range: 0 - 120 % of rating

Overload capacity: 150 % of rating for 10 sec., 120 % continuous

• Current Input

Operational range: 0 - 120 % of rating

Overload capacity: 1000 % of rating for 3 sec., 200 % for 10 sec., 120% continuous

How To Determine Wattage Range

Calibration Range [W] = (Measuring Wattage) ÷ ((VT Ratio) × (CT Ratio))

Check that the required calibration range is within the available range in the table.

[example]

3-phase / 3-wire, measuring wattage 750 kW,

VT 3300 / 110 V, CT 250 / 5 A

$(750 \times 10^3 [W]) \div ((3300 \div 110) \times (250 \div 5)) = 0 - 500 [W]$

INPUT RANGE

• 3-phase / 3-wire

INPUT		AVAILABLE RANGE	BURDEN (VA)	
	STD.RANGE		VOLT.	CURR.
110V/1A	±200 W	±100 - ±240 W	0.2	0.1/ph
110V/5A	±1000 W	±500 - ±1200 W	/phase	0.5/ph
220V/1A	±400 W	±200 - ±480 W	0.4	0.1/ph
220V/5A	±2000 W	±1000 - ±2400 W	/phase	0.5/ph

• Single-phase / 2-wire

INPUT		AVAILABLE RANGE	BURDEN (VA)	
	STD.RANGE		VOLT.	CURR.
110V/1A	±100 W	±50 - ±120 W	0.2	0.1
110V/5A	±500 W	±250 - ±600 W		0.5
220V/1A	±200 W	±100 - ±240 W	0.4	0.1
220V/5A	±1000 W	±500 - ±1200 W		0.5

• Single-phase / 3-wire

INPUT		AVAILABLE RANGE	BURDEN (VA)	
	STD.RANGE		VOLT.	CURR.
200V/1A	±200 W	±100 - ±240 W	0.2	0.1/ph
200V/5A	±1000 W	±500 - ±1200 W	/phase	0.5/ph

OUTPUT SPECIFICATIONS

DC OUTPUT

• DC Current: 0 - 20 mA DC and ± 1 mA

Minimum span: 1 mA

Offset: Max. 1.5 times span

Load resistance: Output drive 12 V max.

• DC Voltage: -10 - +12 V DC

Minimum span: 5 mV

Offset: Max. 1.5 times span

Load resistance: Output drive 1 mA max. at ≥ 0.5 V

■ Pulse output: Frequency output proportional to the input; 0 - 2.777 Hz typical; 0 Hz at 0 W (cutout at approx. 0.5 - 1.0 %); max. 27.77 Hz at 100 % input

ON duration: 0.025 sec. min.

0.150 sec. min. when the maximum frequency is less than 1 Hz, with the S5 rotary switch set to other than 0.

• Power Photo MOSFET Relay

Rating: 120 V AC/DC @ 100 mA (resistive load)

Max. ON resistance: 10 Ω

• Open Collector

Rating: 35 V DC @ 100 mA

ON voltage: ≤ 1 V at 100 mA

- **Pulse Unit:** refers to how much electrical energy (kWh) consumption at the primary of the VT and CT corresponds to the single output pulse per hour from the transducer.

- **How to Set Pulse Unit:** The switches S1 through S5, VT and CT ratios, and the transducer's calibration input range all determine the relative value of one pulse, i.e. the number of kWh per pulse.

VT Ratio \times CT Ratio \times Calibration Range [kW] \div (2.777 Hz \times 3600 [sec.] \times 10 \times Pulse Unit [kWh/pulse])

= 0.XXXX $\times 10^{-x}$

= 0. [a1] [a2] [a3] [a4] $\times 10^{-[a5]}$

a1 thr. a4: integer, 1 though 9

a5: integer, 0 through 6

[example] VT 3300 / 110 V, CT 250 / 5 A, Pulse Unit 10

[kWh/pulse], Calibration Range 1000 [W]

3300 \div 110 \times 250 \div 5 \times 1 [kW] \div (2.777 Hz \times 3600 [sec.]

\times 10 \times 10 [kWh/pulse]) = 0.1500 $\times 10^{-2}$

S1 = 1, S2 = 5, S3 = 0, S4 = 0, S5 = 2

■ OPERATION DIAGRAM (example)

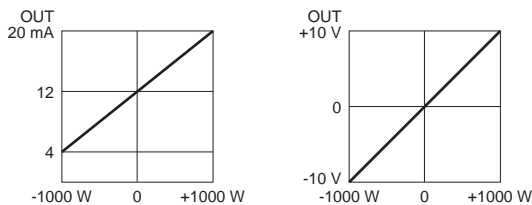
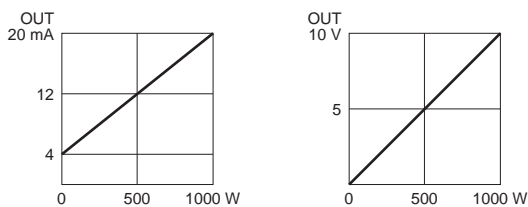

Ripple: 0.5 %p-p max. (The output ripple may increase when there is great difference between the frequencies of input signal and power supply)

Line voltage effect: ± 0.1 % over voltage range

Insulation resistance: ≥ 100 M Ω with 500 V DC

Dielectric strength: 2000 V AC @ 1 minute

(voltage input to current input to DC output to power to ground)

1000 V AC @ 1 minute

(pulse output to voltage input or current input or DC output or power or ground)

Impulse withstand voltage: 1.2 / 50 μ sec., ± 5 kV

(input to output or ground)

INSTALLATION

Auxiliary power supply

- **AC:** Operational voltage range: rating $-15/+10$ %, 50/60 Hz, approx. 2 VA

- **DC:** Operational voltage range: rating ± 10 %, or 85 - 150 V for 110 V rating, ripple 10 %p-p max., approx. 2 W (18 mA at 110 V)

Operating temperature: -10 to $+55^\circ\text{C}$ (14 to 131°F)

Operating humidity: 30 to 85 %RH (non-condensing)

Mounting: Surface or DIN rail

Weight: 550 g (1.21 lb)

PERFORMANCE in percentage of span

Accuracy: ± 0.5 % (at $23^\circ\text{C} \pm 10^\circ\text{C}$ or $73.4^\circ\text{F} \pm 18^\circ\text{F}$, 45 - 65 Hz)

Response time: ≤ 2 sec. (0 - 100 % ± 1 %)

EXTERNAL VIEW

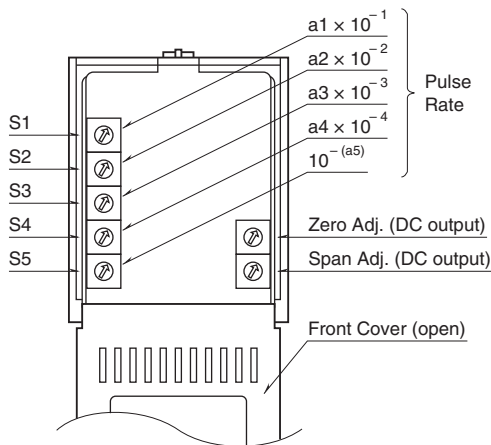

CONNECTION DIAGRAM

3-PHASE/3-WIRE

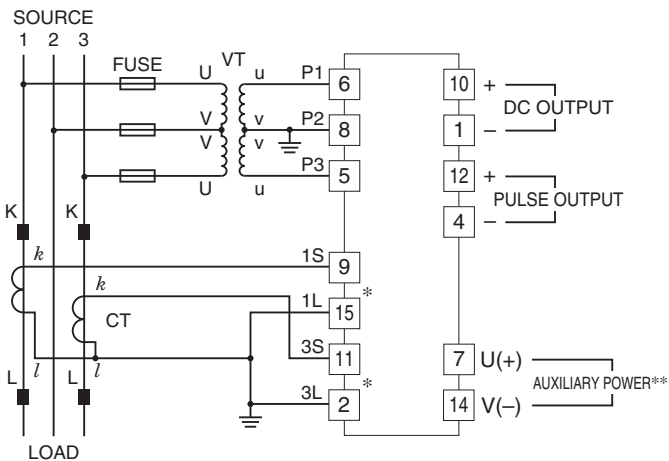

SINGLE-PHASE/2-WIRE

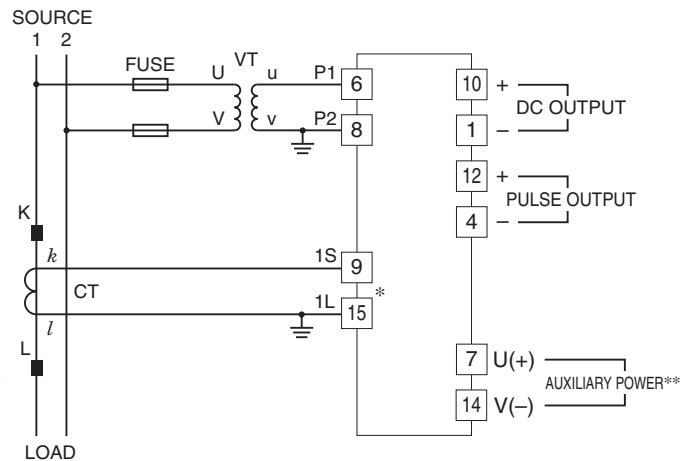

SINGLE-PHASE/3-WIRE

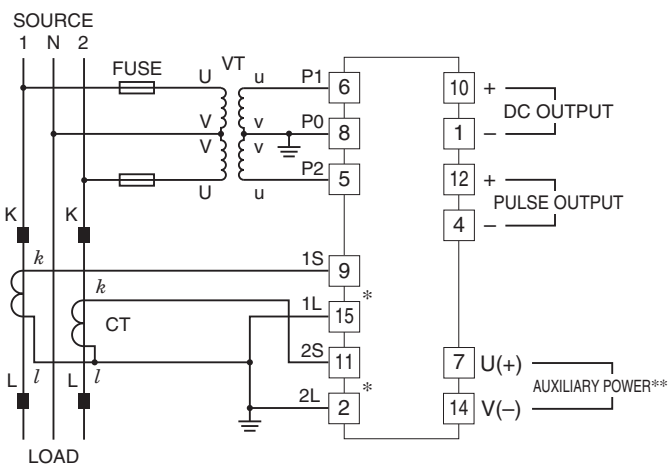

Pulse Output Connection Examples

Open Collector

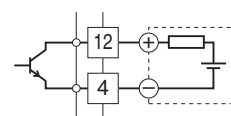

Power Photo MOSFET Relay

AC Powered

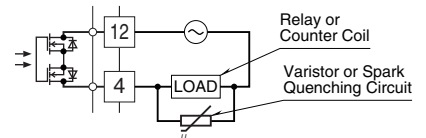

DC Powered

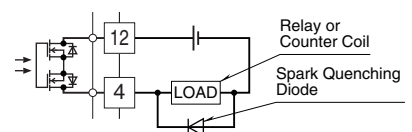

*CT Protector (model: CTM) attached to these terminals.

**The transducer can be powered from the input voltage when the voltage is sufficiently stable and meets within the range of auxiliary power supply of the unit specified in the data sheet/instruction manual.

EXTERNAL DIMENSIONS & TERMINAL ASSIGNMENTS unit: mm [inch]

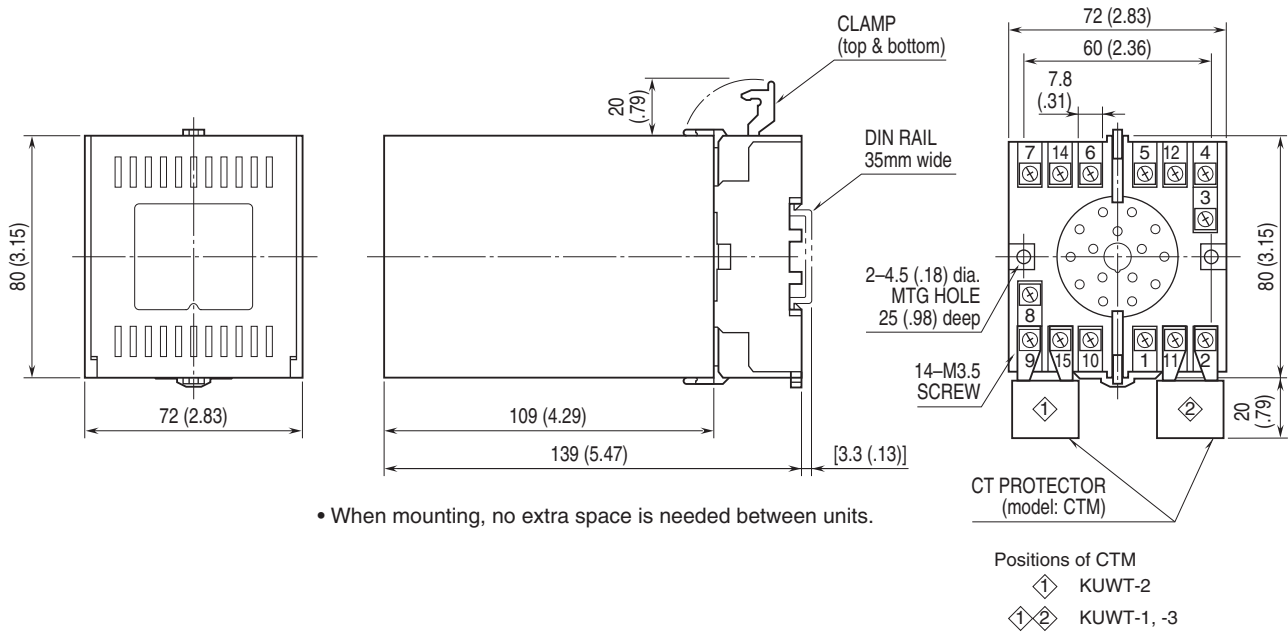

Specifications are subject to change without notice.