

CURRENT LOOP SUPPLY
(for level transmitter use)

MODEL **KWLD**

BEFORE USE

Thank you for choosing M-System. Before use, please check contents of the package you received as outlined below. If you have any problems or questions with the product, please contact M-System's Sales Office or representatives.

■ **PACKAGE INCLUDES:**

Signal conditioner (body + base socket).....(1)

■ **MODEL NO.**

Confirm Model No. marking on the product to be exactly what you ordered.

■ **INSTRUCTION MANUAL**

This manual describes necessary points of caution when you use this product, including installation, connection and basic maintenance procedures.

POINTS OF CAUTION

■ **POWER INPUT RATING & OPERATIONAL RANGE**

- Locate the power input rating marked on the product and confirm its operational range as indicated below:
AC power: Rating ±10%, 50/60 ±2 Hz, approx. 3.5VA
DC power: Rating ±10%, approx. 3W

■ **GENERAL PRECAUTIONS**

- Before you remove the unit from its base socket or mount it, turn off the power supply and input signal for safety.

■ **ENVIRONMENT**

- Indoor use.
- When heavy dust or metal particles are present in the air, install the unit inside proper housing with sufficient ventilation.
- Do not install the unit where it is subjected to continuous vibration. Do not subject the unit to physical impact.
- Environmental temperature must be within -5 to +55°C (23 to 131°F) with relative humidity within 30 to 90% RH in order to ensure adequate life span and operation.

■ **WIRING**

- Do not install cables close to noise sources (relay drive cable, high frequency line, etc.).
- Do not bind these cables together with those in which noises are present. Do not install them in the same duct.

■ **AND**

- When the startup current for the level transmitter is high, the KWLD may not start. In such a case, maintain the power supply and turn the Loop Test SW off once and on again.
- The unit is designed to function as soon as power is supplied, however, a warm up for 10 minutes is required for satisfying complete performance described in the data sheet.

COMPONENT IDENTIFICATION

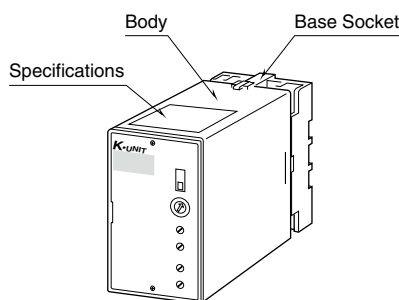

INSTALLATION

Detach the yellow clamps located at the top and bottom of the unit for separate the body from the base socket.

■ **DIN RAIL MOUNTING**

Set the base socket so that its DIN rail adaptor is at the bottom. Position the upper hook at the rear side of base socket on the DIN rail and push in the lower. When removing the socket, push down the DIN rail adaptor utilizing a minus screwdriver and pull.

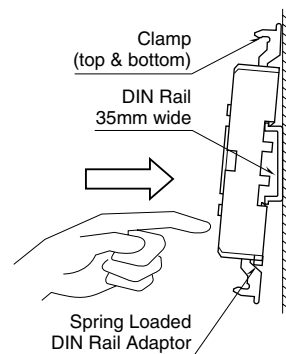

■ **WALL MOUNTING**

Refer to "EXTERNAL DIMENSIONS."

Shape and size of the base socket are slightly different with various socket types.

TERMINAL CONNECTIONS

Connect the unit as in the diagram below or refer to the connection diagram on the front of the unit.

EXTERNAL DIMENSIONS unit: mm (inch)

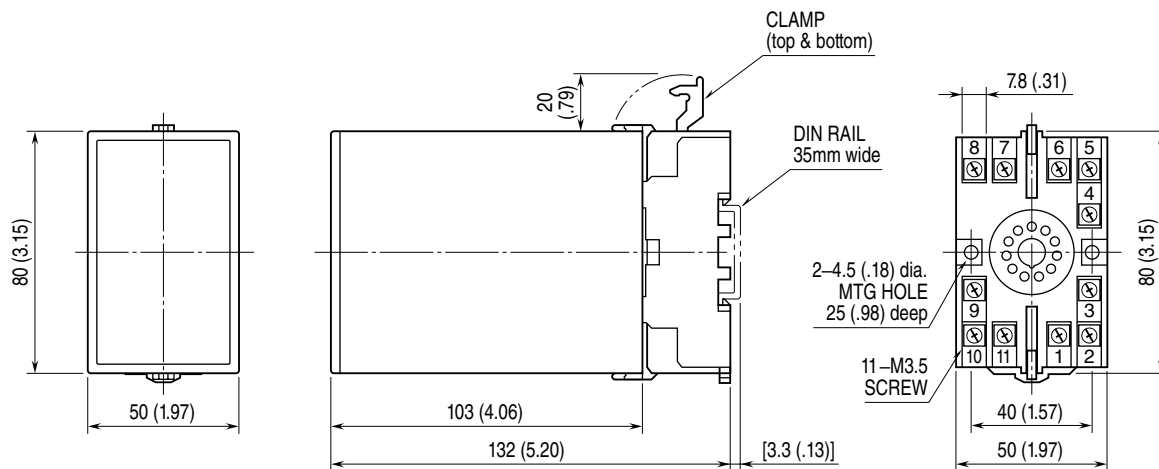

• When mounting, no extra space is needed between units.

CONNECTION DIAGRAM

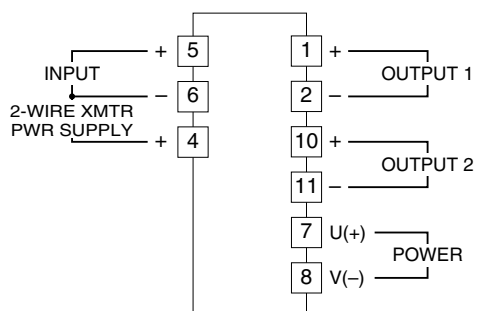

When Used as DC Supply

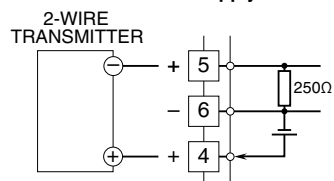

When Used as Isolator

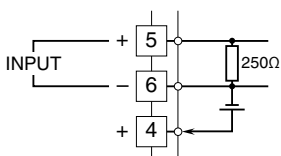

CHECKING

- 1) Terminal wiring: Check that all cables are correctly connected according to the connection diagram.
- 2) Power input voltage: Check voltage across the terminal 7 – 8 with a multimeter.
- 3) Input: Check that the input signal is within 0 – 100% of the full-scale.
- 4) Output: Check that the load resistance meets the described specifications.

When using a signal generator to simulate the input signal, the supply output may be turned off with the Loop Test SW.

ADJUSTMENT PROCEDURE

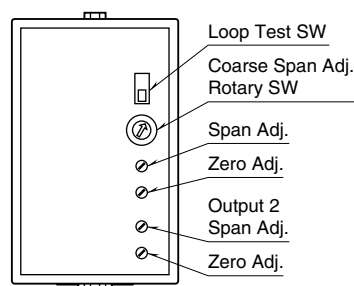

• Loop Test SW (LOOP POWER)

Can turn off the power supply of 2-WIRE XMTR. Sliding the switch up sets the power supply to ON, sliding down sets to OFF.

• Coarse Span Adj. Rotary SW (COARSE SPAN)

Used to coarsely scale input signal (4 to 20 mA DC) from 10 to 100 % in 16 steps (unequal steps).

Apply the appropriate input signal and adjust coarsely OUTPUT 1 signal to approx. 100% with COARSE SPAN.

• Span Adj. (SPAN)

After adjustment with COARSE SPAN, adjust OUTPUT 1 signal to 100% with SPAN (As this adjustment influences OUTPUT 2, adjust OUTPUT 2 with OUTPUT 2 SPAN.).

• Zero Adj. (ZERO)

Used to adjust OUTPUT signal to 0% (As this adjustment influences OUTPUT 2, adjust OUTPUT 2 with OUTPUT 2 ZERO.).

• OUTPUT 2 SPAN Adj. (OUT 2 SPAN)

After SPAN adjustment, adjust OUTPUT 2 signal to 100% with OUT 2 SPAN.

• OUTPUT 2 ZERO Adj. (OUT 2 ZERO)

After ZERO adjustment, adjust OUTPUT 2 signal to 0% with OUT 2 ZERO.

[Adjustment example]

With a water-level gauge ranging from 0 to 10 m, the procedure to output 4 to 20 mA DC for 0 to 5 m is as follows.

- 1) Apply 0% input and adjust OUTPUT 1 to 0% with ZERO. Then adjust OUTPUT 2 with OUT 2 ZERO.
- 2) Apply 50% input and adjust OUTPUT 1 to approx. 100% with COARSE SPAN.
- 3) Adjust OUTPUT 1 to 100% with SPAN. Then adjust OUTPUT 2 with OUT 2 SPAN.
- 4) Apply 0% input again and check zero output.
- 5) When zero output deviates, repeat the above procedure 1) – 4).

MAINTENANCE

Regular calibration procedure is explained below:

■ CALIBRATION

Warm up the unit for at least 10 minutes. Apply 0%, 25%, 50%, 75% and 100% input signal. Check that the output signal for the respective input signal remains within accuracy described in the data sheet. When the output is out of tolerance, recalibrate the unit according to the “ADJUSTMENT PROCEDURE” explained earlier.

LIGHTNING SURGE PROTECTION

M-System offers a series of lightning surge protector for protection against induced lightning surges. Please contact M-System to choose appropriate models.