

<b>WATT TRANSDUCER</b> (with pulse output)	MODEL <b>KUWT</b>
---	-------------------

**BEFORE USE ....**

Thank you for choosing us. Before use, please check contents of the package you received as outlined below. If you have any problems or questions with the product, please contact our sales office or representatives.

**PACKAGE INCLUDES:**

Signal conditioner  
(body + base socket + CT protector) .....(1)

**MODEL NO.**

Confirm Model No. marking on the product to be exactly what you ordered.

**INSTRUCTION MANUAL**

This manual describes necessary points of caution when you use this product, including installation, connection and basic maintenance procedures.

**POINTS OF CAUTION**

**AUXILIARY POWER INPUT RATING & OPERATIONAL RANGE**

- Locate the auxiliary power input rating marked on the product and confirm its operational range as indicated below:
  - AC power:** Rating -15/+10%, 50/60 Hz, approx. 2VA
  - DC power:** Rating ±10%, approx. 2W  
or 85 – 150V, approx. 2W for 110V rating

**GENERAL PRECAUTIONS**

- Before you remove the unit from its base socket or mount it, turn off the power supply and input signal for safety.

**CT PROTECTOR**

- Temperature of the CT Protector may rise if the signal conditioner body is left unplugged from the base socket. Be careful not to get burned when you need to touch it.

**ENVIRONMENT**

- Indoor use.
- When heavy dust or metal particles are present in the air, install the unit inside proper housing with sufficient ventilation.
- Do not install the unit where it is subjected to continuous vibration. Do not subject the unit to physical impact.
- Environmental temperature must be within -10 to +55°C (14 to 131°F) with relative humidity within 30 to 85% RH in order to ensure adequate life span and operation.

**WIRING**

- Do not install cables close to noise sources (relay drive cable, high frequency line, etc.).
- Do not bind these cables together with those in which noises are present. Do not install them in the same duct.

**AND ....**

- The unit is designed to function as soon as power is supplied, however, a warm up for 10 minutes is required for satisfying complete performance described in the data sheet.

**COMPONENT IDENTIFICATION**

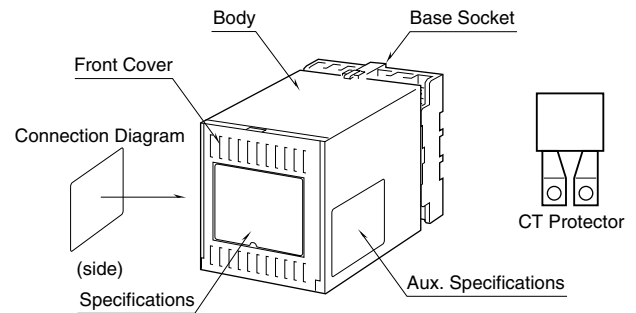

**HOW TO OPEN THE FRONT COVER:**

Hang your finger on the hook at the top of the front cover and pull.

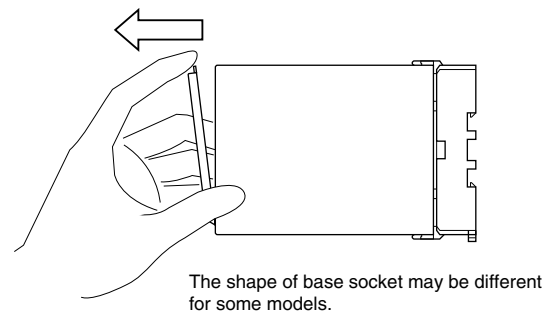

**FRONT PANEL CONFIGURATIONS**

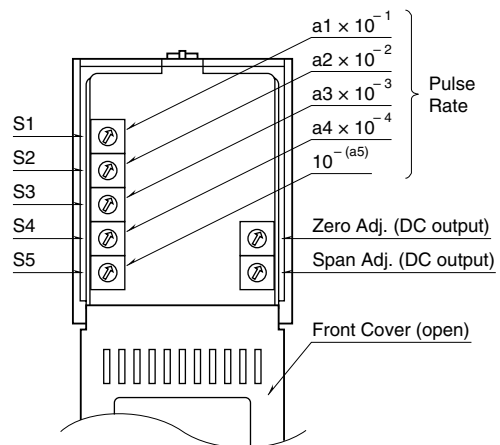

## INSTALLATION

Detach the yellow clamps located at the top and bottom of the unit for separate the body from the base socket.

### ■ DIN RAIL MOUNTING

Set the base socket so that its DIN rail adaptor is at the bottom. Hang the upper hook at the rear side of base socket on the DIN rail and push in the lower. When removing the socket, push down the DIN rail adaptor utilizing a minus screwdriver and pull.

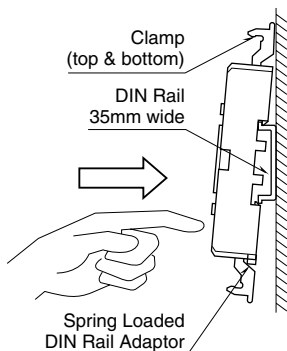

### ■ WALL MOUNTING

Refer to “EXTERNAL DIMENSIONS.”

Shape and size of the base socket are slightly different with various socket types.

## TERMINAL CONNECTIONS

Connect the unit as in the diagram below or refer to the connection diagram on the side of the unit. Attach the CT Protector together with input wiring to the input screw terminals.

### ■ EXTERNAL DIMENSIONS unit: mm (inch)

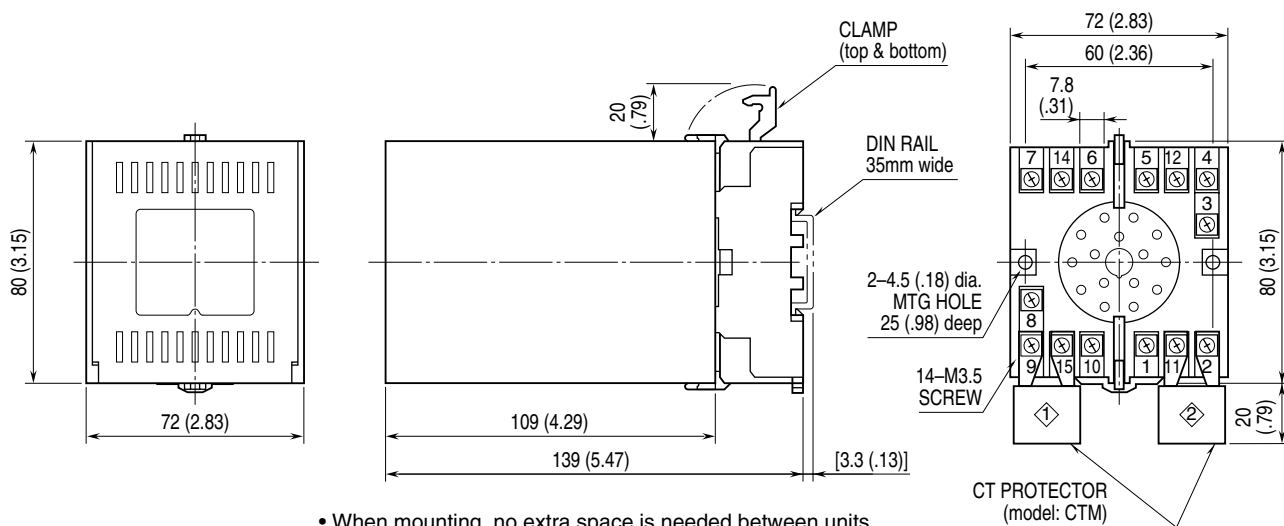

Positions of CTM  
 ◆ KUWT-2  
 ◆ KUWT-1, -3

■ CONNECTION DIAGRAM

■ 3-PHASE/3-WIRE

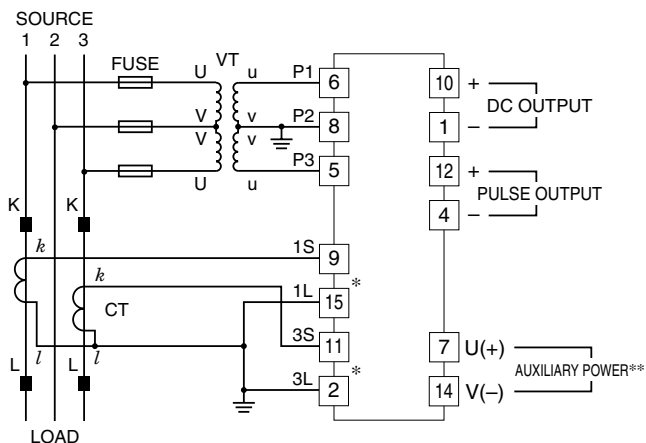

■ SINGLE-PHASE/2-WIRE

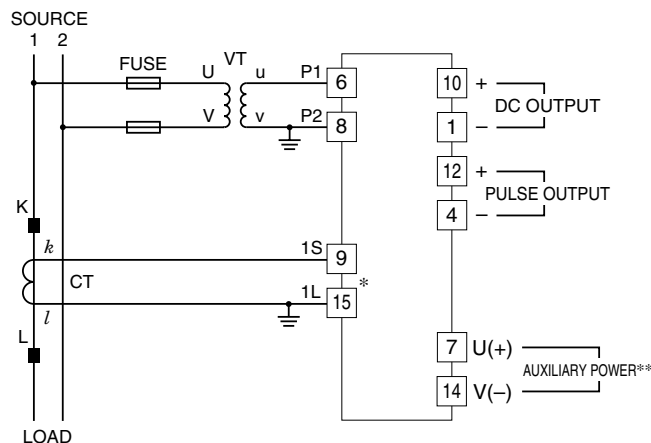

■ SINGLE-PHASE/3-WIRE

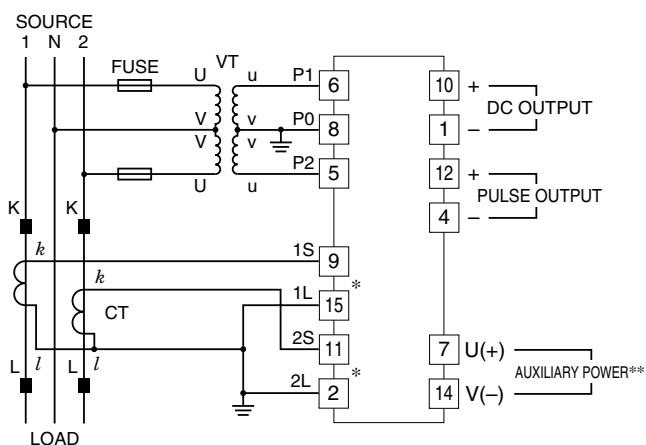

Pulse Output Connection Examples

■ Open Collector

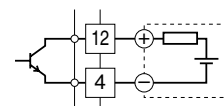

■ Power Photo MOSFET Relay

• AC Powered

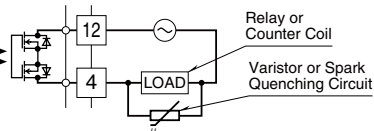

• DC Powered

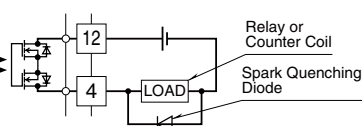

\*CT Protector (model: CTM) attached to these terminals.

\*\*The transducer can be powered from the input voltage when the voltage is sufficiently stable and meets within the range of auxiliary power supply of the unit specified in the data sheet/instruction manual.

## CHECKING

- 1) Terminal wiring: Check that all cables are correctly connected according to the connection diagram.
- 2) Auxiliary power input voltage: Check voltage across the terminal 7 – 14 with a multimeter.
- 3) Input: Calculate the calibration range and check that the result is within the usable range.

$$\text{Calibration Range [W]} = \frac{\text{Measuring Wattage}}{(\text{VT Ratio}) \times (\text{CT Ratio})}$$

- 4) DC output: Check that the load resistance meets the described specifications.
- 5) Integrating pulse output: Check the load connected to the pulse output:

Open collector: 35V DC @100mA

Power photo MOSFET relay: 120V AC/DC @100mA

## ADJUSTMENTS PROCEDURE

This unit is calibrated at the factory to meet the ordered specifications, therefore you usually do not need any calibration.

For matching the signal to a receiving instrument or in case of regular calibration, adjust the output as explained in the following.

### ■ HOW TO CALIBRATE THE DC OUTPUT SIGNAL

Use a signal source and measuring instruments of sufficient accuracy level. Turn the auxiliary power supply on and warm up for more than 10 minutes.

- 1) ZERO: Apply 0% input and adjust output to 0%.
- 2) SPAN: Apply 100% input and adjust output to 100%.
- 3) Check ZERO adjustment again with 0% input.
- 4) When ZERO value is changed, repeat the above procedure 1) – 3).

### ■ HOW TO SET THE PULSE UNIT

The switches S1 through S5, VT and CT ratios, and the transducer's calibration input range all determine the relative value of one pulse, i.e. the number of kWh per pulse.

$$\begin{aligned} & \frac{\text{VT Ratio} \times \text{CT Ratio} \times \text{Calibration Range [kW]}}{2.777 \text{ Hz} \times 3600 \text{ [sec.]} \times 10 \times \text{Pulse Unit [kWh/pulse]}} \\ & = 0.\text{XXXX} \times 10^{-x} \\ & = 0. [\text{a1}] [\text{a2}] [\text{a3}] [\text{a4}] \times 10^{-[\text{a5}]} \\ & \quad \text{a1 through a4: integer, 1 through 9} \\ & \quad \text{a5: integer, 0 through 6} \end{aligned}$$

**[example]** VT 3300V / 110V, CT 250A / 5A, Pulse Unit 10 [kWh/pulse], Calibration Range 1000 [W]

$$\begin{aligned} & \frac{3300 / 110 \times 250 / 5 \times 1 \text{ [kW]}}{2.777 \text{ Hz} \times 3600 \text{ [sec.]} \times 10 \times 10 \text{ [kWh/pulse]}} \\ & = 0.1500 \times 10^{-2} \end{aligned}$$

S1 = 1, S2 = 5, S3 = 0, S4 = 0, S5 = 2

## MAINTENANCE

Regular calibration procedure is explained below:

### ■ CALIBRATION

Warm up the unit for at least 10 minutes. Apply 0%, 25%, 50%, 75% and 100% input signal. Check that the output signal for the respective input signal remains within accuracy described in the data sheet. When the output is out of tolerance, recalibrate the unit according to the "ADJUSTMENT PROCEDURE" explained earlier.

## LIGHTNING SURGE PROTECTION

We offer a series of lightning surge protector for protection against induced lightning surges. Please contact us to choose appropriate models.