

THERMOCOUPLE TRANSMITTER
(field-programmable)

MODEL

HJT

BEFORE USE

Thank you for choosing us. Before use, please check contents of the package you received as outlined below. If you have any problems or questions with the product, please contact our sales office or representatives.

■ **PACKAGE INCLUDES:**

Signal conditioner (body + base socket + CJC sensor).....(1)

■ **MODEL NO.**

Confirm Model No. marking on the product to be exactly what you ordered.

■ **INSTRUCTION MANUAL**

This manual describes necessary points of caution when you use this product, including installation, connection, hardware setting and basic maintenance procedures. When you need to change software settings, please refer to the Operation Manual for Model PU-2x (EM-9255), Section A.

POINTS OF CAUTION

■ **POWER INPUT RATING & OPERATIONAL RANGE**

- Locate the power input rating marked on the product and confirm its operational range as indicated below:
24V DC rating: 24V ±10%, approx. 90mA

■ **GENERAL PRECAUTIONS**

- Before you remove the unit from its base socket or mount it, turn off the power supply and input signal for safety.

■ **ENVIRONMENT**

- Indoor use.
- When heavy dust or metal particles are present in the air, install the unit inside proper housing with sufficient ventilation.
- Do not install the unit where it is subjected to continuous vibration. Do not subject the unit to physical impact.
- Environmental temperature must be within -5 to +55°C (23 to 131°F) with relative humidity within 30 to 90% RH in order to ensure adequate life span and operation.

■ **WIRING**

- Do not install cables close to noise sources (relay drive cable, high frequency line, etc.).
- Do not bind these cables together with those in which noises are present. Do not install them in the same duct.

■ **AND**

- The unit is designed to function as soon as power is supplied, however, a warm up for 10 minutes is required for satisfying complete performance described in the data sheet.

COMPONENT IDENTIFICATION

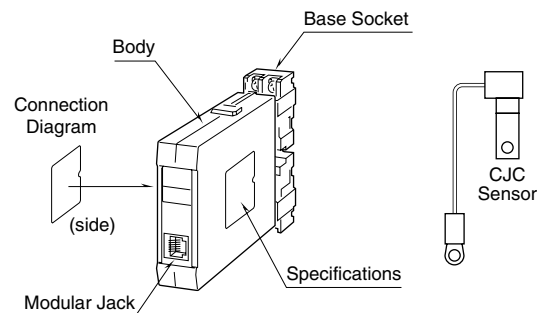

INSTALLATION

Pull out the body in pressing the clamps located at the top and bottom of the unit for separate the body from the base socket.

■ **DIN RAIL MOUNTING**

Set the base socket so that its DIN rail adaptor is at the bottom. Hang the upper hook at the rear side of base socket on the DIN rail and push in the lower. When removing the socket, push down the DIN rail adaptor utilizing a minus screwdriver and pull.

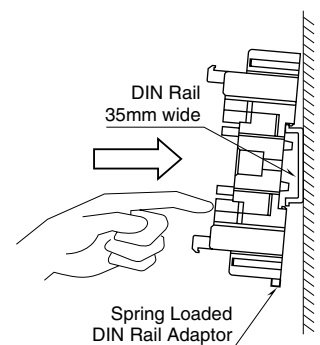

■ **WALL MOUNTING**

Refer to "EXTERNAL DIMENSIONS."

TERMINAL CONNECTIONS

Connect the unit as in the diagram below or refer to the connection diagram on the side of the unit.

Attach the CJC sensor together with input wiring to the input terminals. The CJC sensor is not interchangeable. Check that its serial number is identical to that of the unit.

EXTERNAL DIMENSIONS unit: mm (inch)

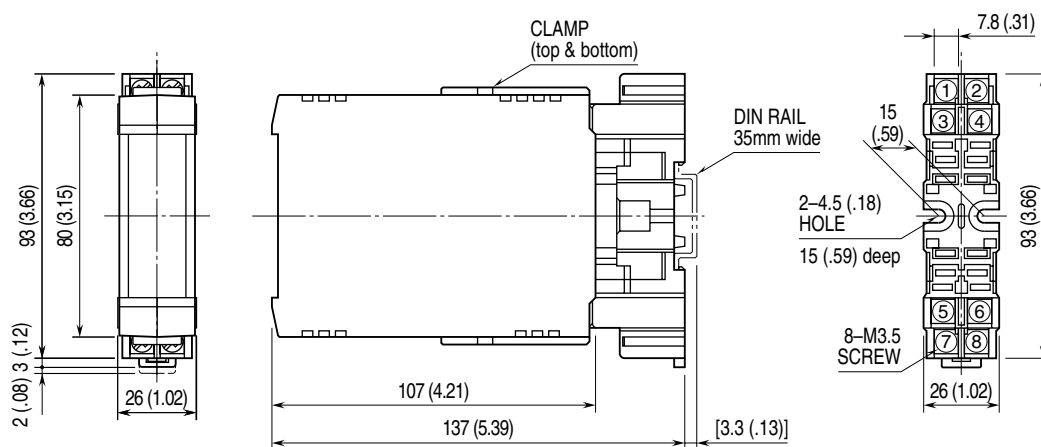

•When mounting, no extra space is needed between units.

CONNECTION DIAGRAM

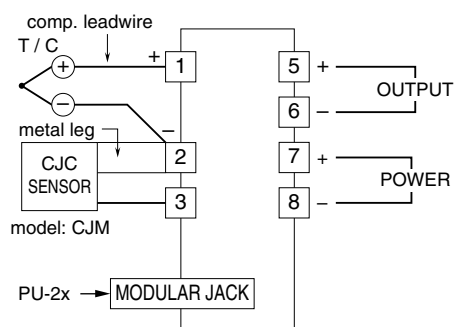

TERMINAL ASSIGNMENTS unit: mm (inch)

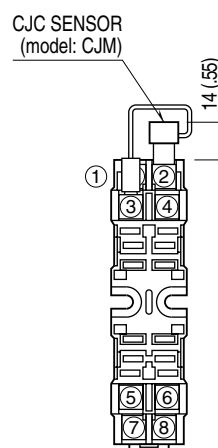

WIRING INSTRUCTIONS

■ SCREW TERMINAL

Torque: 0.8 N·m

CHECKING

- 1) Terminal wiring: Check that all cables are correctly connected according to the connection diagram.
- 2) Power input voltage: Check voltage across the terminal 7 – 8 with a multimeter.
- 3) Input: Check that the input voltage is within 0 – 100% of full-scale.

If the thermocouple or its extension wires are broken, the output goes over 100% (below 0% with downscale) due to burnout function. Check leadwires in such a case.

- 4) Output: Check that the load resistance meets the described specifications.

ADJUSTMENT PROCEDURE

This unit is calibrated at the factory to meet the ordered specifications, therefore you usually do not need any calibration, unless you need to match the signal to a receiving instrument or conduct regular calibration.

Zero and span are adjusted with using the Programming Unit (model: PU-2x).

Refer to the Operation Manual for Model PU-2x for explanations how to use the programmer.

■ WARNING ON USE OF THE PROGRAMMING UNIT

- Be sure to disconnect the Programming Unit before you turn on/off power supply to the unit.
- The output signal is held when the Programming Unit is connected. You need to disconnect when confirming current output values.

■ HOW TO CALIBRATE THE OUTPUT SIGNAL

Use a signal source and measuring instruments of sufficient accuracy level. Turn the power supply on and warm up for more than 10 minutes.

• Fine Output Calibration Using the Programming Unit (ITEM 19, 20)

ITEM 19 is for Zero, and ITEM 20 is for Span.

- 1) Turn the unit into Program mode (ITEM 01).
- 2) Apply simulated 0% input. Increase/decrease values (default: 0%) at ITEM 19 until the output signal is calibrated to actual 0%.
- 3) Apply simulated 100% input. Increase/decrease value (default: 100%) at ITEM 20 until the output signal is calibrated to actual 100%.
- 4) Apply simulated 0% input again and check 0% output.
- 5) When 0% value is changed, repeat the above procedure 2) – 4).

The 0% value may be shifted when the output span is greater than the input span (gain > 1).

PROGRAMMABLE ITEMS

The following items can be monitored and programmed. For detailed explanations, please refer to the Operation Manual for Model PU-2x (EM-9255), Section A.

[GROUP 01]

ITEM	MDFY.	DATA INPUT	DISPLAY	CONTENTS
01	S			MAINTENANCE SWITCH (lock command)
		0	MTSW: MON.MODE	MONITOR mode: data monitoring only
		1	MTSW: PRG.MODE	PROGRAM mode: "P" marked data modifiable
02	P	Alphabets & No.	TG: XXXXXXXXXXXX	Tag name entry (10 characters max.)
03	P	Number (%)	OUTPER XXX.XX	Output status monitor (%) & simulation output
04	D	No input	OUTTMP XXXX.XX	Output temperature monitor *1
05	D	No input	INPPER XXX.XX	Input status monitor (%)
06	D	No input	INPVAL XXXXXX	Input status monitor in mV
07	D	No input	CJMTMP XXX.XX	Cold junction compensation temperature (°C)
10	P			TYPE OF THERMOCOUPLE
		1	Tc-1: (PR)	(PR)
		2	Tc-2: K (CA)	K (CA)
		3	Tc-3: E (CRC)	E (CRC)
		4	Tc-4: J (IC)	J (IC)
		5	Tc-5: T (CC)	T (CC)
		6	Tc-6: B (RH)	B (RH)
		7	Tc-7: R	R
		8	Tc-8: S	S
		9	Tc-9: WRe 5-26	WRe 5-26
0	Tc-0: N	N		
14	P	Actual value	SCLLOW XXXXXX	Input range scaling 0% value
15	P	Actual value	SCLHIG XXXXXX	Input range scaling 100% value
				Use the same temp. unit as selected in ITEM 21.
19	P	Percentage	FINZER	Fine zero adjustment Initial status shows actual bias (%). When data is entered, output (%) is shown.
20	P	Percentage	FINSPN	Fine span adjustment Initial status shows actual gain (%). When data is entered, output (%) is shown.
21	P			TEMPERATURE SCALE
		0	TMPSCCL: [°C]	Program ITEM 21 first before ITEM 14/15 when °F or K calibration is needed. This procedure is necessary whenever thermocouple type is changed.
		1	TMPSCCL: [°F]	
2	TMPSCCL: [K]			

Modification Code

D: No modification (writing) possible. Used only for monitoring (reading).

S: Modifiable at any time.

P: Modifiable only when the MAINTENANCE SWITCH is in the "PRG" mode.

*1. Temperature is indicated in the unit selected in ITEM 21.

MAINTENANCE

Regular calibration procedure is explained below:

■ CALIBRATION

Warm up the unit for at least 10 minutes. Apply 0%, 25%, 50%, 75% and 100% input signal. Check that the output signal for the respective input signal remains within accuracy described in the data sheet. When the output is out of tolerance, recalibrate the unit according to the "ADJUSTMENT PROCEDURE" explained earlier.

LIGHTNING SURGE PROTECTION

We offer a series of lightning surge protector for protection against induced lightning surges. Please contact us to choose appropriate models.