

**ETHERNET/RS-485 ADAPTOR**  
(Modbus use)MODEL **GR8-EM****BEFORE USE ....**

Thank you for choosing M-System. Before use, please check contents of the package you received as outlined below.

If you have any problems or questions with the product, please contact M-System's Sales Office or representatives.

**■ PACKAGE INCLUDES:**

Ethernet/RS-485 adaptor.....(1)

**■ MODEL NO.**

Confirm Model No. marking on the product to be exactly what you ordered.

**■ INSTRUCTION MANUAL**

This manual describes necessary points of caution when you use this product, including installation, connection and basic maintenance procedures.

**POINTS OF CAUTION****■ CONFORMITY WITH EU DIRECTIVES**

- The equipment must be mounted inside a panel.
- The actual installation environments such as panel configurations, connected devices, connected wires, may affect the protection level of this unit when it is integrated in a panel system. The user may have to review the CE requirements in regard to the whole system and employ additional protective measures to ensure the CE conformity.

**■ POWER INPUT RATING & OPERATIONAL RANGE**

- Locate the power input rating marked on the product and confirm its operational range as indicated below:  
24V DC rating: 24V  $\pm$ 10%,  $\leq$  1.5W

**■ GENERAL PRECAUTIONS**

- Before you remove the unit or mount it, turn off the power supply for safety.

**■ ENVIRONMENT**

- Indoor use.
- When heavy dust or metal particles are present in the air, install the unit inside proper housing with sufficient ventilation.
- Do not install the unit where it is subjected to continuous vibration. Do not subject the unit to physical impact.
- Environmental temperature must be within -10 to +55°C (14 to 131°F) with relative humidity within 10 to 90% RH in order to ensure adequate life span and operation.

**■ WIRING**

- Do not install cables close to noise sources (relay drive cable, high frequency line, etc.).
- Do not bind these cables together with those in which noises are present. Do not install them in the same duct.

**■ AND ....**

- The unit is designed to function as soon as power is supplied, however, a warm up for 10 minutes is required for satisfying complete performance described in the data sheet.

## COMPONENT IDENTIFICATION

### ■ FRONT VIEW

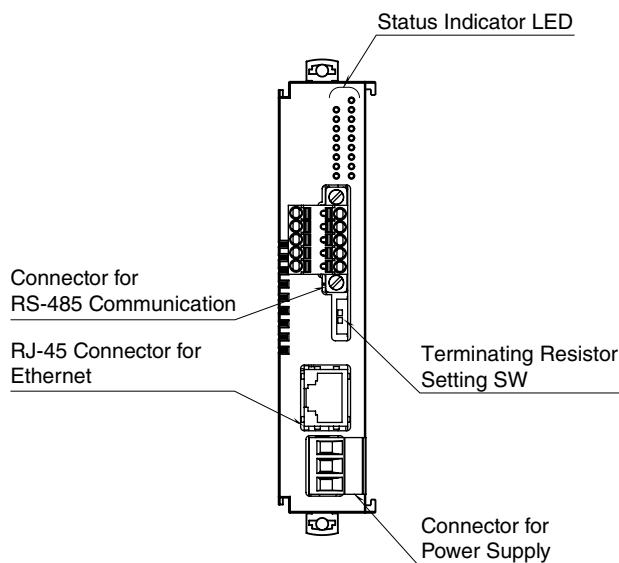

### ■ RIGHT SIDE VIEW

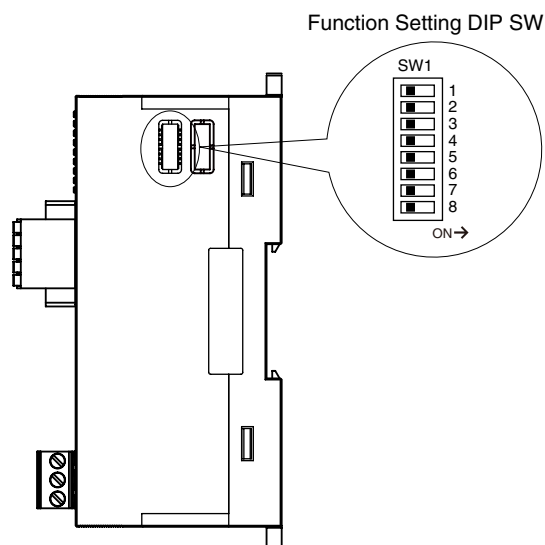

### ■ STATUS INDICATOR LED

ID	Color	Light	Module Status
RUN	Green	Blinking (1-sec cycle)	Normal mode
		Blinking in low speed (2-sec cycle)	Maintenance mode (with SW1-2 ON)
		Blinking in high speed (0.4-sec cycle)	Error (device error when the unit wouldn't recover even after power reactivation)
		OFF	Power is off or device error
ERR	Red	ON	Data error from RS-485 device
RD	Green	ON	Receiving data from the paired RS-485 station
SD	Green	ON	Sending data to the paired RS-485 station
LINK	Green	ON	Being linked with 10BASE or 100BASE
		Blinking	Sending/receiving data
		OFF	No link detected
LK100	Green	ON	Being linked with 100BASE
		OFF	Being linked with 10BASE or Not linked

### ■ DIP SW SETTING

(\*) Factory default setting

#### • IP Address

SW1-1	Mode	Function
OFF (*)	Normal mode	Set with configurator
ON	Factory default mode	When starting up with the SW ON, the unit temporarily operates by the factory default settings of network configuration, user ID and password. The stored settings, however, are maintained and the unit returns to the original settings upon restarting at normal mode. When network settings are changed during factory default mode, the changed settings are stored.

#### • Maintenance mode

SW1-2	Mode	Function
OFF (*)	Normal mode	Normal operation
ON	Maintenance mode	Stop output (Modbus function 05, 06, 15, 16 are disabled)

Note: Be sure to set unused SW1-3 through 1-8 to OFF.

### ■ TERMINATING RESISTOR SETTING SW

#### • Terminating resistor

TERM	INCORPORATED TERMINATING RESISTOR
OFF	Disabled
ON (*)	Enabled

### ■ RS-485 CONNECTOR TERMINAL ASSIGNMENT

Unit side connector: MC1,5/5-GF-3,5  
(Phoenix Contact)

Cable side connector: TFMC1,5/5-STF-3,5  
(Phoenix Contact)

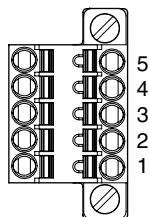

No.	ID	FUNCTION
5	FE	FE
4	SH	SHIELD
3	DG	DG
2	DB	DB
1	DA	DA

### ■ POWER SUPPLY TERMINAL ASSIGNMENT

Unit side connector: MSTB2,5/3-G  
(Phoenix Contact)

Cable side connector: MSTB2,5/3-ST  
(Phoenix Contact)

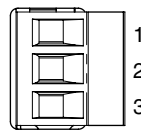

No.	ID	FUNCTION
1	(+)	Power supply 24V (+)
2	(-)	Power supply 24V (-)
3	FE1	Power supply earth

## WIRING INSTRUCTIONS

### ■ EURO TYPE CONNECTOR TERMINAL (POWER SUPPLY)

Applicable connector: MSTB2,5/3-ST (Phoenix Contact)  
attached to the product

Applicable wire size: 0.2 – 2.5 mm<sup>2</sup>

Stripped length: 7 mm

Recommended pin terminals :

AI0,25-6BU 0.25 mm<sup>2</sup> (Phoenix Contact)

AI0,34-6TQ 0.34 mm<sup>2</sup> (Phoenix Contact)

AI0,5-6WH 0.5 mm<sup>2</sup> (Phoenix Contact)

AI0,75-6GY 0.75 mm<sup>2</sup> (Phoenix Contact)

AI1-6RD 1.0 mm<sup>2</sup> (Phoenix Contact)

AI1,5-6BK 1.5 mm<sup>2</sup> (Phoenix Contact)

AI2,5-6BU 2.5 mm<sup>2</sup> (Phoenix Contact)

### ■ TENSION CLAMP TERMINAL BLOCK (RS-485)

Applicable connector: TFMC1,5/5-STF-3,5 (Phoenix Contact)  
attached to the product

Applicable wire size: 0.2 – 1.5 mm<sup>2</sup>

Stripped length: 10 mm

Recommended pin terminals:

AI0,25-10YE 0.25 mm<sup>2</sup> (Phoenix Contact)

AI0,34-10TQ 0.34 mm<sup>2</sup> (Phoenix Contact)

AI0,5-10WH 0.5 mm<sup>2</sup> (Phoenix Contact)

AI0,75-10GY 0.75 mm<sup>2</sup> (Phoenix Contact)

## INSTALLATION

### ■ COUPLED WITH DL8

The unit coupled with DL8 is used by connecting to DL8 and R8 series I/O modules. First, mount all the DL8 and I/O modules with the power OFF. Connect the unit in the same manner to DL8 and I/O modules. Attach the protective cover of DL8 to GR8-EM.

Note: Make sure to install the unit at the end of all the other modules. With the unit installed between DL8 and I/O modules, I/O modules after the unit can not perform internal communication or the power can not be supplied to these I/O modules.

Confirm that the locking clamps of the unit are set. Insert the unit straight in perpendicularly to the rail such that the grooves of the unit and the module on the immediate left engage each other. (A & B in the below figure)

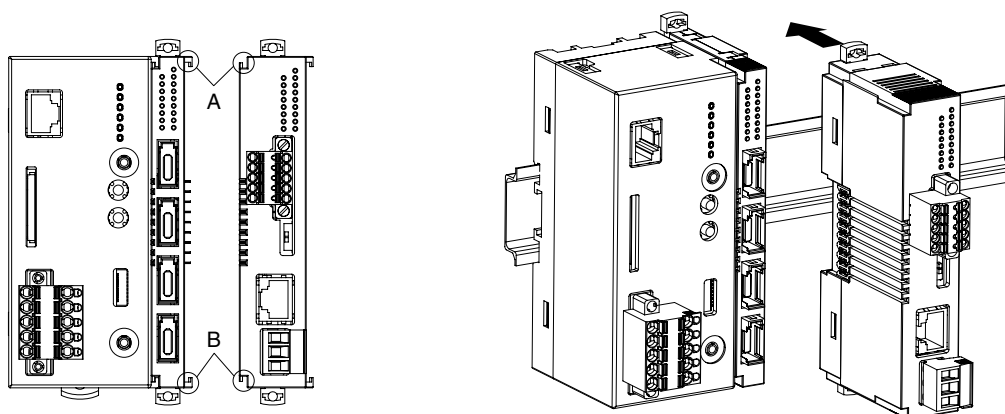

### • HOW TO ATTACH PROTECTIVE COVER

Align the hooks on the cover with the grooves of the unit and slide the cover straight until the hooks are latched.

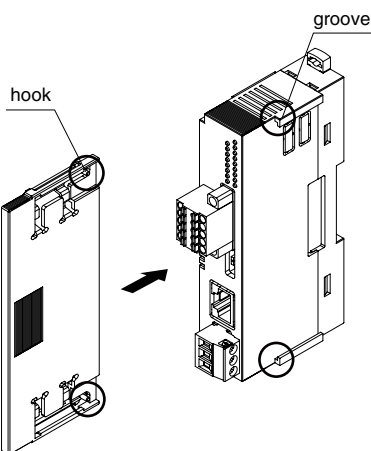

When removing the cover by DIP SW setting, pull it out while squeezing the hooks inward.

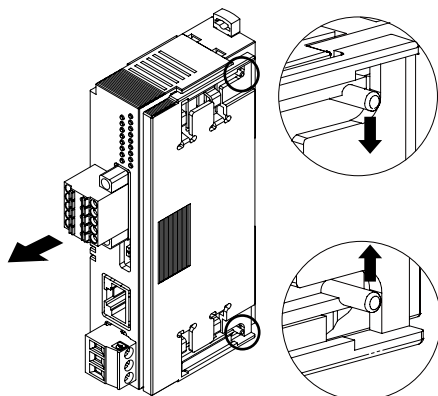

**■ SINGLE USE****• HOW TO INSTALL**

- A) Hang the upper hook at the rear side of unit on the DIN rail. Push in the lower in keeping pressing the unit to the DIN rail.
- B) To remove the unit, push down the DIN rail adaptor using a minus screwdriver. Pull out the lower part of the unit. Remove the upper part from the DIN rail.

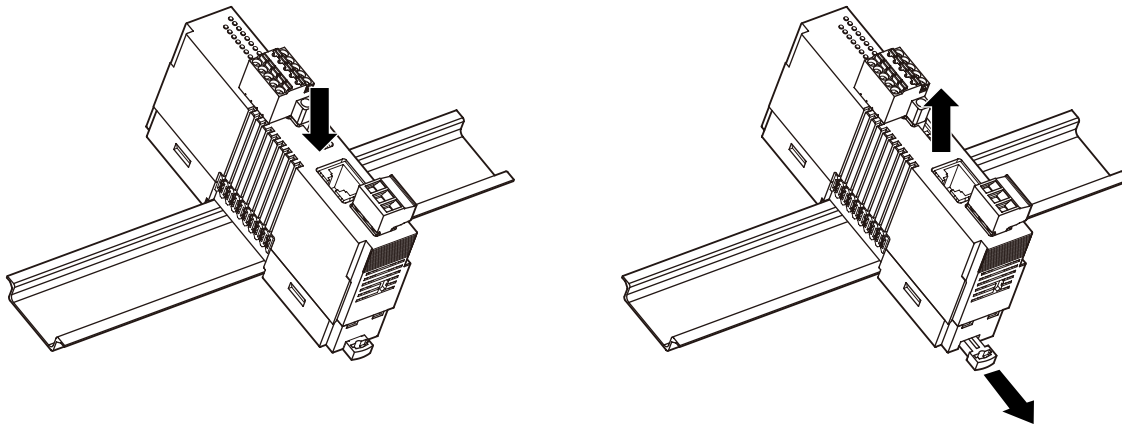

Note: When the unit is mounted on a DIN rail attached on the wall surface in vertical direction, use of an attachment plate to prevent the module from sliding down is recommended.

## TERMINAL CONNECTION

Connect the unit as in the diagram below.

### EXTERNAL DIMENSIONS unit: mm (inch)

#### • COUPLED WITH DL8

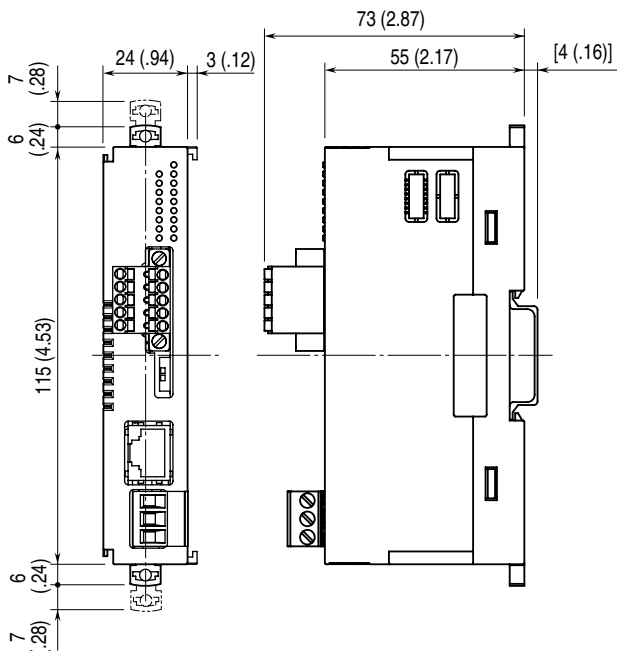

#### • SINGLE USE

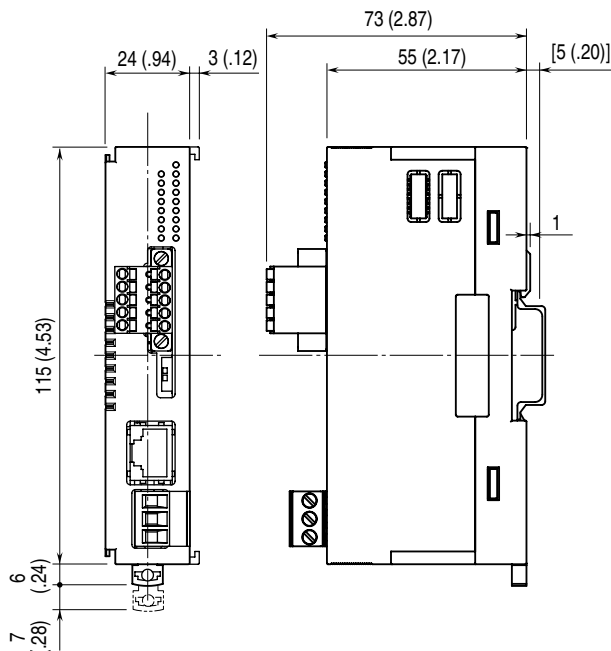

### CONNECTION DIAGRAM

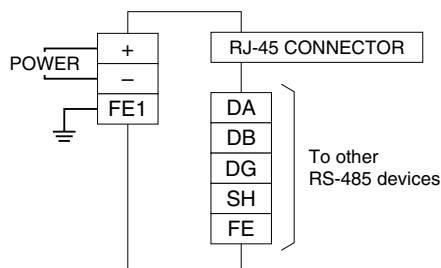

## MODBUS WIRING CONNECTION

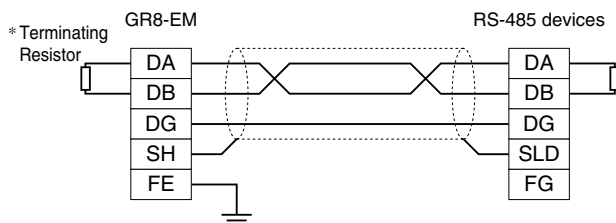

\* Turn the terminating resistor SW "ON" to use the incorporated terminating resistor.

## COMMUNICATION

### ■ Ethernet, Modbus / TCP

- Standard: IEEE 802.3u
- Protocol: TCP/IP (compatible to Modbus/TCP Standard by Schneider Automation)
- Transmission speed: 10 / 100M bps (Auto Negotiation)
- Transmission media: 10BASE-T (STP cable; Category 5)
- 100BASE-TX (STP cable; Category 5e)
- Maximum segment length: 100 meters
- Number of connections: 8
- Configuration: Via a web browser software
  - IP address: 192.168.0.1 (Factory default setting)
  - Port No.: 502 (Factory default setting)
  - Subnet mask
  - Default gateway
  - User name, password
  - Modbus exception response
  - Connection time out: 1 min. (\*) to 60 min.\*1

\*1. Connection is severed automatically when no query is sent from the host for a certain time.

### ■ RS-485, Modbus / RTU

- Protocol: Modbus RTU
- Configuration: Bus type multi-drop
- Standard: Conforms to TIA/EIA-485-A
- Communication: Half-duplex, asynchronous, no procedure
- Transmission distance: 500 meters max.
- Transmission media: Shielded twisted-pair cable (CPEV-S 0.9 dia.)
- Terminating resistor: Built-in 110 Ω (DIP Switch, default: enabled)
- Configuration: Via a web browser software
- Baud rate: 2.4, 4.8, 9.6, 19.2 (\*), 38.4, 57.6, 115.2 kbps
  - Stop bit: 1 (\*), 2
  - Parity: None, Even, Odd (\*)
  - Read timeout: 1000 msec. (\*), 10 – 10 000 msec.
  - Write timeout: 1000 msec. (\*), 10 – 10 000 msec.
  - Cache function: Enabled (\*), disabled
  - Inter-frame interval: 10 msec. (\*), 0 – 500 msec.

(\*) Factory default setting

### ■ SUPPORTED Modbus COMMANDS

Read Coil Status (01)  
 Read Input Status (02)  
 Read Holding Registers (03)  
 Read Input Registers (04)  
 Force Single Coils (05)  
 Preset Single Registers (06)  
 Diagnostics (08)  
 Fetch Comm. Event Counter (11)  
 Fetch Comm. Event Log (12)  
 Force Multiple Coils (15)  
 Preset Multiple Registers (16)  
 Report Slave ID (17)

## ■ CACHE FUNCTION

### • General

The GR8-EM regularly communicates with the client (RS-485) I/O modules regardless of the presence or absence of requests from the host (Ethernet) and stores data in its Cache area. Whenever a query is received from the host, the GR8-EM sends data stored in the Cache without loss of time to scan the client each time.

### • When many devices are connected to RS-485

When devices connected to RS-485 and requests of query increase in number, update cycle for data stored in a cache becomes slow and data become delayed data against actual data. If this delay causes problem, disable the cache.

### • Modbus commands supported for Cache function

Read Coil Status (01)  
 Read Input Status (02)  
 Read Holding Registers (03)  
 Read Input Registers (04)

### • Number of Cache

Up to 100 Cache areas (100 queries of the commands supported for Cache) are usable.

Each Cache is managed with Slave address, Function code, Begin address and Number of register.

One Cache area is shared by identical queries. If one or more of the above differs, another Cache area is assigned.

When the number of Cache areas reaches 100, following queries will be handled as normal queries without Cache function.

Note: If no query is sent from the host for 10 seconds, the Cache is disabled.

If data received from the client result in three consecutive errors, or there is no communication between the client for 10 sec., the Cache is disabled.

### • Modbus/TCP & Modbus RTU

Query and Response message formats are different between Modbus/TCP (Ethernet) and Modbus RTU (RS-485). For detailed explanations, please refer to Modbus Protocol Reference Guide (EM-5650).

For example, when a query is sent to read data addresses 30017 to 30018 at the slave address 1 and '12345678' is stored at these addresses: (hexadecimal)

#### QUERY

Modbus/TCP	00	01	00	00	00	06	01	04	00	10	00	02
	(1)	(2)	(3)	(4)	(5)	(6)						
Modbus RTU				01	04	00	10	00	02	70	0E	
				(4)	(5)	(6)	(7)					

#### RESPONSE

Modbus/TCP	00	01	00	00	00	07	01	04	04	12	34	56	78
	(1)	(2)	(3)	(4)	(5)	(6)							
Modbus RTU				01	04	04	12	34	56	78	80	B0	
				(4)	(5)	(6)	(7)						

(1) Transaction identifier (2 bytes): The value in the query is copied into the response.

(2) Protocol identifier (2 bytes): Fixed to zero (0).

(3) Length (2 bytes): Number of following bytes.

(4) Unit identifier (1 byte): Modbus RTU slave address.

(5) Function Code (1 byte)

(6) Data fields (variable length): Related to the Function Code.

(7) CRC check (2 bytes)

(4), (5) and (6) are common to both Modbus/TCP and Modbus RTU.

Modbus/TCP is preceded by six (6) bytes of data, while Modbus RTU is followed by a CRC.



## SYSTEM CONFIGURATION EXAMPLE

Devices other than the GR8-EM in below provided by the user.

### ■ COUPLED WITH DL8

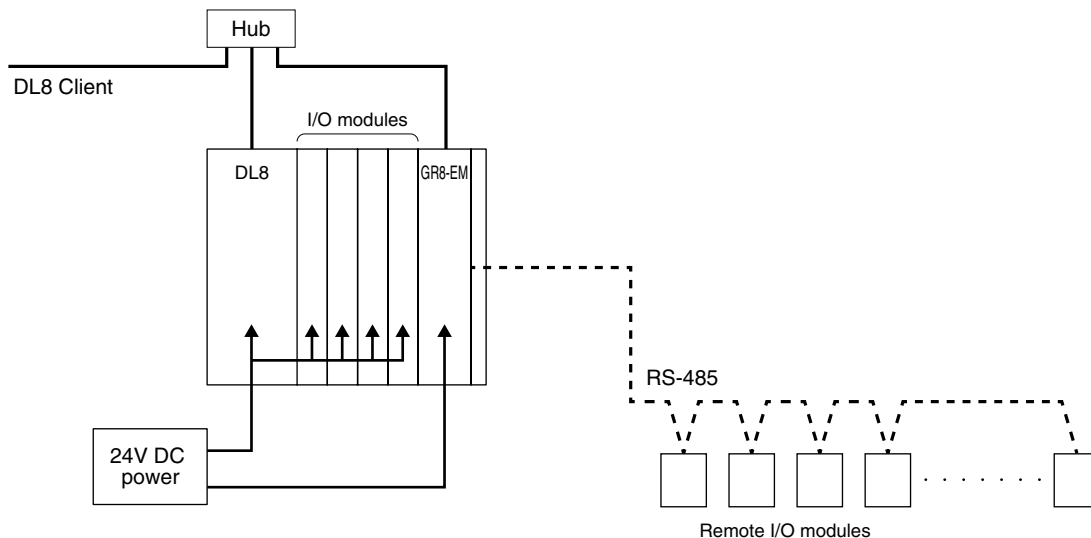

Note: It is not available to supply the power via DL8.  
Supply the power with the connector for power supply.

### ■ SINGLE USE

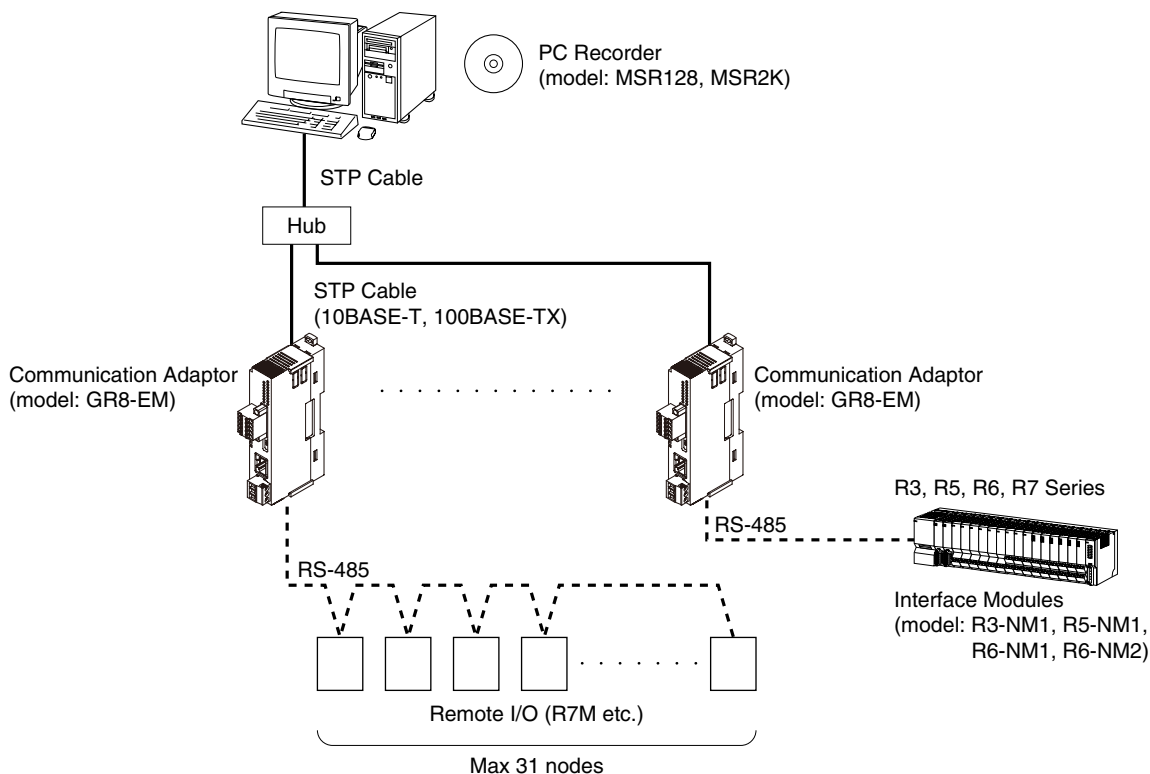

## STARTUP WITH DEFAULT SETTINGS

When starting up with DIP SW1-1 on the right side of the unit “ON”, the unit temporarily operates by the factory default settings of network configuration and user login password to setting menu as in the table below. (Factory default mode)

Use the factory default mode to confirm the settings when you forget IP address or login password. The original set values are displayed by opening the setting menu. The settings can be changed at the factory default mode as well.

Restart the unit with SW1-1 “OFF” to return to the normal mode.

ITEM	FACTORY DEFAULT SETTING
IP Address	192.168.0.1
Subnet Mask	255.255.255.0
Default Gateway	0.0.0.0
User Name	admin
Password	admin

## CONFIGURATION WITH WEB BROWSER

The GR8-EM is capable of Web server. A PC, tablet or smart phone can configure the GR8-EM via Ethernet.

Note: As the GR8-EM employs only Ethernet I/F, A PC, tablet or smart phone, which has only wireless LAN I/F, cannot be connected directly. Provide a wireless LAN access point etc. by users.

Though the web server is designed for applicable to many web browsers supporting HTML5, operation with all web browsers or environment cannot be guaranteed. Please notice that even with the web browsers checked operation by M-System, there are possibilities that display is corrupted or specific function does not work by configuration of the web browsers or installed security software.

### COMPATIBLE WEB BROWSERS CHECKED BY M-SYSTEM

DEVICES	WEB BROWSERS
PCs with Windows 7, Windows 8.1, Windows 10	Internet Explorer 11.0.47 Firefox 62.0.3 Chrome 69.0.3497.100 Edge 44.17763.1.0
iPhone or iPad with iOS 11.4.1	Safari 11.4.1
Tablet or smart phone with Android 8.0.0	Chrome 69.0.3497.100

### ■ CONFIGURATION

When IP address is factory default, 192.168.0.1, set the address for PCs 192.168.0.5 etc. which can communicate with 192.168.0.1, and connect the unit and the PC with Ethernet cable. After connection, specify and connect to <http://192.168.0.1/> with the web browser of the PC, tablet or smart phone.

The following initial screen is displayed on the web browser, after the unit is started up and the devices are connected via the web browser. The view of the web browser differs depending on your OS, web browser and its version. The views on this instruction manual are with Internet Explorer on Windows 8.1. The IP address is 192.168.0.1.

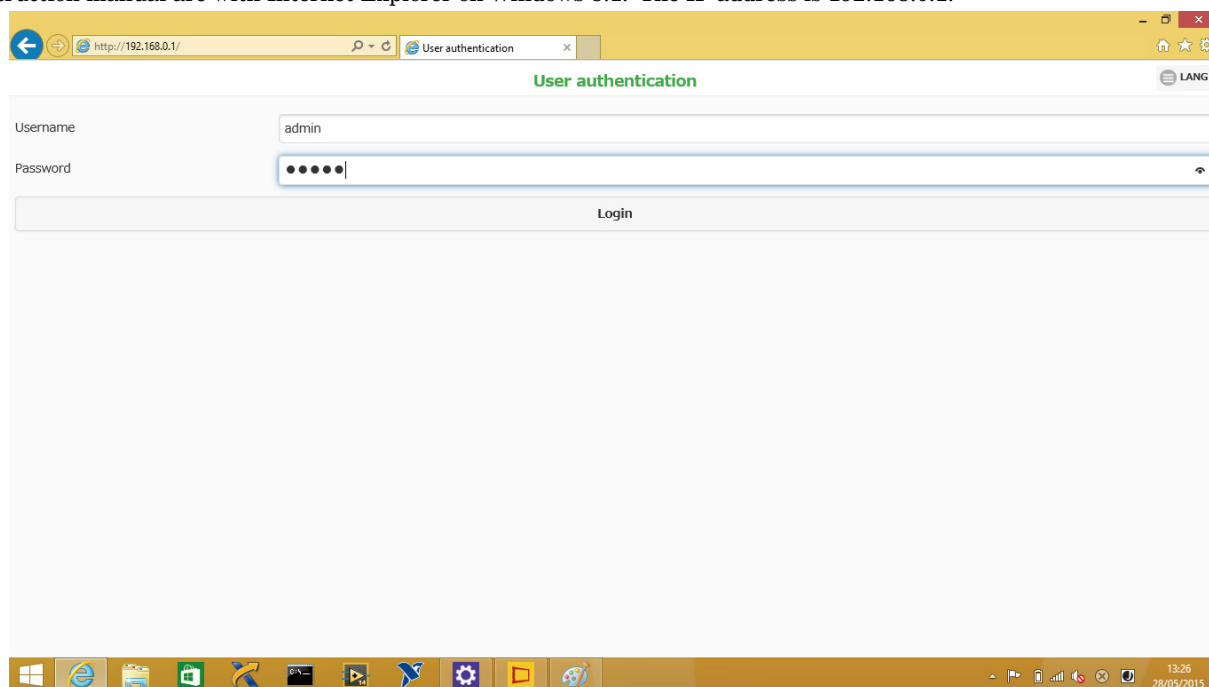

## ■ SETTING MENU

Enter user name and password on the “User authentication” of the initial view and login. The default user name and password is “admin” for both.

After login, the following Setting Menu is displayed. Choosing each menu enables to move on to each information or setting view.

Pressing “LANG” button enables to select the language between English and Japanese.

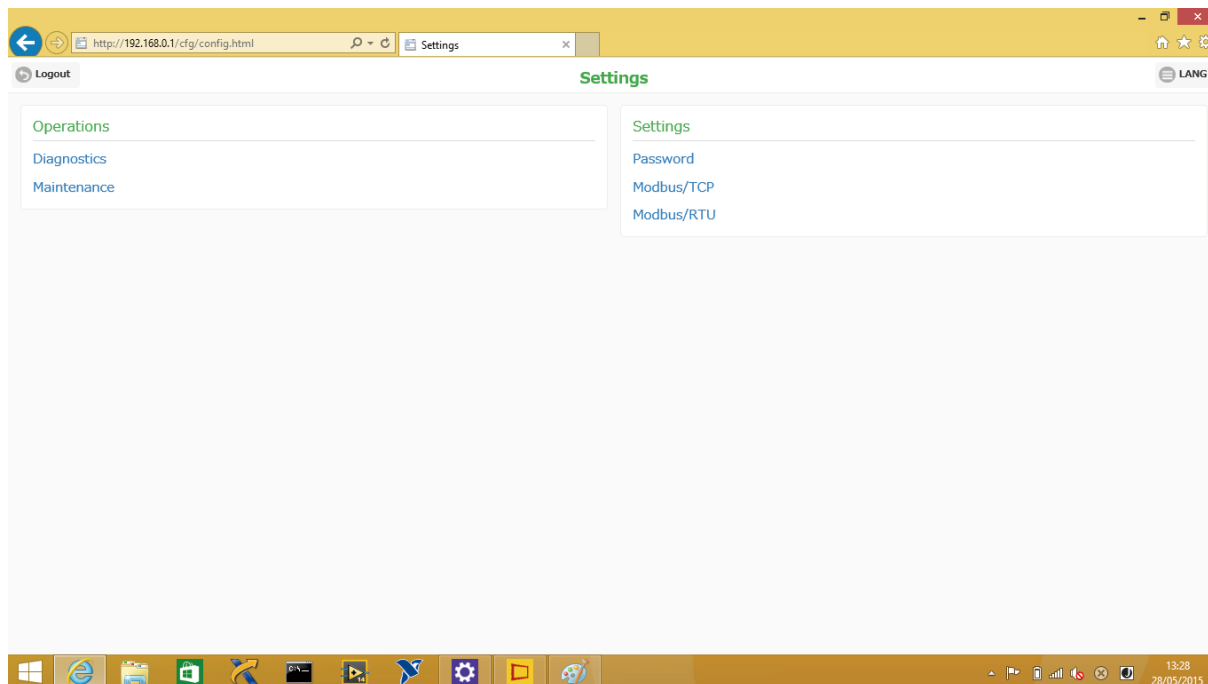

## ■ PASSWORD

Set the user name and password to be required for user authentication to connect the pages for various settings. After setting, clicking “Save” button on the upper right corner enables to save them in the unit. Clicking “Back” button enables to return previous view before saving.

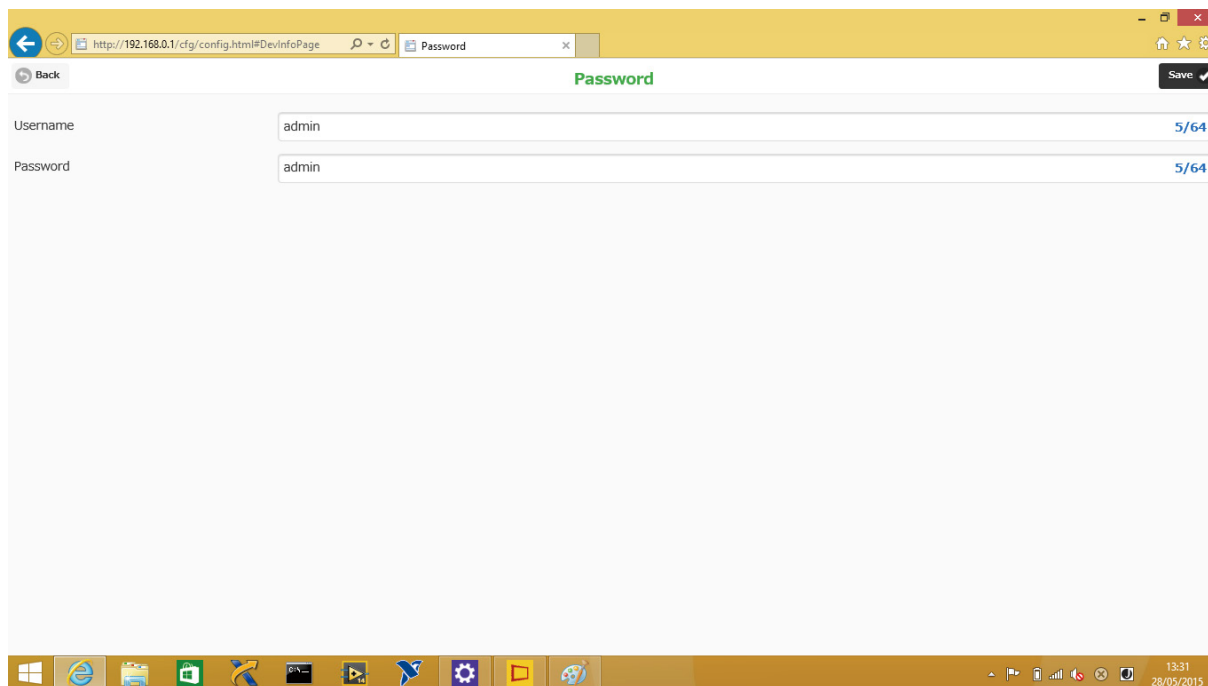

ITEM	DESCRIPTION
Username	Set the user name for login to setting menu. Max. 64 characters are available. *1
Password	Set the password for login to setting menu. Max. 64 characters are available. *1

\*1. ”, # and \ are excluded.

## MODBUS/TCP CONFIGURATION

Configure the items for Modbus/TCP. After setting, clicking “Save” button on the upper right corner enables to save them in the unit. Clicking “Back” button enables to return previous view before saving.

The screenshot shows a web browser window with the URL `http://192.168.0.1/cfg/config.html#TCPIPPage`. The page is titled "Modbus/TCP" and contains a configuration form with the following fields:

- IP address: 192.168.0.1
- Subnetmask: 255.255.255.0
- Default gateway: 0.0.0.0
- Port: 502
- Modbus exception response: Disable 06(BUSY),0B(ERROR)
- Connection timeout (min): 1

Buttons for "Back" and "Save" are visible at the top of the form.

ITEM	DESCRIPTION
IP address	Set the IP address for the unit. Range : 0.0.0.0 to 255.255.255.255
Subnetmask	Set the Subnet Mask for the unit. Range : 0.0.0.0 to 255.255.255.255
Default gateway	Set the router address connected to external network. 0.0.0.0 (not used) is available for local network, which does not communicate with external network. Range : 0.0.0.0 to 255.255.255.255
Port	Set the port number for Modbus/TCP. Range : 0 to 65535
Modbus exception response	Set if respond or not to exception code defined by Modbus. Choose among not return 06 (BUSY), 0B (ERROR) and return 06 (BUSY), 0B (ERROR).
Connection timeout : (min)	Set the time to cut off the connection when there are no transmission or receiving within certain time from connection established. Range : 1 to 60 minutes

## ■ MODBUS/RTU CONFIGURATION

Configure the items for Modbus/RTU. After setting, clicking “Save” button on the upper right corner enables to save them in the unit. Clicking “Back” button enables to return previous view before saving.

The screenshot shows a web browser window with the URL <http://192.168.0.1/cfg/config.html#ModbusPage>. The page is titled "Modbus/RTU" and has a "Save" button in the top right corner. The configuration items are as follows:

Item	Value
Transfer rate	38400 bps
Parity bit	Odd
Stop bit	1 bit
Read timeout (ms)	1000
Write timeout (ms)	1000
Cache function	Enable
Inter-frame interval (ms)	10

ITEM	DESCRIPTION
Transfer rate	Set the transfer rate. Choose among 2400, 4800, 9600, 19200, 38400, 57600 or 115200 bps.
Parity bit	Set the parity bit. Choose among None, Odd or Even.
Stop bit	Set the stop bit. Choose between 1 bit and 2 bits.
Read time out (ms)	Set the time out for read out function (msec.). Range : 10 to 10000 milli-seconds
Write time out (ms)	Set the time out for write in function (msec.). Range : 10 to 10000 milli-seconds
Cache function	Set the use of cache. Choose between Enable and Disable.
Inter-frame Interval (ms)	Set the delay time from when response receiving till when transmitting next transmit frame (msec.). Range : 0 to 500 milli-seconds

## ■ DIAGNOSTICS INFORMATION

Device information and statistics of Modbus/TCP and Modbus/RTU are displayed.

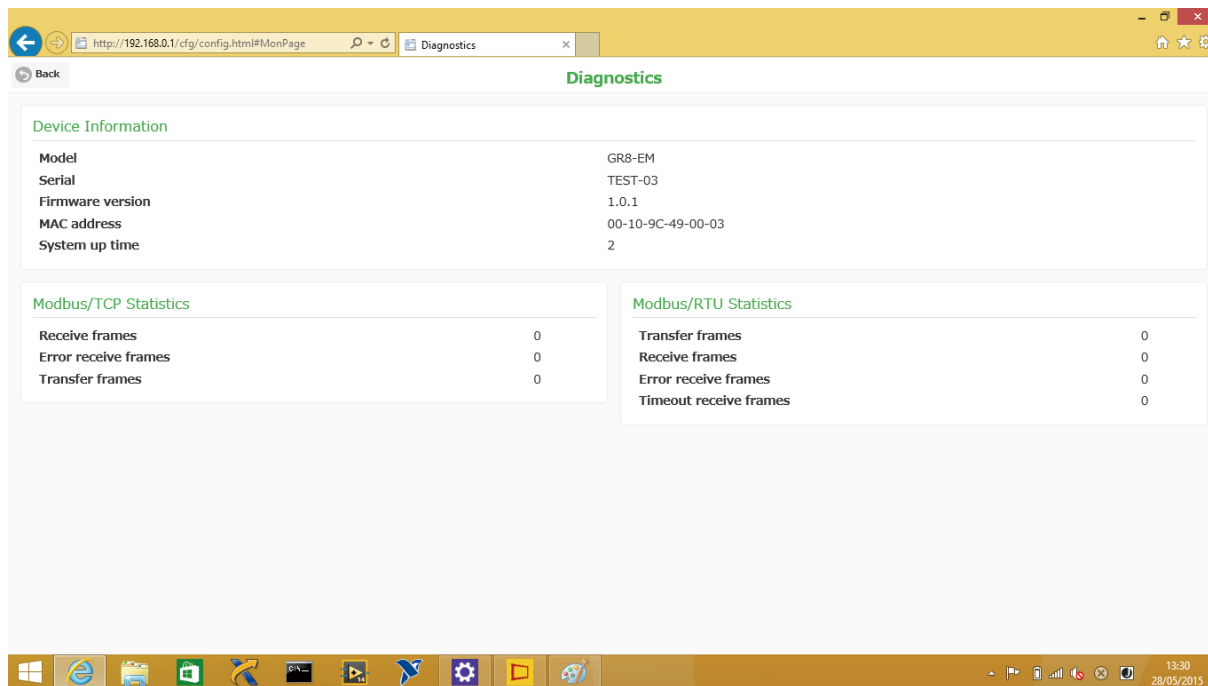

## ■ DEVICE INFORMATION

ITEM	DESCRIPTION
Model	Model of the unit
Serial	Serial number of the unit
Firmware version	Firmware version of the unit
MAC address	Ethernet MAC address of the unit
System up time	Operating time from power on

## ■ Modbus/TCP STATISTICS

ITEM	DESCRIPTION
Receive frames	Received request numbers of Modbus/TCP
Error receive frames	Numbers of error frame of received request
Transfer frames	Numbers of transmitting response of Modbus/TCP

## ■ Modbus/RTU STATISTICS

EVENT LOG	DESCRIPTION
Transfer frames	Modbus/RTU request transmitting numbers to device
Receive frames	Normal response receive numbers from device (Including the case Modbus response is error response)
Error receive frames	The numbers that response is error frame
Timeout receive frames	The numbers of time out that there are no response

## ■ MAINTENANCE

Performing maintenance of the unit.

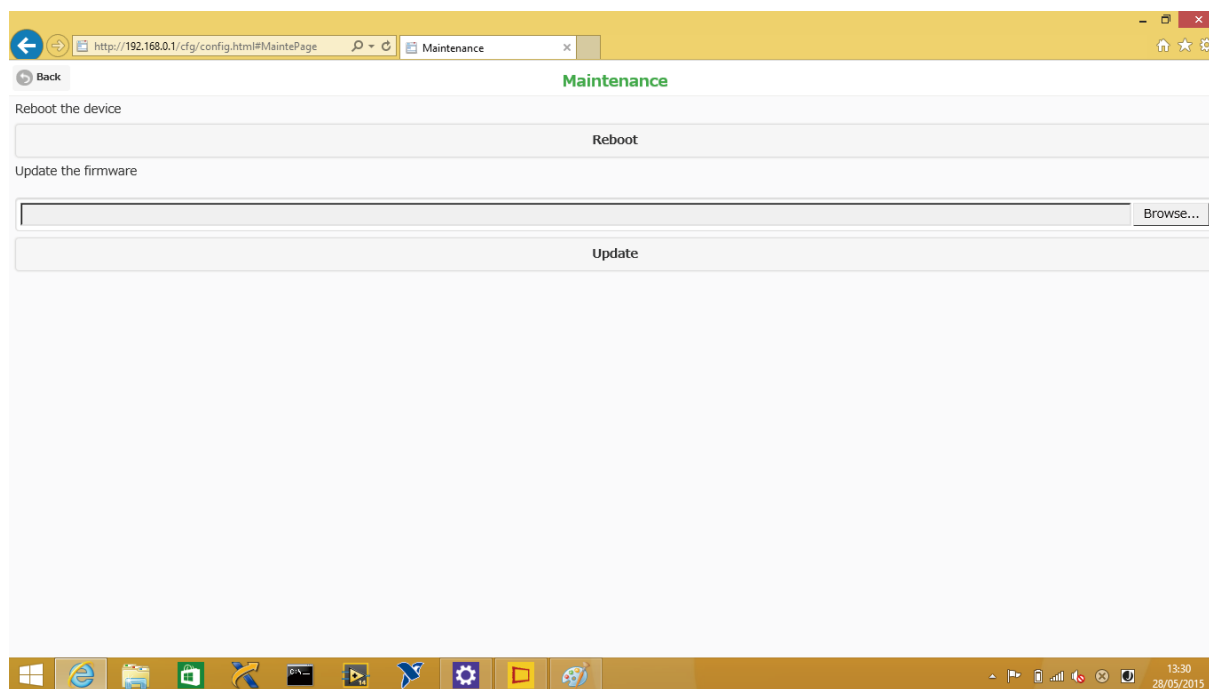

ITEM	DESCRIPTION
Reboot the device	Clicking “Reboot” enables to restart the unit
Update the firmware	Firmware update is available in order to add new functions and improve operations. Download the firmware from M-System web site. After browsing the file, clicking “Update” button enables to start the firmware update. Do not turn off the power while the firmware update is proceeding.