

BEFORE USE

Thank you for choosing us. Before use, please check contents of the package you received as outlined below.

If you have any problems or questions with the product, please contact our sales office or representatives.

■ PACKAGE INCLUDES:

Bargraph indicating alarm

(Body + scale plate + mounting bracket × 2pcs. + packing)...(1)

Engineering unit label sheet(1)

■ MODEL NO.

Confirm Model No. marking on the product to be exactly what you ordered.

■ INSTRUCTION MANUAL

This manual describes necessary points of caution when you use this product, including installation and connection.

POINTS OF CAUTION**■ POWER INPUT RATING & OPERATIONAL RANGE**

- Locate the power input rating marked on the product and confirm its operational range as indicated below:

100 – 240V AC rating: 85 – 264V, 47 – 66 Hz

approx. 5VA at 100V AC

approx. 6.5VA at 200V AC

approx. 7.5VA at 264V AC

24V DC rating: 24V ±10%, approx. 3W

■ GENERAL PRECAUTIONS

- Before you remove or mount the device, turn off the power supply and input signal for safety.
- Be sure to put the terminal cover on while the power is supplied.

■ ENVIRONMENT

- Indoor use.
- When heavy dust or metal particles are present in the air, install the device inside proper housing with sufficient ventilation.
- Do not install the device where it is subjected to continuous vibration. Do not subject the device to physical impact.
- Environmental temperature must be within -5 to 55°C (23 to 131°F) with relative humidity within 10 to 90% RH in order to ensure adequate life span and operation.
- Be sure that the ventilation slits are not covered with cables, etc.

■ WIRING

- Make sure for safety that only qualified personnel perform the wiring.
- Do not install cables close to noise sources (relay drive cable, high frequency line, etc.).
- Do not bind these cables together with those in which noises are present. Do not install them in the same duct.

■ AND

- The device is designed to function as soon as power is supplied, however, a warm up for 10 minutes is required for satisfying complete performance described in the data sheet.

INSTALLATION

■ PANEL CUTOUT unit: mm [inch]

• Single Mount Base

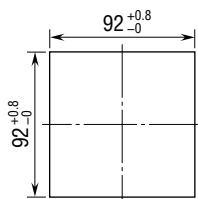

• Multi Mount Base

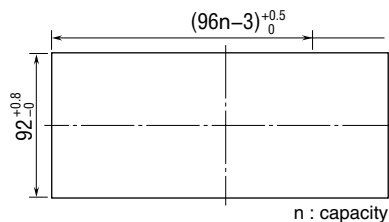

Panel thickness: 0.5 – 10 [.02 to .39]

■ CAUTION

- Install the device to vertical panel so that its function buttons are at the bottom side. Installing by other direction will cause degradation of life span or performance due to rise of the internal temperature.
- Ensure that there is sufficient space for ventilation inside a panel. Do not install above the devices that generate high heat such as heaters, transformers or resistors. Observe at the minimum of 55 mm (2.2") in vertical direction, minimum of 30 mm (1.2") in horizontal direction for maintenance purpose.

■ HOW TO MOUNT THE DEVICE ON A PANEL

- 1) Remove the mounting brackets.
- 2) Remove the terminal cover and insert it into the panel cutout prior to insertion of the device.
- 3) Insert the device into the panel cutout. The watertight packing must be in place.
- 4) Hang the hooks of the mounting brackets at the square holes on the upper and bottom side of the device. Tighten screws of the brackets until the device is fixed to the panel.

(torque 0.5 N·m)

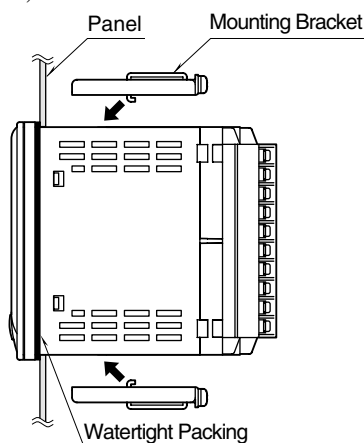

■ HOW TO REMOVE THE TERMINAL COVER

Insert the minus tip of a screwdriver into each hole at the four corners of the cover and pull it to the direction as indicated below to separate the terminal cover.

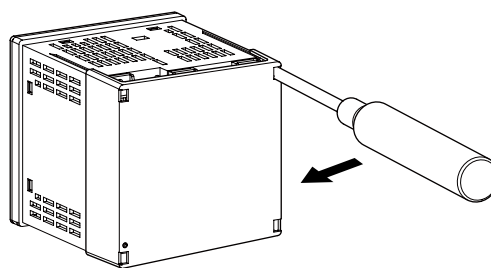

■ HOW TO REMOVE THE TERMINAL BLOCK

- The terminal block is separable in two pieces. Loosen two screws on top and bottom of the terminal block to separate.
- Be sure to turn off the power supply, input/output signal and communication signal before separating the terminal block.
- Each terminal block has ID keys so that it can be inserted to applicable terminal socket only.

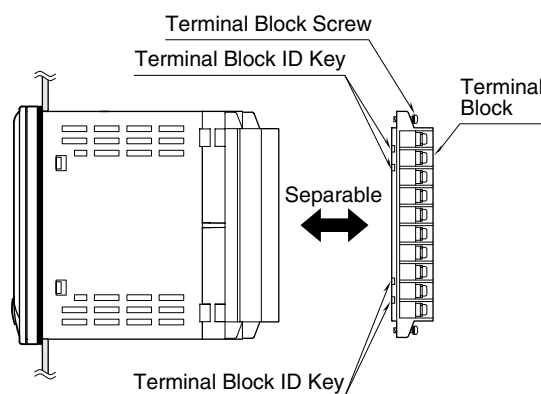

TERMINAL CONNECTIONS

Connect the device as in the diagram below or refer to the connection diagram on the terminal cover.

EXTERNAL DIMENSIONS unit: mm [inch]

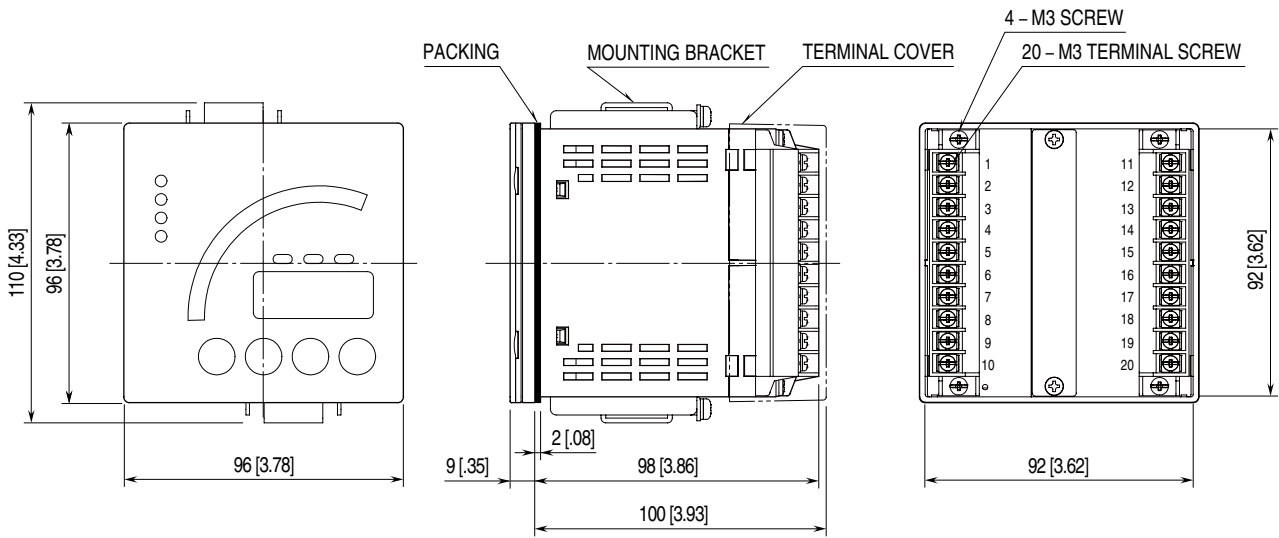

CONNECTION DIAGRAM

49AV3-0

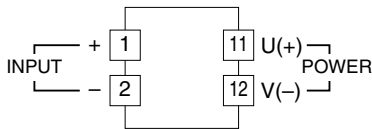

Relay Protection AC Powered

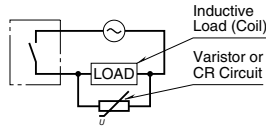

DC Powered

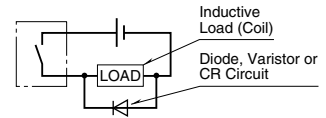

49AV3-2

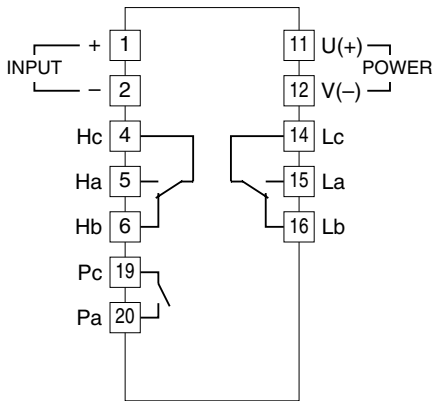

49AV3-4

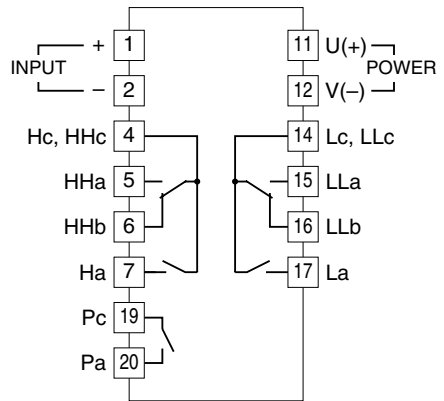

FRONT PANEL CONFIGURATION

FRONT VIEW

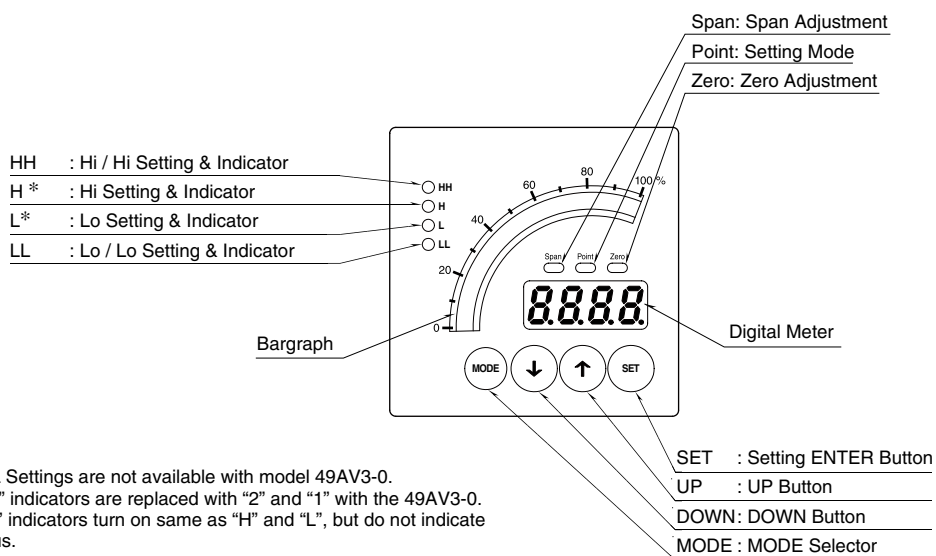

Note 1: HH, H, L, LL Settings are not available with model 49AV3-0.
 * "H" and "L" indicators are replaced with "2" and "1" with the 49AV3-0.
 "2" and "1" indicators turn on same as "H" and "L", but do not indicate relay status.

Note 2: HH, LL Settings are not available with model 49AV3-2.

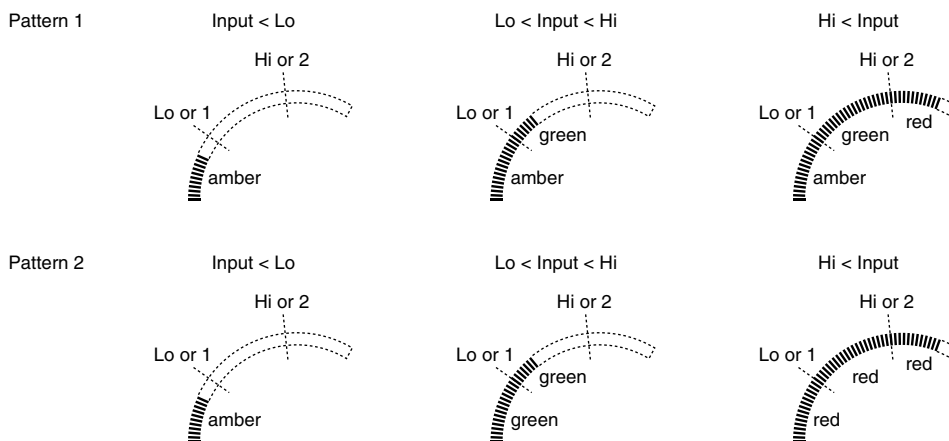

SETTING PROCEDURE

■ GENERAL SETTING FLOWCHART

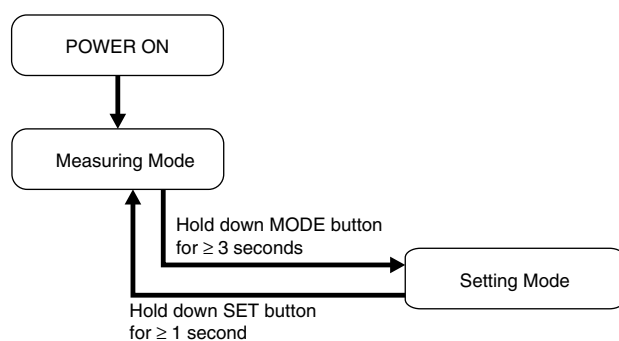

■ OPERATIONS IN SETTING MODES

• Display

The digital meter shows the current settings while the panel meter is in the setting mode.

• Shifting through setting parameters

In any setting mode, pressing DOWN button shifts one parameter to the next. Pressing UP button shifts one to the previous.

• Changing parameters

- 1) Press MODE button while the one of the setting parameter is displayed to display the current value of the setting parameter.
- 2) The value can be changed by pressing UP button or DOWN button while the current value is displayed.
- 3) After completing the settings, press MODE button to determine the value and the setting parameters are displayed.
- 4) In the setting mode, if operation is not performed for longer than one minute during changing the setting, the setting is discarded and the display switches to the parameter name.
Other than during changing the setting, the display switches to the measuring mode.

• Turning off displays

Pressing DOWN button for longer than 2 seconds in the measuring mode turns the bargraph off.

Pressing UP button for longer than 2 seconds turns the digital meter off.

In order to turn these displays on, proceed the same operation, or turn power supply off and on.

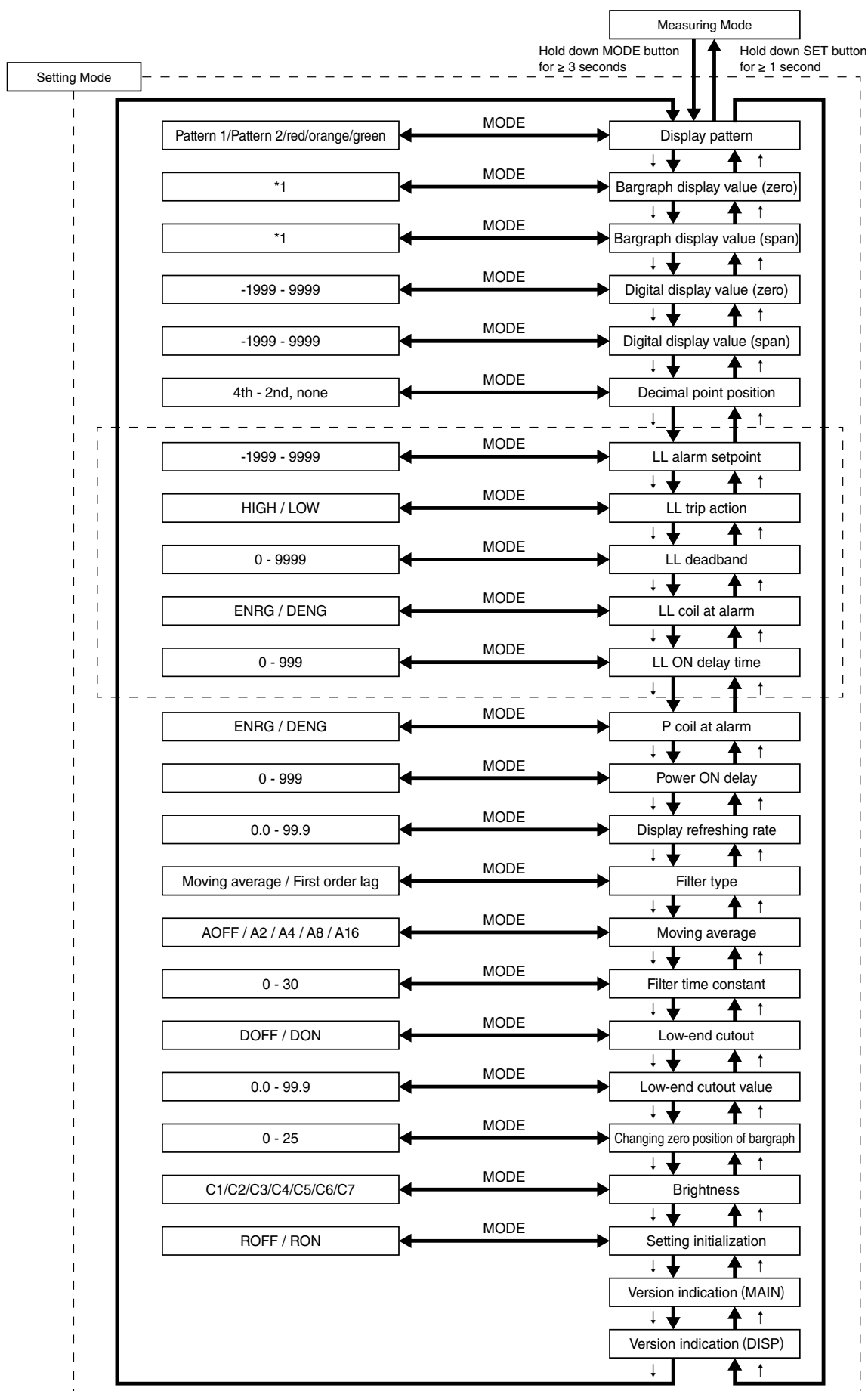

*1. For details, refer to the parameter list.

Note: LL alarm setpoint, LL trip action, LL deadband, LL coil at alarm, and LL ON delay time are the same setting parameter as L, H and HH.

• PARAMETER LIST

PARAMETER	PARAMETER NAME	SETTING RANGE	DEFAULT VALUE
Display pattern	<i>dPPt</i>	<i>PRt 1/PRt 2/ rEd/OnG/ On</i>	<i>PRt 1</i>
Bargraph display value (zero)	<i>b Zr</i>	-	-
Bargraph display value (span)	<i>b SP</i>	-	-
Digital display value (zero)	<i>d Zr</i>	<i>1999 to 9999</i>	<i>00</i>
Digital display value (span)	<i>d SP</i>	<i>1999 to 9999</i>	<i>1000</i>
Decimal point position	<i>d Pt</i>	4th digit to 2nd digit, none	<i>8888</i>
LL alarm setpoint	<i>LLRS</i>	<i>1999 to 9999</i>	<i>100</i>
LL trip action	<i>LLtR</i>	<i>Hi, GH/ LoY</i>	<i>LoY</i>
LL deadband	<i>LLdb</i>	<i>0 to 9999</i>	<i>1</i>
LL coil at alarm	<i>LLCR</i>	<i>EnrG/dEnG</i>	<i>EnrG</i>
LL ON delay time	<i>LLdL</i>	<i>0 to 999</i>	<i>0</i>
L alarm setpoint	<i>L RS</i>	<i>1999 to 9999</i>	<i>300</i>
L trip action	<i>L tR</i>	<i>Hi, GH/ LoY</i>	<i>LoY</i>
L deadband	<i>L db</i>	<i>0 to 9999</i>	<i>1</i>
L coil at alarm	<i>L CR</i>	<i>EnrG/dEnG</i>	<i>EnrG</i>
L ON delay time	<i>L dL</i>	<i>0 to 999</i>	<i>0</i>
H alarm setpoint	<i>H RS</i>	<i>1999 to 9999</i>	<i>700</i>
H trip action	<i>H tR</i>	<i>Hi, GH/ LoY</i>	<i>Hi, GH</i>
H deadband	<i>H db</i>	<i>0 to 9999</i>	<i>1</i>
H coil at alarm	<i>H CR</i>	<i>EnrG/dEnG</i>	<i>EnrG</i>
H ON delay time	<i>H dL</i>	<i>0 to 999</i>	<i>0</i>
HH alarm setpoint	<i>HHRS</i>	<i>1999 to 9999</i>	<i>900</i>
HH trip action	<i>HHtR</i>	<i>Hi, GH/ LoY</i>	<i>Hi, GH</i>
HH deadband	<i>HHdb</i>	<i>0 to 9999</i>	<i>1</i>
HH coil at alarm	<i>HHCR</i>	<i>EnrG/dEnG</i>	<i>EnrG</i>
HH ON delay time	<i>HHdL</i>	<i>0 to 999</i>	<i>0</i>
P coil at alarm	<i>P CR</i>	<i>EnrG/dEnG</i>	<i>EnrG</i>
Power ON delay	<i>PYdL</i>	<i>0 to 999</i>	<i>5</i>
Display refreshing rate	<i>dPrF</i>	<i>00 to 999</i>	<i>00</i>
Filter type	<i>FLtr</i>	<i>RuG/ dLY</i>	<i>RuG</i>
Moving average	<i>RuGn</i>	<i>RoFF/R 2/R 4/R 8/R 16</i>	<i>RoFF</i>
Filter time constant	<i>dLYn</i>	<i>0 to 30</i>	<i>0</i>
Low-end cutout	<i>doUt</i>	<i>d on/doFF</i>	<i>doFF</i>
Low-end cutout value	<i>doRL</i>	<i>00 to 999</i>	<i>00</i>
Changing zero position of bargraph	<i>ZrPS</i>	<i>0 to 25</i>	<i>0</i>
Brightness	<i>brt</i>	<i>1/ 2/ 3/ 4/ 5/ 6/ 7</i>	<i>7</i>
Setting initialization	<i>rSt</i>	<i>roFF/r on</i>	<i>roFF</i>
Version indication (MAIN)		Vx.xx	-
Version indication (DISP)		Vx.xx	-

• Display pattern

The display pattern of the bargraph can be set.

SETTING	MEANING	DEFAULT VALUE
$\overline{P}R\overline{L}1$	Pattern 1	$\overline{P}R\overline{L}1$
$\overline{P}R\overline{L}2$	Pattern 2	
$r\overline{E}d$	Red (single color)	
$\overline{A}m\overline{B}$	Amber (single color)	
$\overline{G}r\overline{N}$	Green (single color)	

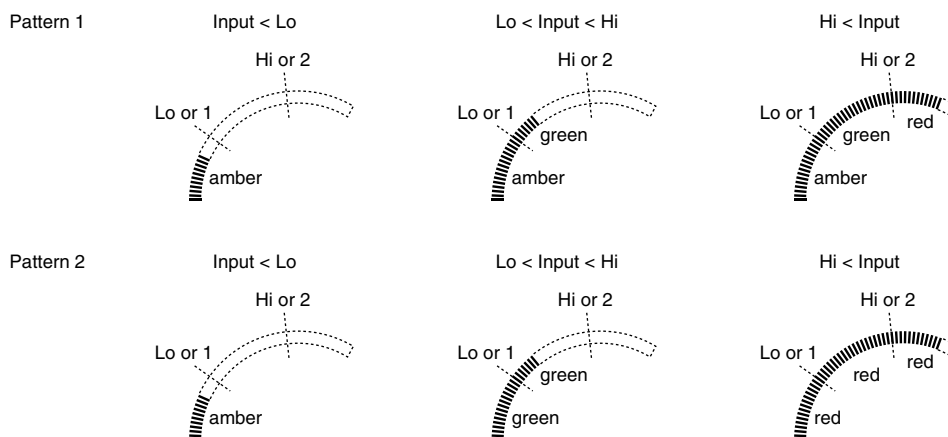

• Bargraph display value (zero)

Set 0% value of the signal inputted to the device.

Although 0% signal is used as an example in the following steps, there are no restrictions on the input range.

1. Input 0% signal.
2. Press MODE button for more than 3 seconds to switch to the setting mode.
3. Press MODE button at the [Bargraph display value (zero)] parameter. The parameter name blinks.
4. Press MODE button again, then the parameter name turns on. The setting is complete.

• Bargraph display value (span)

Set 100% value of the signal inputted to the device.

Although 100% signal is used as an example in the following steps, there are no restrictions on the input range.

1. Input 100% signal.
2. Press MODE button for more than 3 seconds to switch to the setting mode.
3. Press MODE button at the [Bargraph display value (span)] parameter. The parameter name blinks.
4. Press MODE button again, then the parameter name turns on. The setting is complete.

• Digital display value (zero)

Set the seven-segment display value for [Bargraph display value (zero)].

SETTING RANGE	DEFAULT VALUE
$\overline{1}999$ to 9999	00

Set as [Digital display value (zero)] < [Digital display value (span)].

• Digital display value (span)

Set the seven-segment display value for [Bargraph display value (span)].

SETTING RANGE	DEFAULT VALUE
$\overline{1}999$ to 9999	1000

Set as [Digital display value (zero)] < [Digital display value (span)].

• Decimal point position

Set the decimal point position of the seven-segment display value in measuring mode.

SETTING	MEANING	DEFAULT VALUE
8888	No decimal point	1 decimal place
888.8	1 decimal place	
88.88	2 decimal places	
8.888	3 decimal places	

The decimal point position of 4-digit display values can be set.

• LL / L / H / HH alarm setpoint

Set threshold of each alarm.

SETTING RANGE	DEFAULT VALUE
1999 to 9999	LL 100
	L 300
	H 700
	HH 900

This setting is for [digital display value (zero)] and [digital display value (span)].

Set as LL < L < H < HH.

The decimal point position setting is applied.

When the display pattern is pattern 1 or 2, color changes according to the L/H alarm setpoint.

If a value exceeding the digital display value (zero) and (span) is set, [----] is displayed, and the alarm is disabled.

In this case, alarm setting parameters other than the alarm setpoint are not displayed.

• LL / L / H / HH trip action

Set the alarm direction to Hi or Lo.

SETTING	MEANING	DEFAULT VALUE
H, GH	Hi	LL, L Lo
Lo	Lo	H, HH H, GH

In case of Hi, the alarm turns ON when the display value exceeds the alarm setpoint.

In case of Lo, the alarm turns ON when the display value falls below the alarm setpoint.

• LL / L / H / HH deadband

Set the deadband at which the alarm turns OFF.

SETTING	DEFAULT VALUE
0 to 9999	1

The deadband means how many counts are set to the alarm setpoint whose decimal point is ignored.

For example, when the digital display value (zero) and (span) is 100.0 to 500.0, and the alarm setpoint is 300.0, and you want to set 1% deadband, the span of the digital display value whose decimal point is ignored is 4000. So set the deadband to 40.

With this setting, the alarm turns off when the seven-segment value falls below 296.0.

• LL / L / H / HH coil at alarm

Set the alarm output logic.

When [de-energized] is set, the logic is inverted.

SETTING	MEANING	DEFAULT VALUE
Enr	Energized	Enr
dEn	De-energized	

• LL / L / H / HH ON delay time

Set the alarm operation delay time in seconds.

SETTING	DEFAULT VALUE
0 to 999 (sec.)	0

• P coil at alarm

Set output logic of P contact.

When [de-energized] is set, the logic is inverted.

SETTING	MEANING	DEFAULT VALUE
Enr	Energized	Enr
dEn	De-energized	

• Power ON delay

Set the alarm operation delay time upon power-on in seconds.

SETTING	DEFAULT VALUE
0 to 999 (sec.)	5

• Display refreshing rate

Set the display refreshing rate of the bargraphs and seven-segment displays in seconds.

SETTING	DEFAULT VALUE
00 to 999 (sec.)	00

When the display refreshing rate is 0.0, the display is refreshed every 50 msec.

• Filter type

Select [moving average output] or [first order lag].

SETTING	MEANING	DEFAULT VALUE
MOV	Moving average output	MOV
OLG	First order lag	

• Moving average

When the filter type is first order lag, this parameter is not displayed.

SETTING	MEANING	DEFAULT VALUE
MOV	No moving average	MOV
M 2	Moving average with 2 samples	
M 4	Moving average with 4 samples	
M 8	Moving average with 8 samples	
M 16	Moving average with 16 samples	

• Filter time constant

Set time constant of the first order lag in seconds.

When the filter type is moving average output, this parameter is not displayed.

SETTING	DEFAULT VALUE
0 to 30 (sec.)	0

The first order lag is applied at the set time.

If 0 is set, moving average is not performed.

The time constant means the time it takes to follow up to approx. 63% when the input changes from 0% to 100%.

• Low-end cutout

Set ON or OFF of low-end cutout.

SETTING	MEANING	DEFAULT VALUE
don	Low-end cutout ON	doff
doff	Low-end cutout OFF	

• Low-end cutout value

Set the low-end cutout value by the percent.

When the low-end cutout is OFF, this parameter is not displayed.

SETTING	DEFAULT VALUE
00 to 999 (%)	00

When the input falls below the low-end cutout value, the value set in [digital display value (zero)] can be displayed.

• Changing zero position of bargraph

Set the zero position of the bargraph by the dot.

SETTING	DEFAULT VALUE
0 to 25 (0 to 50%)	0

The bargraph consists of 51 dots.

So when 25 is set, the zero position is set to 50% position of the normal range.

The bargraph displays the zero position as the midpoint.

For example, in case that an input signal is 0 to 10 V DC, it is possible to display -10 to 0 to 10 V (-100 to 0 to 100%).

However, values below 0% are out of conformance range.

• Brightness

Adjust the brightness of the screen.

SETTING	DEFAULT VALUE
1 (dark) to 7 (bright)	1 7

• Setting initialization

Settings are initialized.

SETTING	MEANING
OFF	The initialization is not performed.
ON	The initialization is performed.

Follow the steps below.

1. Press MODE button for more than 3 seconds to switch to the setting mode.
2. Press MODE button at the [Setting initialization] parameter. [OFF] is displayed.
3. Press UP button or DOWN button.
The display changes to [ON].
4. Press MODE button while [ON] is displayed.
Hold down SET button to switch to the measuring mode.
The setting initialization is complete.

When the settings are initialized, the currently displayed parameters are overwritten with the default values.

Note that the settings are not overwritten with the values specified in the specifications of option (/SET).

• Version indication

The firmware version is displayed.

Press MODE button to display the branch number.

There are two types for version.

When the lowest decimal point is ON, the version of the display unit is indicated.

ERROR MESSAGES

DISPLAY	ERROR MESSAGE	WHAT TO DO
H, H blinking	The input signal exceeds permissible range.	Set the input signal within the permissible range.
L, L blinking	The input signal falls below permissible range.	
.err blinking	Internal data error.	Repair is needed if the display does not recover after the settings are initialized or after turning off and on the power.
9999 or 1999 blinking	The value after scaling is out of the permissible display range.	Set the display value within the permissible range.

■ INPUT AND ERROR CORRELATION (e.g. 1 – 5 V input)

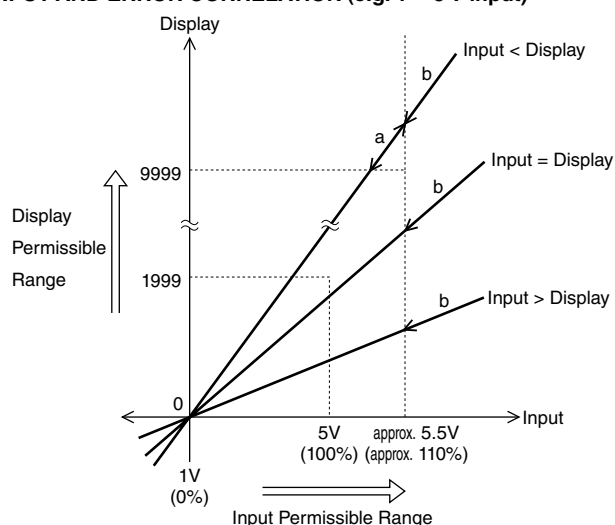

a: 9999 blinking

If the value after scaling is out of the permissible range, the maximum (9999) or minimum (1999) value is blinking.

b: HIGH blinking

If the input signal is out of the permissible range, "HIGH" blinks.

CHARACTER SET

0	1	2	3	4	5	6	7	8	9	-	A	B	C	D	E	F	G	H	I	J	K	L	M	N	O	P	Q	R	S	T	U	V	W	X	Y	Z
0	1	2	3	4	5	6	7	8	9	-	A	b	C	d	E	F	G	H	,	J	K	L	ñ	o	P	q	r	S	t	U	v	y	ü	Y	z	€

WIRING INSTRUCTIONS

■ SCREW TERMINAL

Torque: 0.5 N·m

■ SOLDERLESS TERMINAL

Refer to the drawing below for recommended ring tongue terminal size. Spade tongue type is also applicable.

Applicable wire size: 0.25 to 1.65 mm² (AWG 22 to 16)

Recommended manufacturer: Japan Solderless Terminal
MFG.Co.Ltd, Nichifu Co.,Ltd

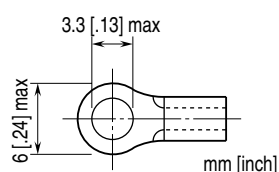

LIGHTNING SURGE PROTECTION

We offer a series of lightning surge protector for protection against induced lightning surges. Please contact us to choose appropriate models.

ALARM TRIP OPERATION

Alarm Trip Operation

Terminal No. in parentheses

• Alarm Output Code 2

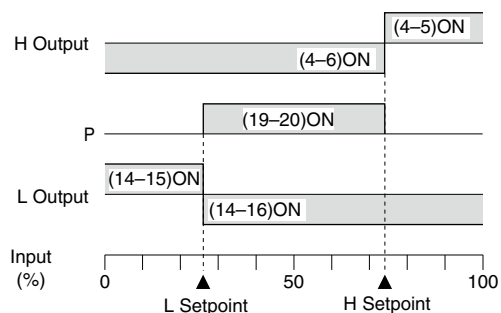

• Alarm Output Code 4

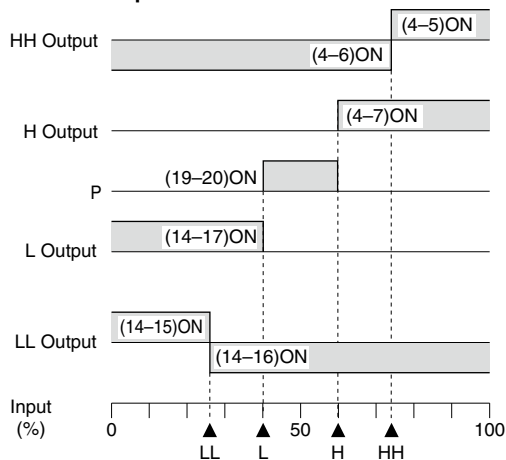

Terminals 4 – 6, 14 – 16 turn on at a loss of power.