

Bargraph Indicators 48N Series
BARGRAPH INDICATING ALARM
(with 4-digit digital meter; thermocouple input)

Model: 48NDT

OPERATING MANUAL

CONTENTS

1. INTRODUCTION	4
1.1 BEFORE USE.....	4
1.2 SAFETY PRECAUTIONS (that must be observed).....	5
1.3 POINTS OF CAUTION.....	7
1.4 COMPONENT IDENTIFICATION.....	9
1.5 INSTALLATION.....	13
1.5.1 EXTERNAL DIMENSIONS	13
1.5.2 INSTALLATION	14
1.5.3 MOUNTING THE UNIT ON A PANEL	15
1.6 WIRING INSTRUCTIONS	16
1.6.1 CAUTION IN WIRING	16
1.6.2 RECOMMENDED SOLDERLESS TERMINAL	16
1.6.3 TERMINAL ASSIGNMENT.....	17
1.6.4 WIRING INPUT SIGNAL.....	17
1.6.5 WIRING ALARM OUTPUTS	18
1.6.6 WIRING POWER	20
1.6.7 ATTACHING/DETACHING TERMINAL BLOCK.....	21
1.6.8 OPENING/CLOSING TERMINAL COVER.....	21
2. BASIC SETTING AND OPERATION	22
2.1 BASIC SETTING	22
2.1.1 FLOW OF INITIAL SETTING	22
2.1.2 MODE TRANSITION.....	23
2.1.3 BASIC OPERATION.....	23
2.1.4 INSTRUCTIONS FOR SETTING OPERATION	23
2.1.5 SHIFT THROUGH PARAMETER ITEMS.....	24
3. SETTING ALARM OUTPUT	26
3.1 SETTING RANGE AND INITIAL SETTING.....	26
3.2 ALARM TRIP AND BARGRAPH COLOR DISPLAY OPERATION.....	27
3.3 OPERATING PROCEDURE	28
4. SETTING ALARM ON DELAY TIME	29
4.1 OPERATING PROCEDURE.....	30
5. AVERAGING INPUT	31
5.1 OPERATING PROCEDURE.....	32
6. ADJUSTING BRIGHTNESS OF DISPLAY	33
6.1 OPERATING PROCEDURE.....	34

7. SETTING DIGITAL INDICATOR.....	35
7.1 DIGITAL INDICATOR SETTING	35
7.2 SETTING PROCEDURES OF DIGITAL INDICATOR.....	35
7.3 OPERATING PROCEDURE FOR SETTING DIGITAL INDICATOR ZERO ADJUSTMENT	36
7.4 OPERATING PROCEDURE FOR SETTING DIGITAL INDICATOR SPAN ADJUSTMENT .	37
7.5 OPERATING PROCEDURE FOR SETTING DECIMAL POINT POSITION	38
8. USER CALIBRATION.....	39
8.1 BARGRAPH ZERO/SPAN ADJUSTMENT	40
8.2 OPERATING PROCEDURE OF BARGRAPH ZERO ADJUSTMENT	41
8.3 OPERATING PROCEDURE OF BARGRAPH SPAN ADJUSTMENT.....	42
8.4 RESETTING CALIBRATION DATA TO FACTORY-SET VALUES	43
9. REPLACEMENT OF SCALE PLATE	44
9.1 DETACHING SCALE PLATE	44
9.2 ATTACHING SCALE PLATE	44
10. INSPECTION AND CLEANING.....	45
11. APPENDICES.....	46
11.1 SPECIFICATIONS	46
11.2 MODEL NUMBERING.....	49
11.3 PARAMETER LIST	50

1. INTRODUCTION

1.1 BEFORE USE....

Thank you for choosing us. Before use, please check the contents of the package.



■ PACKAGE CONTENTS

The package should include the following items.

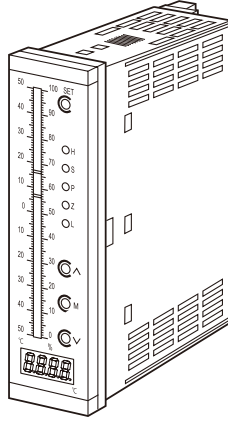
- Bargraph indicating alarm

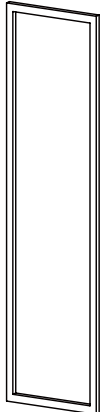
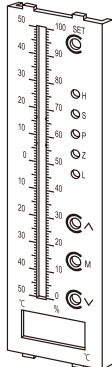

• Accessories

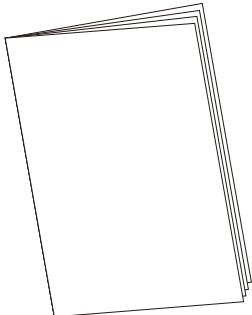
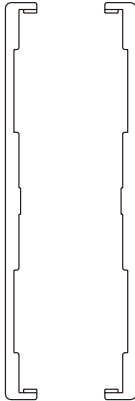
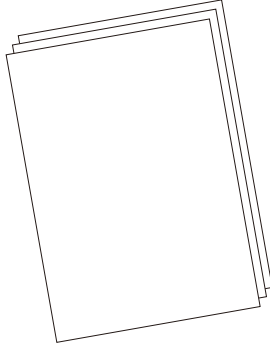
<p>Mounting bracket (2)</p> 	<p>Watertight packing (1)</p> 	<p>Scale plate (1)</p> 	<p>CJC sensor (1)</p>  <p>(screwed to the input terminals)</p>
<p>Instruction manual</p> 	<p>Bezel (2)</p>  <p>The size of bezels differs depending on the selected option code.</p>	<p>Ordering Information Sheet</p>  <p>Included when the ex-factory setting is selected as option.</p>	

■ MODEL NO.

Confirm Model No. marking on the product to be exactly what you ordered.

1.2 SAFETY PRECAUTIONS (that must be observed)

The following signs are used in this manual to provide precautions required to ensure safe usage of the unit. Please understand these signs and graphic symbols, read the manual carefully and observe the precautions given therein.

■ WARNING/CAUTION SIGNS

See below for the degree of safety hazard or damage which may occur due to wrong usage of the unit in spite of the sign.

	WARNING	Indicates a potentially hazardous situation which, if not avoided, may result in serious injury or death.			
	CAUTION	Indicates a potentially hazardous situation which, if not avoided, may result in injury or in property damage.			
	Indicates prohibitions.		Indicates mandatory cautions.		Indicates cautions.

WARNING

 CAUTION	For safety, make sure that wiring is performed by qualified personnel only. • Failure to do so may result in a fire, electric shock, or injury.
 CAUTION ELECTRIC SHOCK	Do not touch the terminals while the power is on. • Doing so may result in electric shock.
 MANDATORY CAUTION	Check the connection diagram carefully before wire connection. • Failure to do so may result in malfunction, a fire, or electric shock.
 MANDATORY CAUTION	Provide safety measures outside of the unit to ensure safety in the whole system if an abnormality occurs due to malfunction of the unit or another external factor affecting the unit's operation.
 PROHIBITION TO BE WET	Do not splash water on the unit except for the front panel installed correctly. • Doing so may result in a fire, electric shock, or injury.
 MANDATORY CAUTION	Stop using the unit immediately if smoke, unusual odor, and/or abnormal noise come(s) from it. • Using the unit continuously may result in a fire or electric shock.
 MANDATORY CAUTION	Stop using the unit if it is dropped or damaged. • Using the unit continuously may result in a fire or electric shock.
 MANDATORY CAUTION	Tighten the terminal blocks and terminal block screws with a specified torque. • Excessive fastening may result in damage of the screws and loose screws may occasionally result in ignition.
 PROHIBITION	Do not throw the unit into the fire. • Doing so may result in rupture of the electronic component.



CAUTION



PROHIBITION
TO DISCOMPOSE

Never discompose or remodel the unit.

- Doing so may result in electric shock, malfunction, or injury.



PROHIBITION

Do not connect or remove the unit while its power is on.

- Doing so may result in, electric shock, malfunction, or injury.



MANDATORY
CAUTION

Do not allow chips or wire scraps to enter the unit in machining screws or wiring.

- Doing so may result in malfunction of the unit.



MANDATORY
CAUTION

Make sure to attach the terminal cover.

- Failure to do so may result in electric shock.



PROHIBITION

Do not pull the wires connecting to the unit.

- Doing so may result in electric shock, damage of the unit, or injury.



PROHIBITION

Do not use the unit in an atmosphere where combustible gas is present.

- Doing so may result in inflammation, ignition, or smoke.



PROHIBITION

Do not cover the ventilation slits with cables, etc.

- Doing so may result in malfunction or heating.
-

1.3 POINTS OF CAUTION

■ CONFORMITY WITH EU DIRECTIVES OR UK LEGISLATION

- This equipment is suitable for Pollution Degree 2, Measurement category II (output, transient voltage 2500 V) and Installation Category II (transient voltage 2500 V).
Reinforced insulation (input to output to power: 300 V) is provided.
Prior to installation, confirm that the insulation class of this unit satisfies the system requirements.
- The equipment must be mounted on a panel surface appropriately so that the operator will not erroneously touch the terminal block.
- Attach a noise filter to the power cable. TDK-Lambda Noise Filter Model RSAN-2006 or equivalent is recommended.
- The equipment must be installed such that appropriate clearance and creepage distances are maintained to conform to CE or UKCA requirements. Failure to observe these requirements may invalidate the CE or UKCA conformance.
- Our products conforming to the EU Directives or UK legislation conform to the standards required based on the premise that they are built into various equipment, apparatus, or control panels and used.
The EMC performance depends on the configuration, wiring, or arrangement of the equipment, apparatus, and control panels you build. Therefore, it is your responsibility that such equipment, apparatus, and control panels conform to the CE or UKCA Marking as a whole.

CAUTION

This product conforms to the EMC Directive for electrical and electronic apparatus intended for use in industrial environments. For use in residential environments, the user is requested to take appropriate measures to prevent possible radio interference.

■ ENVIRONMENT

Install the unit within the installation specifications.

- Indoors use.
- Environmental temperature must be within -5 to +55°C (23 to 131°F) with relative humidity within 30 to 90% RH without condensing.
- Altitude up to 2000 meters.
- Provide sufficient space around the unit for heat dissipation.
- Mount the unit to a panel with a thickness of between 1.6 and 8 mm.
- Install the unit in a well-ventilated place in order to prevent internal temperature rise.
- Refer to "■ PANEL CUTOUT" on page 14 to install multiple units. When mounting the unit with other equipment side by side, provide sufficient space between them, according to the dimensions specified for the panel cutout.
- Do not use the unit under the following environments:
 - Where the unit is exposed to direct sunlight, rain or wind. (The unit is not designed for outdoor use.)
 - Where condensation may occur due to extreme temperature changes.
 - Where corrosive or flammable gas is present.
 - Where heavy dust, iron powder, or salt is present in the air.
 - Where organic solvent such as benzene, thinner, and alcohol or strong alkaline materials such as ammonia and caustic soda may attach to the unit, or where such materials are present in the air.
 - Where the unit is subject to continuous vibration or physical impact.
 - Where there are high-voltage lines, high-voltage equipment, power lines, power equipment, equipment with transmission unit such as a ham radio equipment, and/or equipment generating large switching surges around the unit.

■ WIRING

- In order to prevent potential electric shock, wire the unit after turning off the power supply and making sure that the power is not supplied to the cable.
- In order to enable the operator to turn off the power input immediately, install a switch or a circuit breaker with proper marking according to the relevant requirements in IEC 60947-2.
- Be sure to confirm the name and polarity of each terminal before wiring to the terminal block.
- Do not connect anything to unused terminals.
- Be sure to attach the terminal cover to prevent electric shock.

■ HANDLING CAUTIONS

- The unit is designed to function as soon as power is supplied, however, a warm up for 10 minutes is required for exerting full performance as described in the data sheet.
- Use the unit within the noted supply power voltage and rated load.
- Clean the surface of the unit with wet soft cloth.
Do not use organic solvent such as benzine, thinner, or alcohol. Doing so may result in deformation or discoloration of the unit.
- When abnormality is found such as smoke, unusual odor, or abnormal noise coming from the unit, immediately cut the power supply and stop using the unit.

■ TO ENSURE DUSTPROOF AND WATERPROOF (DEGREE OF PROTECTION IP65)

To ensure dustproof and waterproof for the front panel of the unit, follow the conditions below.

- Observe the designated panel cutout size (W31.5 × H138 mm) specified by us.
- Make sure to mount each unit singly.
Clustered mounting does not conform to the degree of protection IP65.
- When installing the unit on the panel, interpose the accompanying watertight packing between them.
- Insert the unit into the panel cutout, and fasten both mounting brackets tightly until they hit the panel.
- After installation, confirm that there are no following abnormalities.
 - The packing is contorted.
 - There are some spaces between the front panel of the unit and the panel.
 - The packing is running off the edge.
 - The packing is torn or broken.
 - There are foreign objects caught between the packing and the unit or the panel.

1.4 COMPONENT IDENTIFICATION

■ FRONT VIEW

The front panel differs according to the alarm output code and the bar LED color code.

Refer to "■ BUTTONS" and "■ LED INDICATORS" on page 11 for the detailed functions of the respective buttons and LEDs.

• DISPLAY ONLY

ALARM OUTPUT CODE: None

BAR LED COLOR CODE: R/Y/G/B

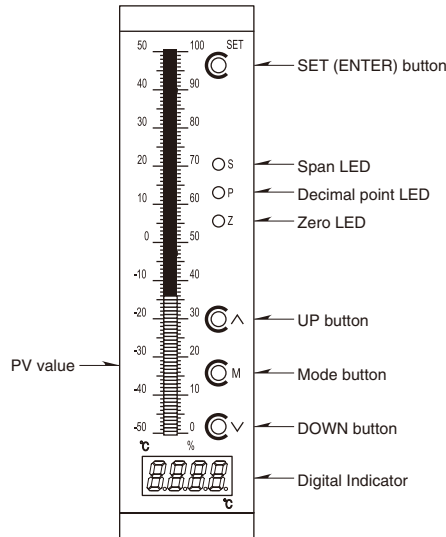

• DISPLAY ONLY PATTERN 1 OR 2

ALARM OUTPUT CODE: None

BAR LED COLOR CODE: Multi-color, pattern 1 or 2

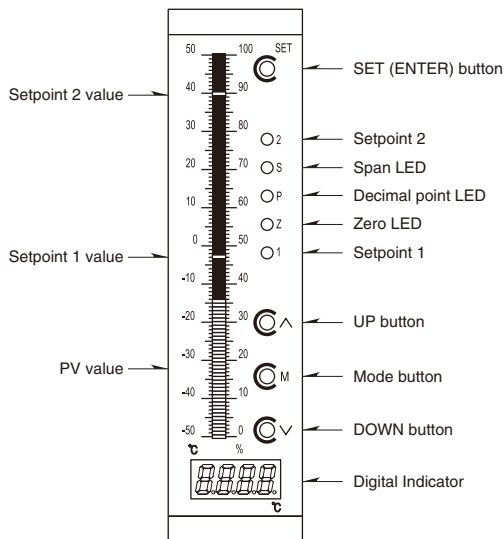

● Bar Color Pattern

Pattern 1 (Bar LED color code: 1)

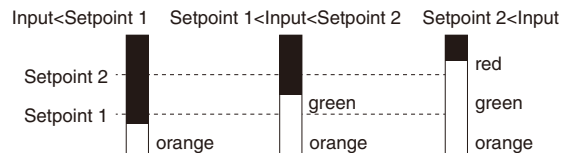

Pattern 2 (Bar LED color code: 2)

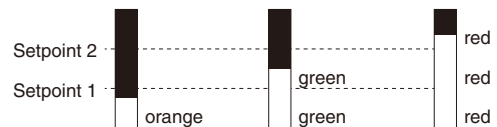

• 2 POINTS ALARM
ALARM OUTPUT CODE: 2

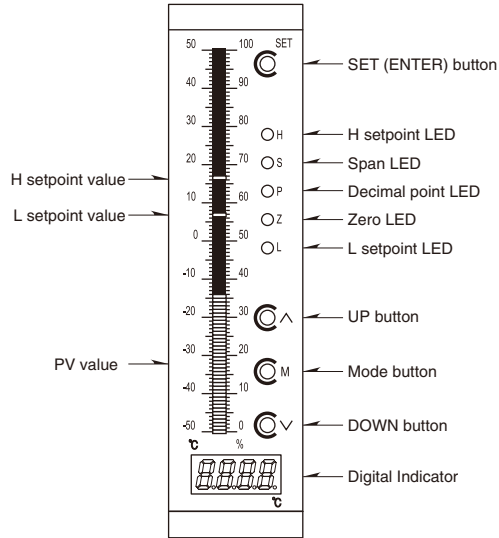

● Bar Color Pattern

Pattern 1 (Bar LED color code: 1)

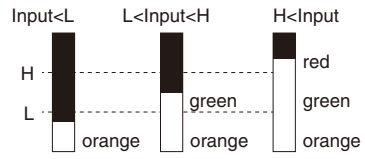

Pattern 2 (Bar LED color code: 2)

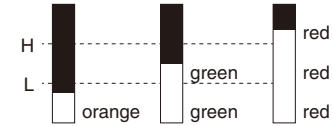

• 4 POINTS ALARM
ALARM OUTPUT CODE: 4

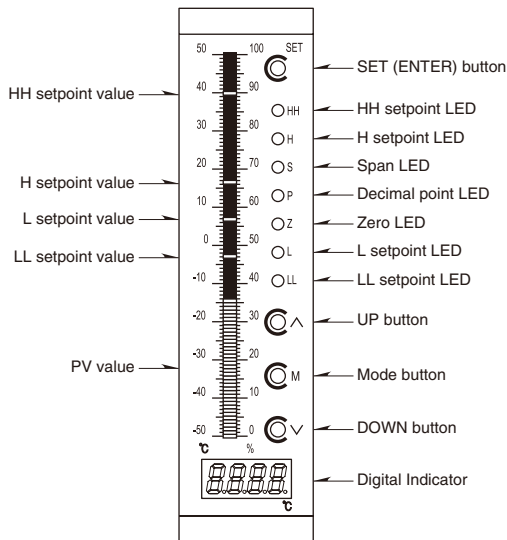

● Bar Color Pattern



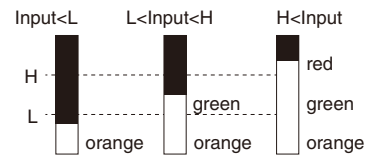

Pattern 1 (Bar LED color code: 1)

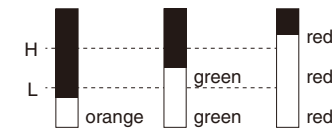

Pattern 2 (Bar LED color code: 2)



■ BUTTONS

BUTTON	NAME	FUNCTION (the button is used to:)
	SET (ENTER) button	<ul style="list-style-type: none"> • Save the setting values and adjustment values. • Reset to factory setting.
	UP button	<ul style="list-style-type: none"> • Change the setting values. • Shift to the advanced setting items.
	Mode button	<ul style="list-style-type: none"> • Shift to Setting/Adjustment Mode. • Shift among the setting items.
	DOWN button	<ul style="list-style-type: none"> • Change the setting values. • Shift to the advanced setting items. • Reset to factory setting.

■ LED INDICATORS

LED	NAME	COLOR	FUNCTION
HH	HH limit LED	red	<ul style="list-style-type: none"> • Turns on when HH alarm is tripped (4-point alarm only). • Blinks while setting HH setpoint value or HH ON delay time.
H	H limit LED	red	<ul style="list-style-type: none"> • Turns on when H alarm is tripped (2-point and 4-point alarm). • Blinks while setting H setpoint value or H ON delay time (2-point and 4-point alarm).
2	Setpoint 2 LED	red	<ul style="list-style-type: none"> • Turns on when the input signal exceeds the Setpoint 2 value (display only pattern 1 or 2 only). • Blinks while setting Setpoint 2 value (display only pattern 1 or 2 only).
S	Span LED	amber	<ul style="list-style-type: none"> • Blinks while setting digital display span adjustment. • Turns on while setting bargraph span adjustment.
P	Decimal point LED	amber	<ul style="list-style-type: none"> • Blinks while setting the decimal point position, No. of moving average samples, brightness adjustment, or resetting to factory setting.
Z	Zero LED	amber	<ul style="list-style-type: none"> • Blinks while setting digital display zero adjustment. • Turns on while setting bargraph zero adjustment.
1	Setpoint 1 LED	green	<ul style="list-style-type: none"> • Turns on when the input signal exceeds the Setpoint 1 value (display pattern 1 or 2 only). • Blinks while setting Setpoint 1 value (display pattern 1 or 2 only).
L	L limit LED	green	<ul style="list-style-type: none"> • Turns on when L alarm is tripped (2-point and 4-point alarm). • Blinks while setting L setpoint value or L ON delay time (2-point and 4-point alarm).
LL	LL limit LED	green	<ul style="list-style-type: none"> • Turns on when LL alarm is tripped (4-point alarm only). • Blinks while setting LL setpoint value or LL ON delay time (4-point alarm only).

■ SPECIFICATIONS AND CONNECTION DIAGRAM

• Right side

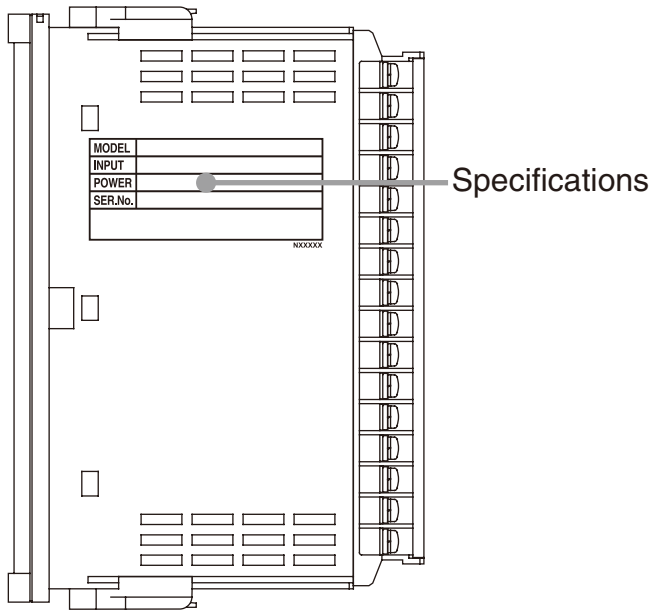

• Rear side

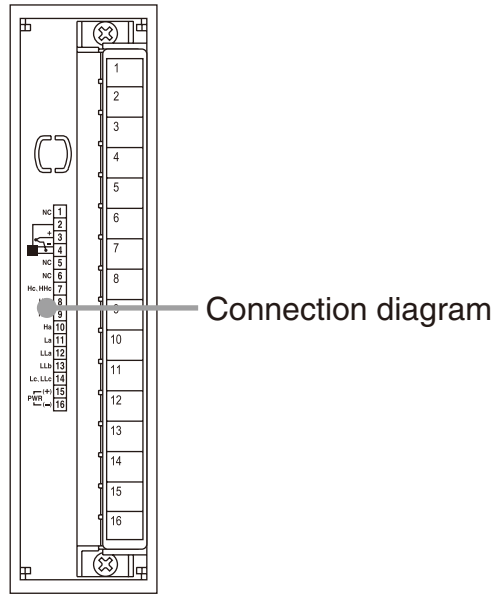

• Left side

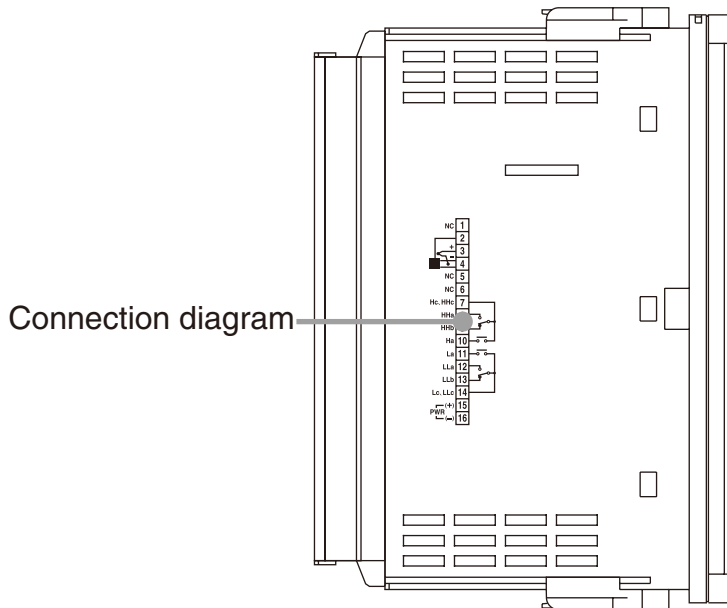

NOTE

- These markings differ depending on the specifications of the ordered product.

1.5 INSTALLATION

1.5.1 EXTERNAL DIMENSIONS

■ **BODY** unit: mm [inch]

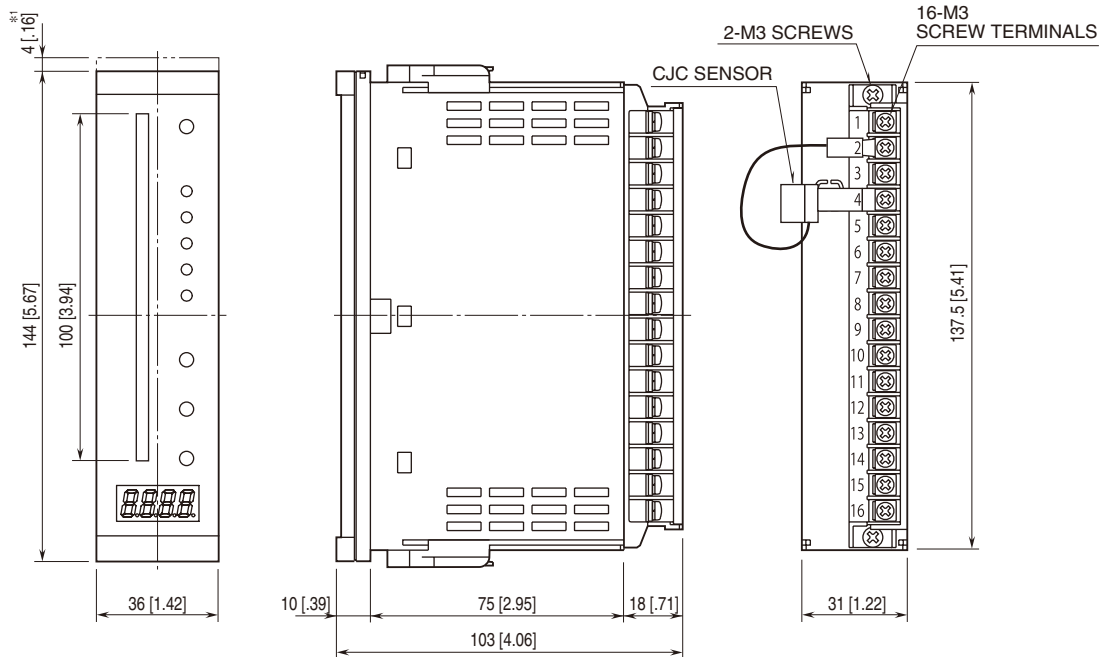

*1. Space required when replacing the scale plate.

■ **BEZEL** unit: mm [inch]

● **STANDARD BEZEL** *2

● **OPTION /D BEZEL** *3

● **OPTION /F BEZEL** *4

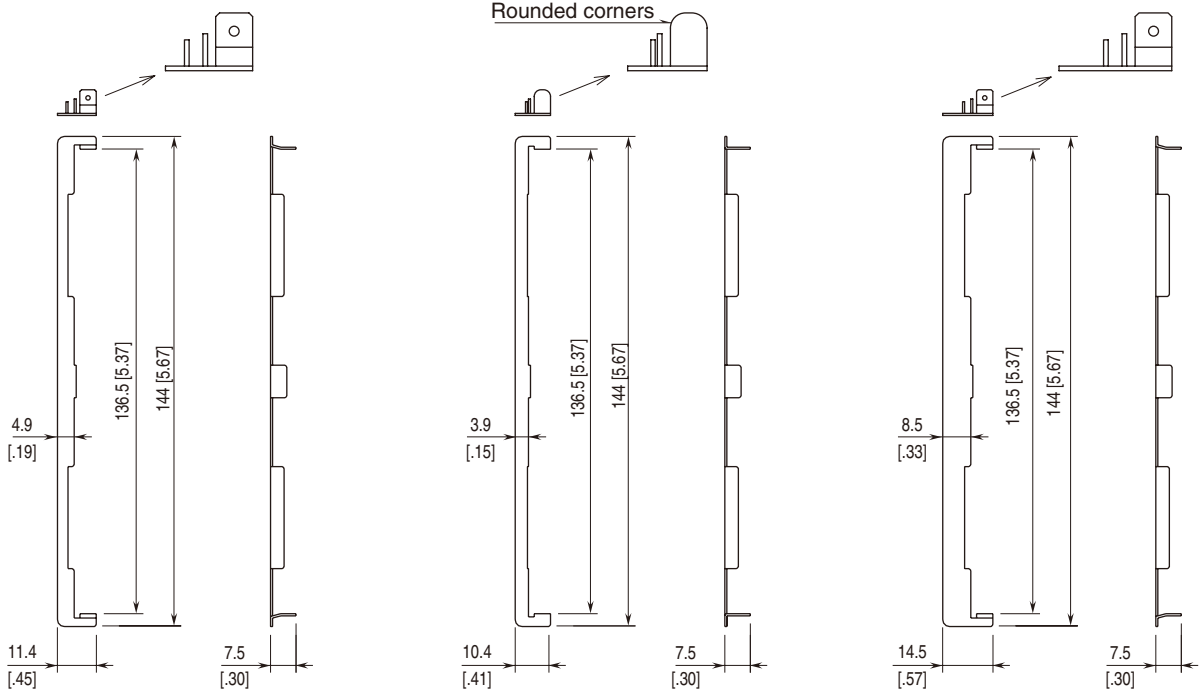

*2. Used for the existing panel cutout of the 48 Series (38 × 139.5 mm).

*3. Used for the existing DIN panel cutout (33 × 138 mm)

*4. Used for the existing panel cutout of Fuji Electric PAJ, PAK, PBA (44 × 138 mm), etc.

1.5.2 INSTALLATION

■ PANEL CUTOUT

● SINGLE MOUNTING (Conforming to IP65)

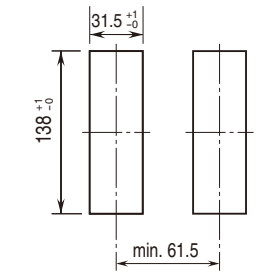

Panel thickness: 1.6 – 8.0 mm

● CLUSTERED MOUNTING (Not conforming to IP65)

unit: mm

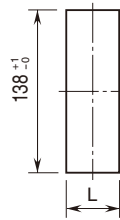

Panel thickness: 1.6 – 8.0 mm

$$L = \{31.5 + 36 \times (N - 1)\} \begin{matrix} +1 \\ -0 \end{matrix}$$

(N : number of units)

- *1. Sufficient space (at least 3 cm high) is necessary both above and below the unit for heat dissipation.
- *2. No bezel is needed when the panel is cut out according to the above dimensions.

■ ATTACHING BEZEL

When replacing units, bezels are used if the panel already has a cutout and its dimensions do not match the specified size by us.

Bezels of the one of the following sizes will be supplied with the unit according to the bezel code specified at ordering.

BEZEL CODE	DESCRIPTION
Blank	Bezels for the 48 Series panel cutout (size: 38 × 139.5 mm)
/D	Bezels for DIN panel cutout (size: 33 × 138 mm)
/F	Bezels for Fuji Electric PAJ, PAK, PBA panel cutout (size: 44 × 138 mm)

IMPORTANT

- Bezels are not necessary when newly installing a 48NDT unit on a panel with a cutout of the size (31.5 × 138 mm) specified by us.

For single mounting, attach bezels to both left and right sides of the unit.

For clustered mounting of two or more units, attach one bezel in between the units.

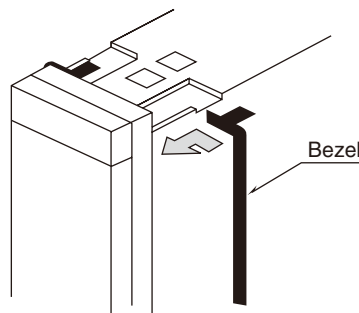

- Single mounting

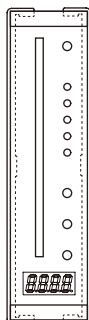

- Clustered mounting (when mounting 3 units)

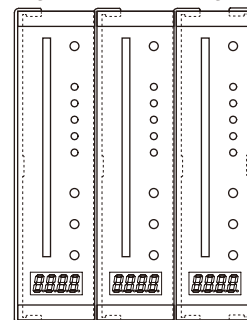

1.5.3 MOUNTING THE UNIT ON A PANEL

1) To remove brackets on the top and bottom of the unit, lift the tab of each bracket and with the tab lifted, pull the bracket toward the terminal block to remove it.

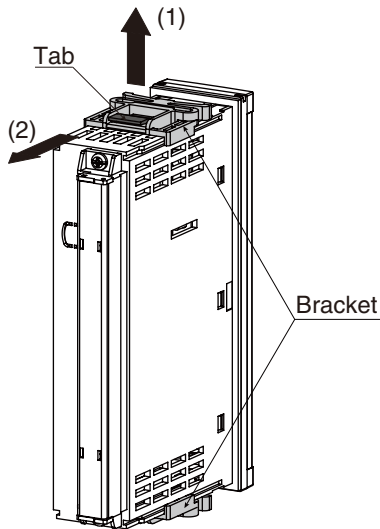

2) Be sure to attach the watertight packing to the unit regardless of with or without the waterproof.

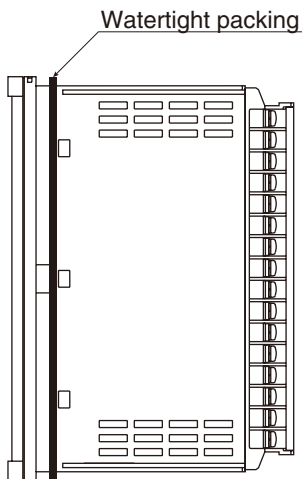

3) Insert the unit into the panel cutout.

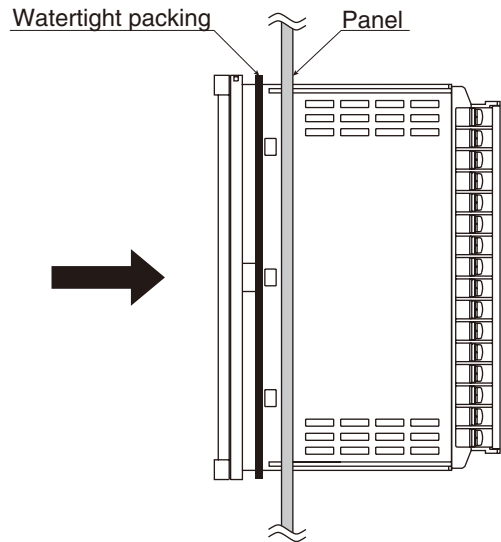

4) Fit the brackets into the fixing grooves on both top and bottom of the unit and slide them along the grooves until they hit the panel.

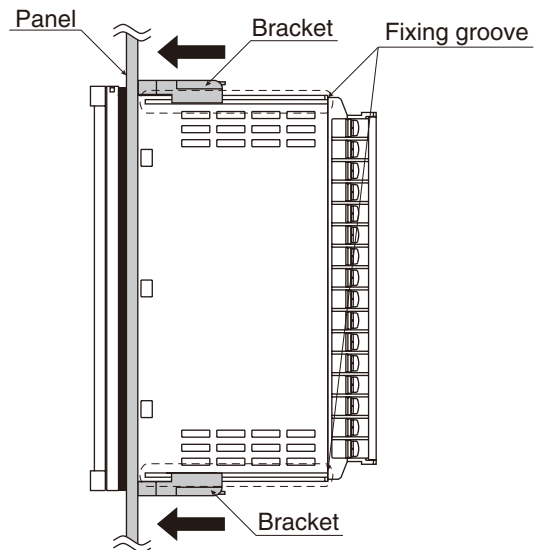

IMPORTANT

- To ensure the degree of protection IP65, confirm that the watertight packing is not twisted, cut, or running off the edge after installation.
- Accompanying bezels are not used when a panel with a cutout of the specified size for 48NDT is used in single mounting or clustered mounting.
- Sufficient space (at least 3 cm high) is necessary both above and below the unit for heat dissipation.

1.6 WIRING INSTRUCTIONS

1.6.1 CAUTION IN WIRING

- For safety, make sure that wiring is performed by qualified personnel only.
- In order to prevent potential electric shock, wire the unit after turning off the power supply and making sure that the power is not supplied to the cable.
- Be sure to confirm the name and polarity of each terminal before wiring.
- Do not connect anything to unused terminals.
- We offer a series of lightning surge protectors for protection against induced lightning surges. Consult us or local representative for details.

1.6.2 RECOMMENDED SOLDERLESS TERMINAL

- Use solderless terminals for M3. Refer to the drawings below.

unit: mm [inch]

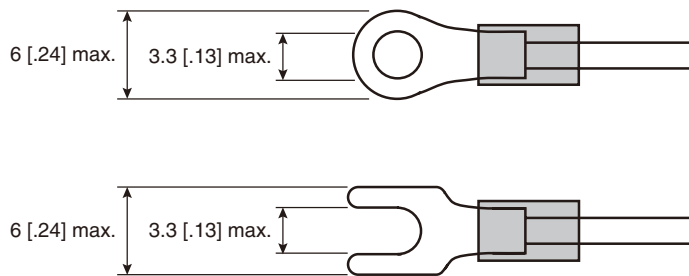

Applicable wire size: 0.25 to 1.65 mm²

Torque: 0.6 N·m

Recommended manufacturer: Japan Solderless Terminal MFG. Co., Ltd., Nichifu Co., Ltd.

IMPORTANT

- Insulated solderless terminals are recommended.
 - When using non-insulated solderless terminals, cover them with insulating caps or tubes.
 - Ring tongue terminals are recommended rather than spade tongue terminals to prevent from coming off.
-

1.6.3 TERMINAL ASSIGNMENT

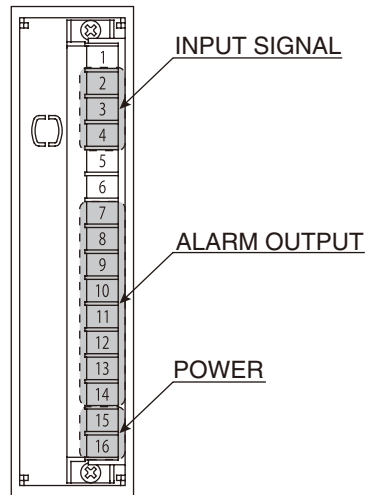

1.6.4 WIRING INPUT SIGNAL

Connect a thermocouple or compensating leadwire.

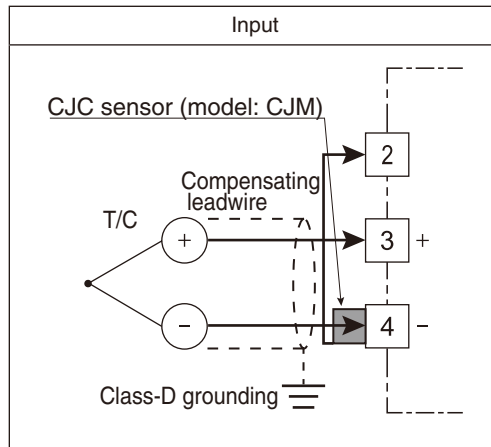

IMPORTANT

- Be sure to confirm the polarity of thermocouple or compensating leadwire when wiring.
- When connecting between the unit and a thermocouple, use compensating leadwire having the same properties as those of the thermocouple.
- Take measures to reduce noise as much as possible, e.g., by using shielded twisted pair wires for the input signal. Ground the input shield to the most stable earth to prevent noise troubles.
- Stabilize the temperature around the terminal block.
DO NOT expose the terminal block to direct air flow from cooling fans or ventilation fans.
- Connect a CJC sensor to Terminals 2 and 4 (CJC sensor is not provided for a B thermocouple).
CJC sensor is not interchangeable. Once the CJC sensor is attached to the unit, DO NOT loosen the Terminal 2 screw to prevent it from being detached from the unit.
- DO NOT connect anything to unused terminals.

IMPORTANT

- CJC sensor is not interchangeable and is marked with a serial number that matches a serial number of the paired unit.
When the terminal block has been removed from the unit or the CJC sensor has been unintentionally detached from the unit, make sure that the CJC sensor and the unit have the identical serial number before reattaching.
Use of an unmatched CJC sensor can cause errors in measurement values.

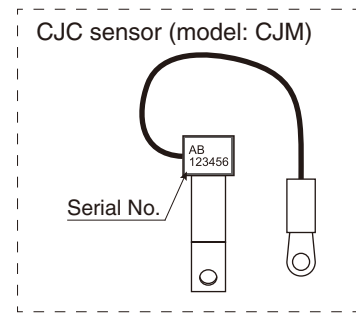

- When reattaching the CJC sensor to the unit, connect the sensor to Terminals 2 and 4 in such a manner that its serial number can be read as shown in the right figure.

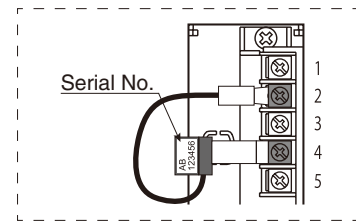

1.6.5 WIRING ALARM OUTPUTS

Two or four alarm contacts are tripped depending on the specified alarm output code.

■ ALARM TRIP OPERATION

Trip action: Terminal numbers in parentheses.

Trip action at power failure: (7 – 9), (13 – 14) ON

Alarm output code 2: 2 points

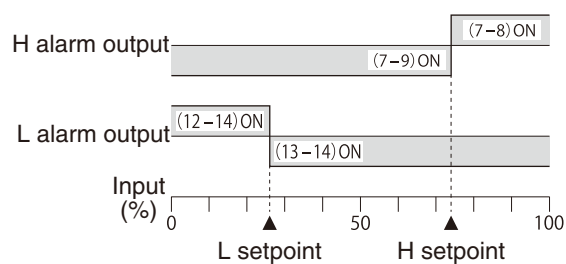

Alarm output code 4: 4 points

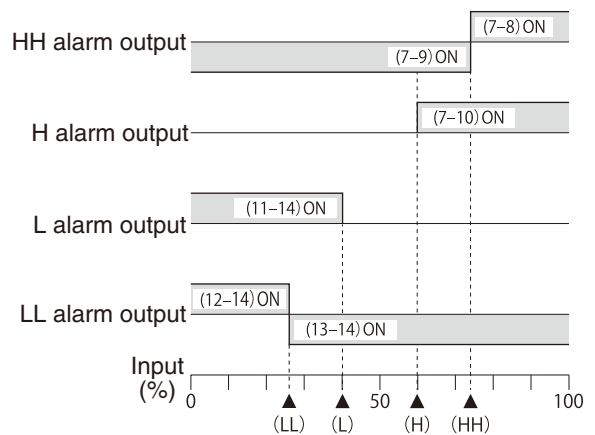

■ ALARM OUTPUT WIRING

IMPORTANT

- Connect load within the specifications.
- The mechanical lifetime of the relays is 5,000,000 operations.
- With inductive load such as an external relay or a motor, insert a CR circuit (for AC or DC power), a diode (for DC power), or a varistor (for AC or DC power) in parallel to protect the contacts and eliminate noise.

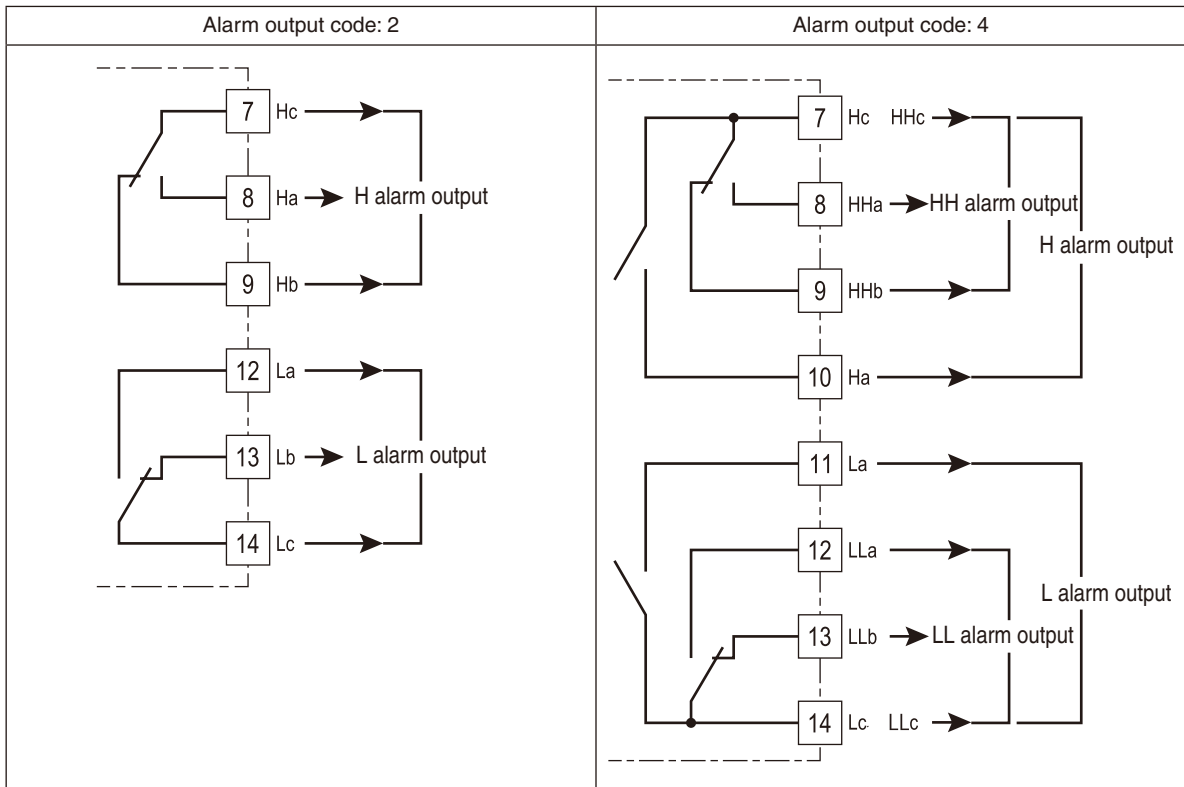

NOTE

Example of contact protection circuit with inductive load

■ DC powered

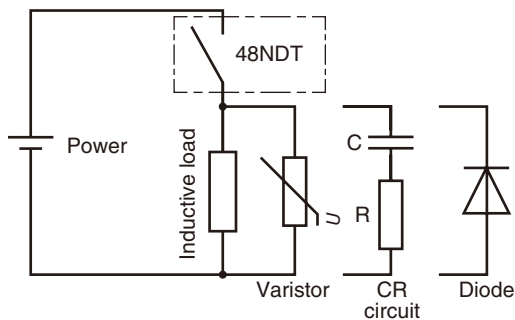

■ AC powered

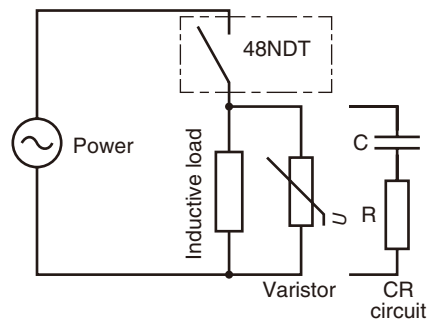

* It is effective to connect a varistor across a load with the supply voltage 24 to 28 V, and across a contact with 100 to 200 V.

1.6.6 WIRING POWER

Connect power according to the power input code.

The power specifications are as shown in the following table.

CODE	RATING	PERMISSIBLE RANGE
M	85 to 264 V AC	85 to 264 V AC, 50/60 Hz approx. 5.5 VA at 100 V approx. 7 VA at 200 V approx. 8 VA at 264 V
M2	100 to 240 V AC	85 to 264 V AC, 50/60 Hz approx. 5.5 VA at 100 V approx. 7 VA at 200 V approx. 8 VA at 264 V
R	24 V DC	±15% approx. 3.5 W

IMPORTANT

- For safety, make sure that wiring is performed by qualified personnel only.
- In order to prevent potential electric shock, wire the unit after turning off the power supply and making sure that the power is not supplied to the cable.
- Use wires as thick as possible and twist them from the end.
- For DC power, confirm the polarity.

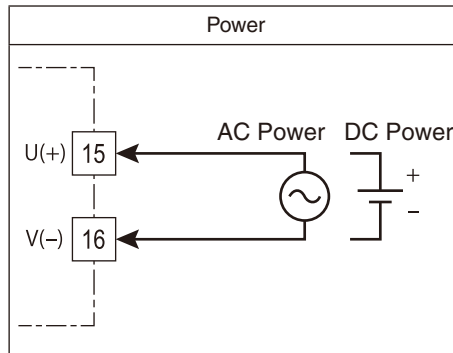

1.6.7 ATTACHING/DETACHING TERMINAL BLOCK

The terminal block has a two-piece structure and is attachable/detachable to/from the unit.
Tighten/loosen two screws uniformly on both sides of the terminal block to attach/detach to/from the unit.

Torque: 0.6 N·m

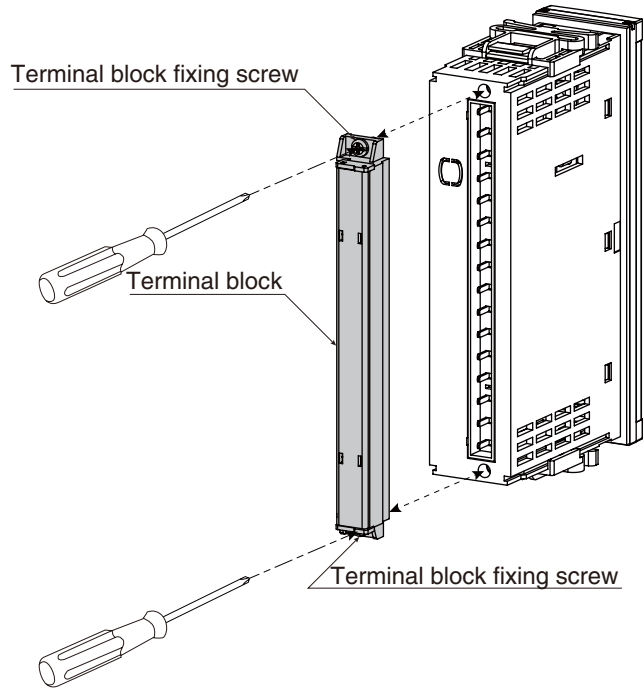

IMPORTANT

- Be sure to interrupt electricity to the power, input, and alarm output before attaching/detaching the terminal block.

1.6.8 OPENING/CLOSING TERMINAL COVER

The terminal cover can be opened/closed easily with fingers.
Be sure to close the terminal cover for safety after wiring.

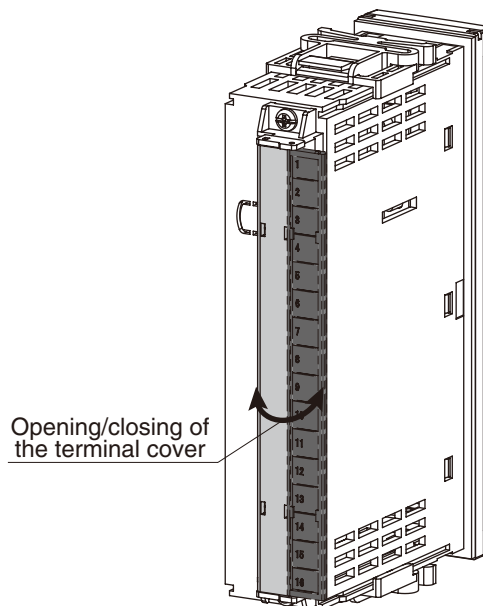

2. BASIC SETTING AND OPERATION

2.1 BASIC SETTING

This section describes the initial setting flow, basic operation, and instructions.

2.1.1 FLOW OF INITIAL SETTING

Before use, take the following steps to perform initial setting.

After the initial setting, set or adjust only required items.

IMPORTANT

- This unit is calibrated at the factory (digital indicator is set according to the ordered specifications). Usually, there is no need for bargraph zero/span adjustment and digital indicator zero/span adjustment. It is only necessary to check whether there is any deviation.

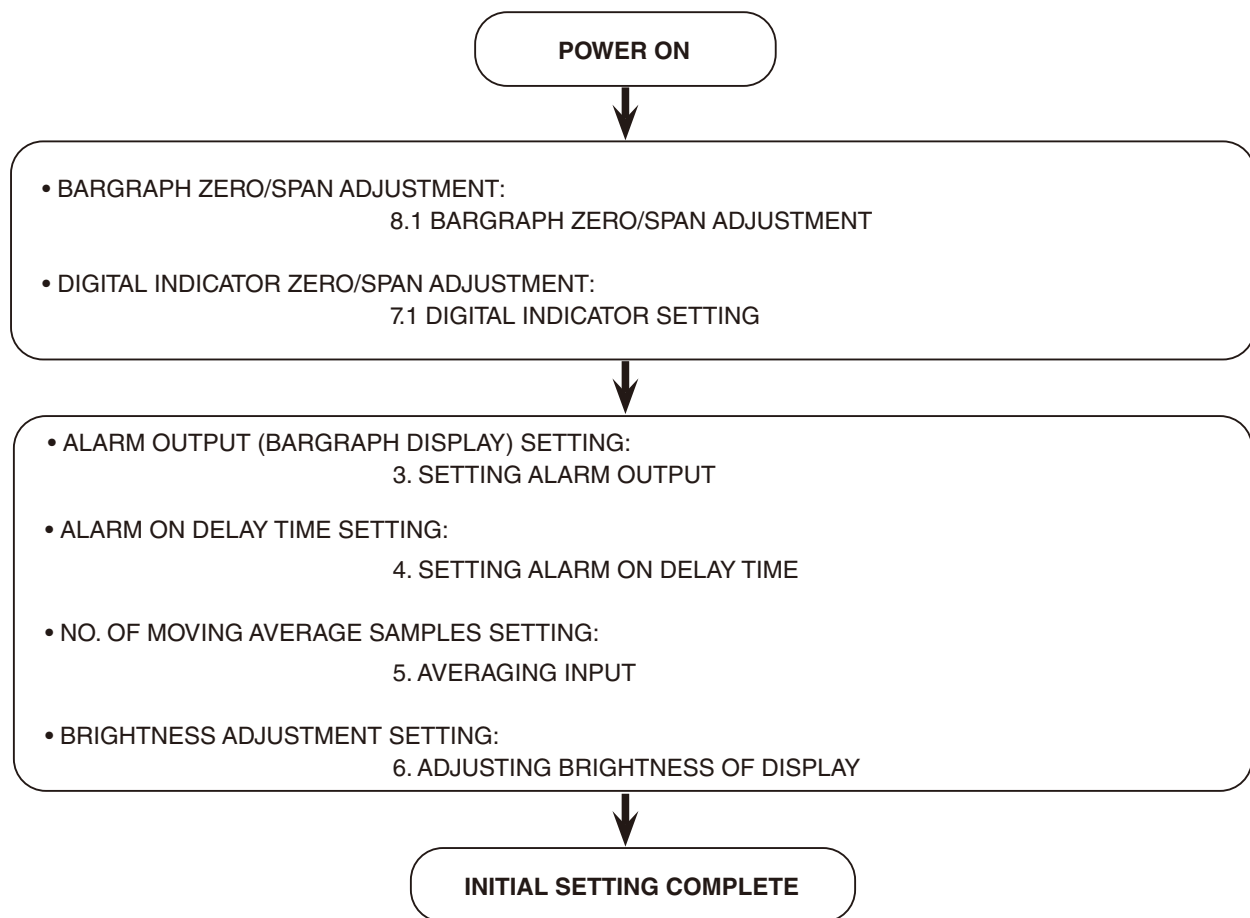

NOTE

- When settings of bargraph zero/span adjustment and digital indicator zero/span adjustment (except decimal point position setting) are saved by **©SET** button, all the alarm setting values (including ones in display-only patterns 1 and 2) are discarded, and alarm ON delay returns to the initial setting value (0.000). Please reconfigure them.
- 0.000 is displayed to indicate that L/LL alarm setpoint (Setting 1) value is below 0% or H/HH alarm setpoint (Setting 2) value is above 100%.

2.1.2 MODE TRANSITION

■ TRANSITION FROM MEASURING MODE

To Setting/Adjustment Mode	Hold down CM button for over 3 seconds to shift to Setting/Adjustment mode.
----------------------------	--

■ TRANSITION TO MEASURING MODE

From Setting/Adjustment Mode	To return to Measuring mode, press CM button several times, or register a value in each setting item by SET button.
------------------------------	---

2.1.3 BASIC OPERATION

Follow the operating procedure below for each setting or adjustment.

- 1) Hold down **CM** button for over 3 seconds in Measuring Mode to shift to Setting/Adjustment Mode.
- 2) Every time **CM** button is pressed, the target setting item shifts to the next.
- 3) Simultaneously press **▲** and **▼** buttons to shift to the advanced setting item.
- 4) Adjust a value with **▲** or **▼** button.
- 5) Press **SET** button to register the value and to return to Measuring Mode.
- 6) To continuously set another item, repeat the procedure from Step 2.
If more than 1 minute has elapsed since the last button operation, the setting item may not shift to the next with **CM** button. In such a case, perform the procedure from Step 1 again.

2.1.4 INSTRUCTIONS FOR SETTING OPERATION

■ SHIFTING FROM MEASURING MODE TO SETTING/ADJUSTMENT MODE

- Alarm output follows the input signal change.
- Alarm LEDs (other than those that blink at setting item transition) turn ON according to the input signal change.
- Setting items in Setting/Adjustment Mode differ depending on the alarm output code and the bar LED color code (in case of display-only).

■ HOLDING DOWN **▲** OR **▼** BUTTON LONGER

- Increases the speed of incrementing or decrementing the value to be set or adjusted.

■ SHIFTING TO ANOTHER ITEM SUBSEQUENTLY IN SETTING/ADJUSTMENT MODE

- In Setting/Adjustment mode, pressing **CM** button within 1 minute after the last button operation can shift to another setting item without holding down the button for over 3 seconds, except when "Reset to Factory Setting" is executed.

■ WHEN NO OPERATION IS PERFORMED FOR A WHILE

- The unit returns to Measuring Mode 1 minute after the button operation has ended, and the value returns to the value before change or adjustment.

■ CANCELLING SET VALUE BEFORE BEING REGISTERED

- Pressing **CM** button in the setting changeable state shifts the item to the next setting item without registering the set value. The value returns to the value before change or adjustment.

2.1.5 SHIFT THROUGH PARAMETER ITEMS

The target item can be shifted among the setting parameter items by the following methods:

- Hold down **CM** button for over 3 seconds to shift the mode to Setting/Adjustment Mode.
The setting parameter item is shifted in the order from No.1 to No. 5 item(s) every time **CM** button is pressed.
From No.5, pressing **CM** button returns to Measuring mode.
Press **CM** button again to shift to No. 1 again.
- To shift from the setting parameter item to its advanced setting parameter item (when available), simultaneously press **CA** button and **CV** buttons.
Every time they are pressed simultaneously, the setting parameter item is shifted to the further advanced one in the order of A, B, C, and back to A.

■ DISPLAY-ONLY

Upper row:	Setting item
Middle row:	LED status
Lower row:	Digital indication example

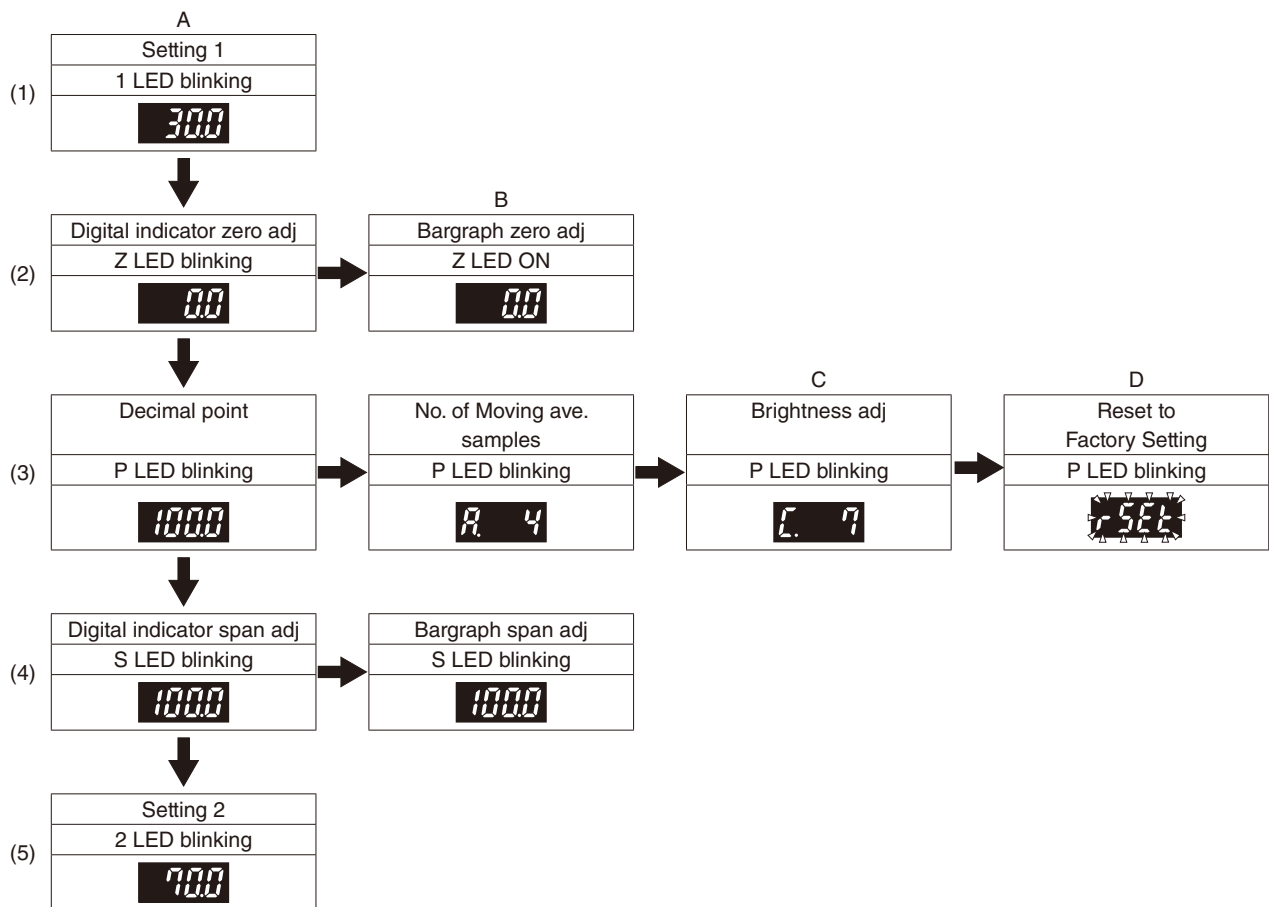

* Item Nos. 1 and 5 are only available for Display patterns 1 and 2.

■ 2-POINT ALARM TRIP/4-POINT ALARM TRIP

Upper row:	Setting item
Middle row:	LED status
Lower row:	Digital indication example

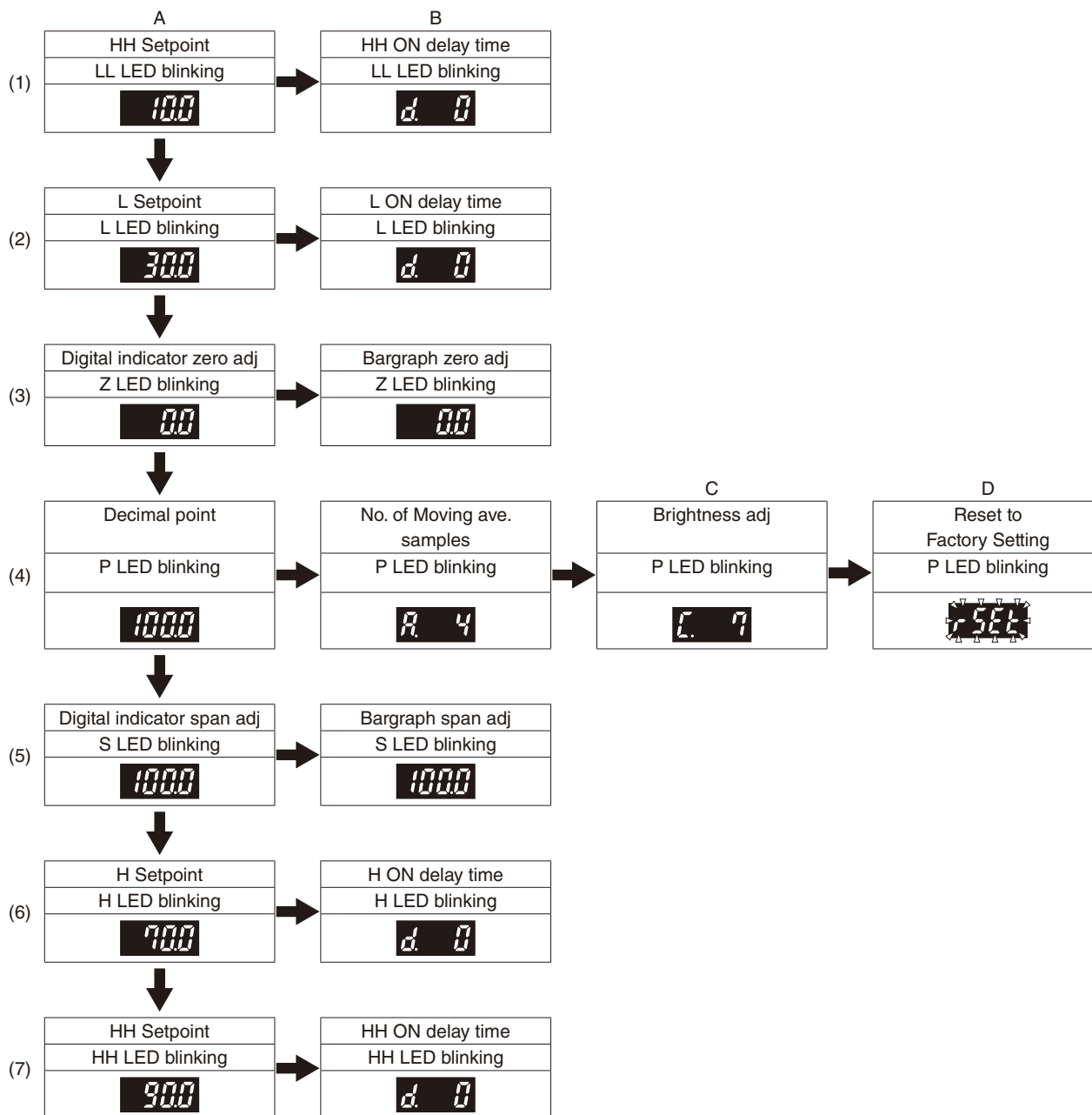

* Item Nos. 1 and 7 are not available for 2-point alarm.

3. SETTING ALARM OUTPUT

Alarm setpoint values can be set within the range set in the digital indicator setting.

For display-only patterns 1 and 2, values at which the bar LED color is changed can be set in the same manner as alarm setpoint values.

3.1 SETTING RANGE AND INITIAL SETTING

The table below shows the setting range and initial setting of each alarm output code and of display-only patterns 1 and 2.

■ 2-POINT ALARM

PARAMETER ITEM	SETTING RANGE	INITIAL SETTING
L setpoint	0% to H setpoint	30%
H setpoint	L setpoint to 100%	70%

■ 4-POINT ALARM

PARAMETER ITEM	SETTING RANGE	INITIAL SETTING
LL setpoint	0% to L setpoint	10%
L setpoint	LL setpoint to H setpoint	30%
H setpoint	L setpoint to HH setpoint	70%
HH setpoint	H setpoint to 100%	90%

■ DISPLAY-ONLY PATTERNS 1 AND 2

PARAMETER ITEM	SETTING RANGE	INITIAL SETTING
Setpoint 1 value	0% to Setpoint 2 value	30%
Setpoint 2 value	Setpoint 1 value to 100%	70%

NOTE

- Each percent value represents a value against the span specified in the digital indicator setting. In actual setting, set an engineering value for the digital indicator.
- Alarm setpoint can also be set using the bar segments of the bargraph, but only in units of 1%. For better setting accuracy, we recommend to perform setting via the digital indicator.
- L (H) alarm setpoint cannot be set to a value that exceeds LL (HH) alarm setpoint. To do so, change LL (HH) alarm setpoint prior to changing L (H) alarm setpoint. Similarly, when setting LL (HH) alarm setpoint to a value that exceeds L (H) alarm setpoint, change L (H) alarm setpoint prior to changing LL (HH) alarm setpoint.
- When setting of bargraph zero/span adjustment or digital indicator zero/span adjustment (except decimal point position setting) is saved by **Ⓢ** button, all the alarm setting values (including ones in display-only patterns 1 and 2) are discarded. Digital indicator will show **----** which represents a value lower than 0% for LL/L alarm setpoint (setting 1) and a value exceeding 100% for HH/H alarm setpoint (setting 2). Reconfigure them in such a case.
- In 4-point alarm, to reconfigure alarm setpoints from where the digital indicator is showing **----**, first set L and H alarm setpoints, then LL and HH alarm setpoints.
- To disable alarm output, for LL and L alarm setpoints, keep pressing **Ⓢ** button (for HH and H, **Ⓢ** button) until **----** appears. In 4-point alarm, set LL and HH prior to L and H.
- The user cannot change alarm output logic or set all the alarm outputs to H (or L).

3.2 ALARM TRIP AND BARGRAPH COLOR DISPLAY OPERATION

The figures below show alarm trip action and bargraph color display operation of 2-point alarm and 4-point alarm and display only patterns 1 and 2, respectively.

EXAMPLE OF 2-POINT/4-POINT ALARM

Alarm trips and bargraph color display operation in 4-point alarm

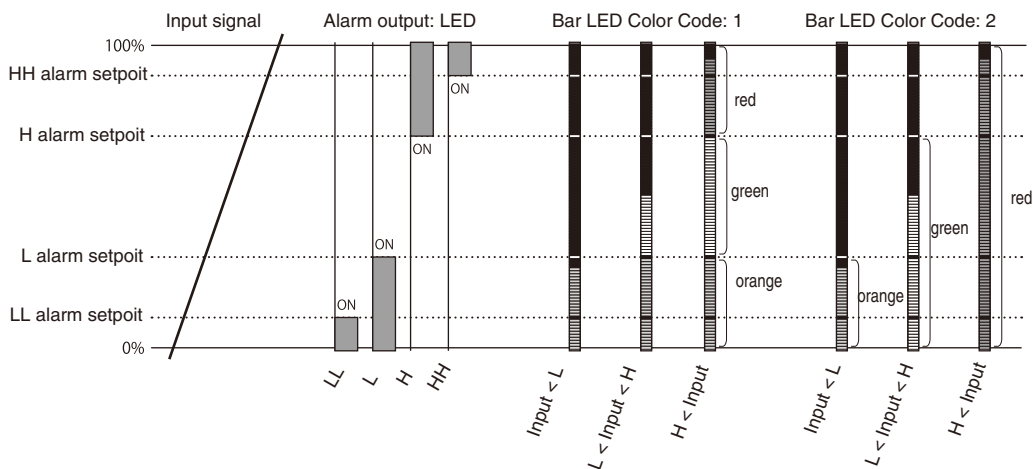

NOTE

- LL and HH alarm setpoints are not available for 2-point alarm.

EXAMPLE OF COLOR DISPLAY OPERATION OF DISPLAY-ONLY PATTERNS 1 AND 2

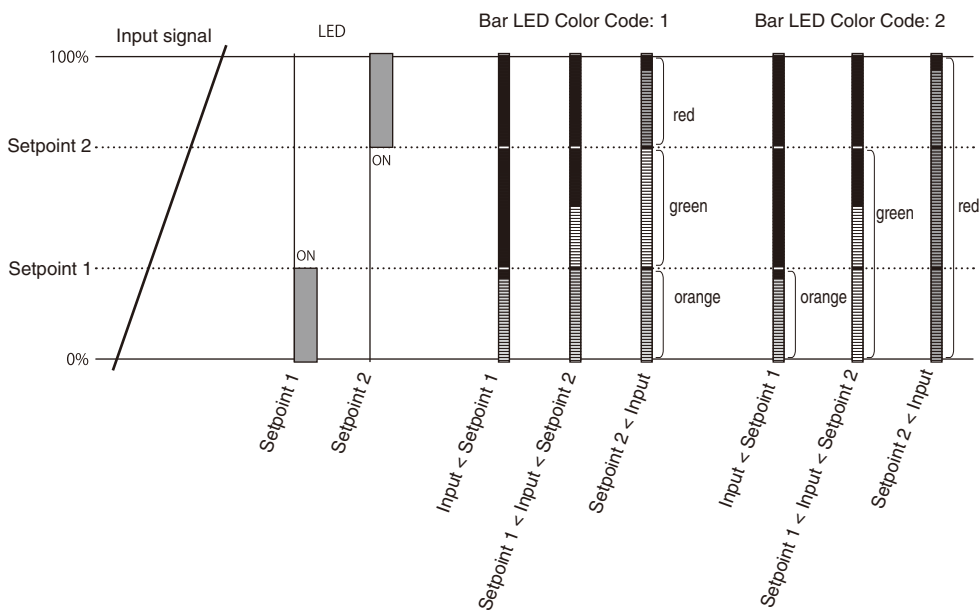

3.3 OPERATING PROCEDURE

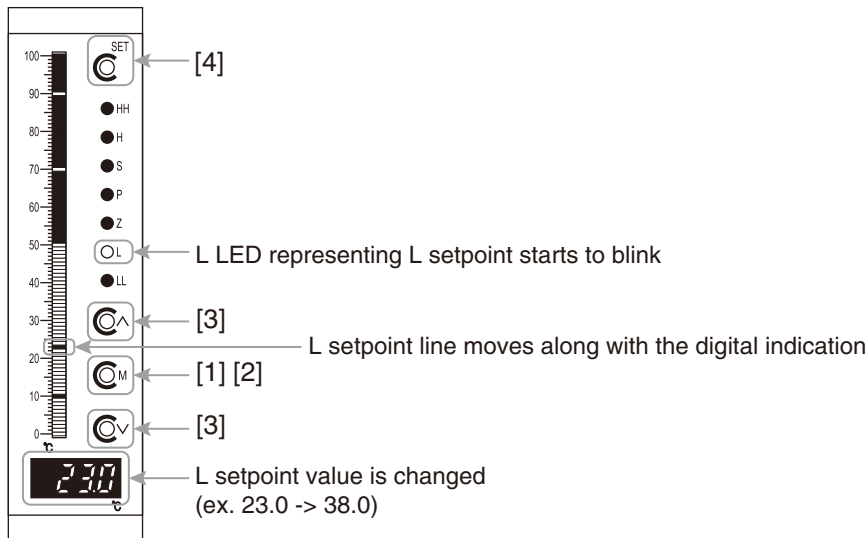

NOTE

- This operating procedure is explained with an example of L alarm setting for 4-point alarm.
- Setting items and which LEDs blink differ depending on Alarm Output Code.
For details, refer to "2.1 BASIC SETTING" on page 22.

[1] Hold down **M** button for over 3 seconds to shift to Setting/Adjustment mode.

- LL alarm setpoint value is displayed on the digital indicator, and LL LED blinks.

[2] Press **M** button to shift to L alarm setpoint.

- L alarm setpoint value is displayed on the digital indicator, and L LED blinks.

[3] Change L alarm setpoint value using **^** or **v** button.

- Set to a value within the range between the currently set LL alarm setpoint and H alarm setpoint.
The L alarm setpoint line on the bargraph moves along.

[4] Press **SET** button to register L alarm setpoint value.

- The value is registered and the unit returns to Measuring mode.

NOTE

- Set other alarm setpoint values in the same manner.
Shift to each item to be changed and perform the same procedure from Steps 2 to 4.
- For the setting range in Step 3, refer to "3.1 SETTING RANGE AND INITIAL SETTING" on page 26.

4. SETTING ALARM ON DELAY TIME

An alarm is tripped when input signal reaches the alarm setpoint (threshold) and if this signal state continues for the specified time duration.

In this manner, an alarm can be prevented from being tripped by a sudden change due to external disturbance, etc.

This time duration is called "ON delay time" and can be set within the range of 0 to 15 seconds.

The initial setting value of "ON delay time" is "0 second."

■ EXAMPLE OF ALARM ON DELAY TIME

- H alarm setpoint

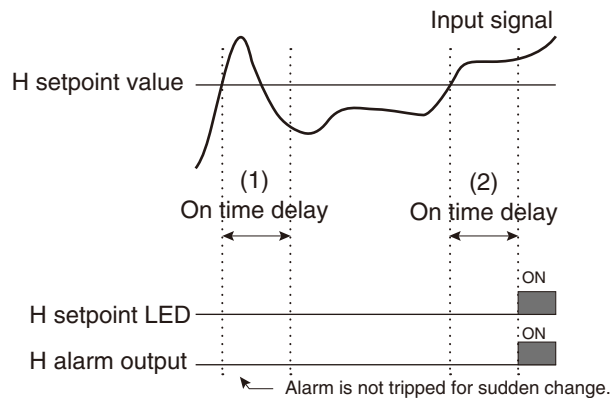

- 1) An alarm is not tripped as input signal has entered the alarm range and left the range before the specified time duration of alarm ON delay time elapses.
H LED is not turned ON either.
- 2) An alarm is tripped as input signal has entered the alarm range and the specified time duration of alarm ON delay time has elapsed.
H LED turns ON simultaneously.

NOTE

- When setting values are adjusted or changed in zero/span adjustment, the alarm ON delay time setting returns to the initial setting value (0.00).
- LL/HH alarm ON delay is not available for 2-point alarm.
- For display-only patterns 1 and 2, ON delay time is configurable, however, DO NOT change from the initial setting (0.00); otherwise, a deviation may occur between timing when the bargraph color display is switched and timing when LED (1) or (2) turns ON.

4.1 OPERATING PROCEDURE

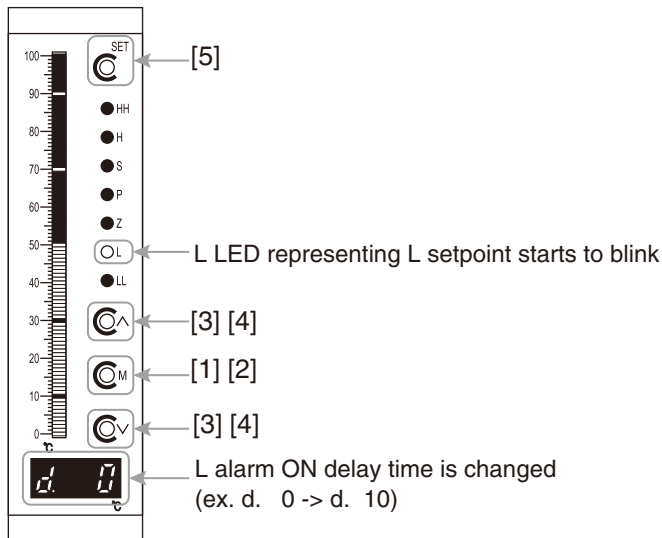

NOTE

- This operating procedure is explained with an example of L alarm setting for 4-point alarm.
- Setting items and which LEDs blink differ depending on Alarm Output Code.
For details, refer to "2.1 BASIC SETTING" on page 22.

[1] Hold down **C_M** button for over 3 seconds to shift to Setting/Adjustment mode.

- LL alarm setpoint value is displayed on the digital indicator, and LL LED blinks.

[2] Press **C_M** button to shift to L alarm setpoint.

- L alarm setpoint value is displayed on the digital indicator, and L LED blinks.

[3] Simultaneously press **C^** and **C^v** buttons to shift to L alarm ON delay time setting.

- L alarm ON delay time is displayed on the digital indicator.

[4] Change L alarm setpoint value using **C^** or **C^v** button.

- Set to a value within the range between d. 0 to d. 15.

[5] Press **C_SET** button to register L alarm ON delay time.

- The value is registered and the unit returns to Measuring mode.

NOTE

- Other alarm ON delay times can be set in the same manner.
Shift to each item to be changed and perform the same procedure from Steps 2 to 5.

5. AVERAGING INPUT

Moving average calculation can be performed on measured values.

The number of samples in processing the moving average calculation can be selected as shown in the following table. This operation averages values of the specified number of samples.

Once the number of samples reaches the specified number, a new sample is added and the oldest one is omitted every time the average calculation is performed.

Such operation is repeated as shown in the following figure.

For instance, when $\overline{R} \ 4$ is selected, the moving average calculation with 4 samples (400 millisecond intervals) is repeated.

Moving averaging helps remove periodic variations in noise superimposed on input signal to thereby suppress the display flickering for better visibility.

■ THE NUMBER OF SAMPLES FOR MOVING AVERAGE

SETTING VALUE	FUNCTION	INITIAL SETTING
$\overline{R} \ 1$	No moving averaging	$\overline{R} \ 4$
$\overline{R} \ 2$	Moving average with 2 samples (200 millisecond intervals)	
$\overline{R} \ 4$	Moving average with 4 samples (400 millisecond intervals)	
$\overline{R} \ 8$	Moving average with 8 samples (800 millisecond intervals)	
$\overline{R} \ 16$	Moving average with 16 samples (1.6 second intervals)	

■ MOVING AVERAGE WITH 4 SAMPLES

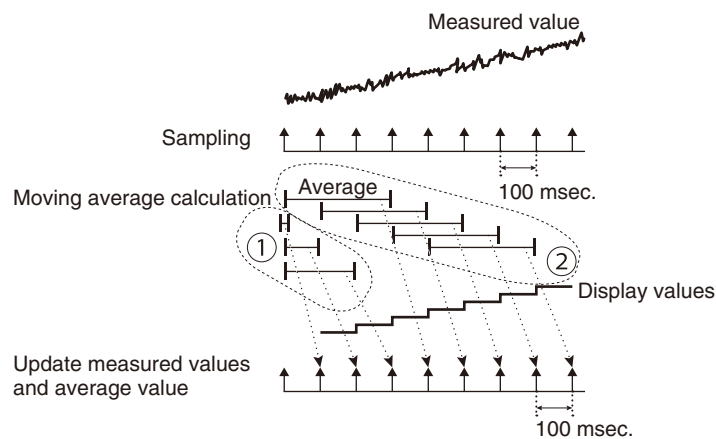

(1) The moving average calculation starts immediately after the power is on or the number of moving average samples is set. Until the number of samples reaches the set value, calculation is performed every 100 milliseconds.

(2) After the number of samples reaches the set value, averaging calculation is performed with a new sample added and the oldest one omitted. Such operation is repeated.

5.1 OPERATING PROCEDURE

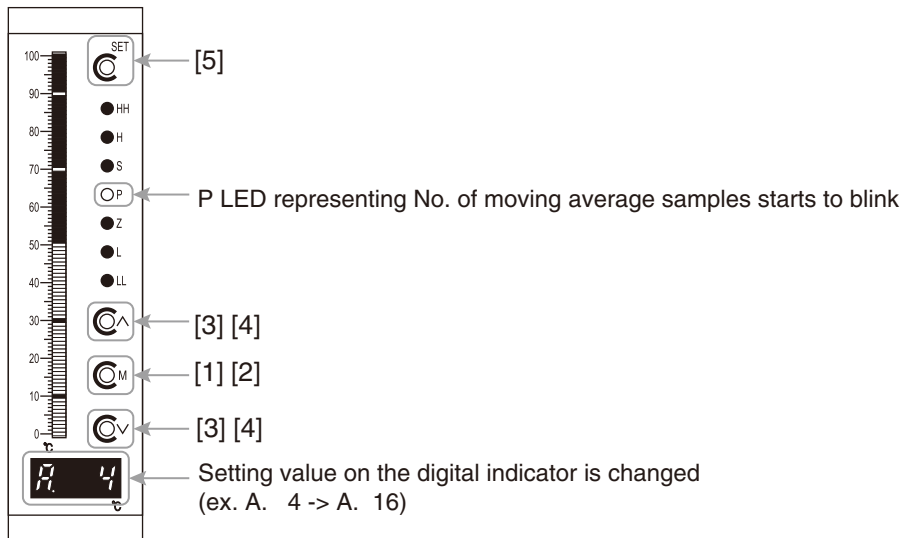

NOTE

- This operating procedure is explained with an example of 4-point alarm.
- Setting items and which LEDs blink differ depending on Alarm Output Code.
For details, refer to "2.1 BASIC SETTING" on page 22.

[1] Hold down **CM** button for over 3 seconds to shift to Setting/Adjustment mode.

- LL alarm setpoint value is displayed on the digital indicator, and LL LED blinks.

[2] Press **CM** button to shift to the decimal point position setting.

- Decimal point position is displayed on the digital indicator, and P (Decimal point) LED blinks.

[3] Simultaneously press **C^** and **Cv** buttons to shift to the moving average setting.

- The number of samples for moving average is displayed on the digital indicator.

[4] Change the number of samples using **C^** or **Cv** button.

- It is selectable from among **A. 1**, **A. 2**, **A. 4**, **A. 8**, and **A. 16**.

[5] Press **SET** button to register the number of samples.

- The value is registered and the unit returns to Measuring mode.

6. ADJUSTING BRIGHTNESS OF DISPLAY

The brightness of the bargraph, digital indication, and LEDs can be adjusted (figures below). The brightness can be selected from the following table.

■ BRIGHTNESS ADJUSTMENT

DISPLAY	FUNCTION	INITIAL SETTING
	Brightness level 1 (dark)	
	Brightness level 2	
	Brightness level 3	
	Brightness level 4	
	Brightness level 5	
	Brightness level 6	
	Brightness level 7 (bright)	

■ ADJUSTMENT IMAGE

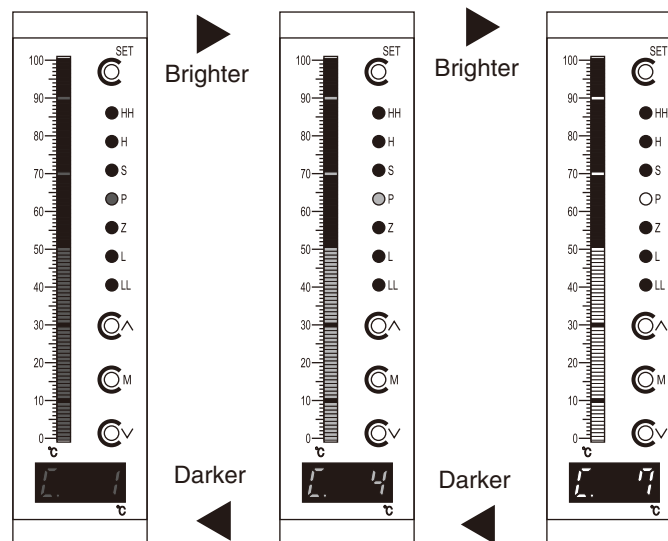

6.1 OPERATING PROCEDURE

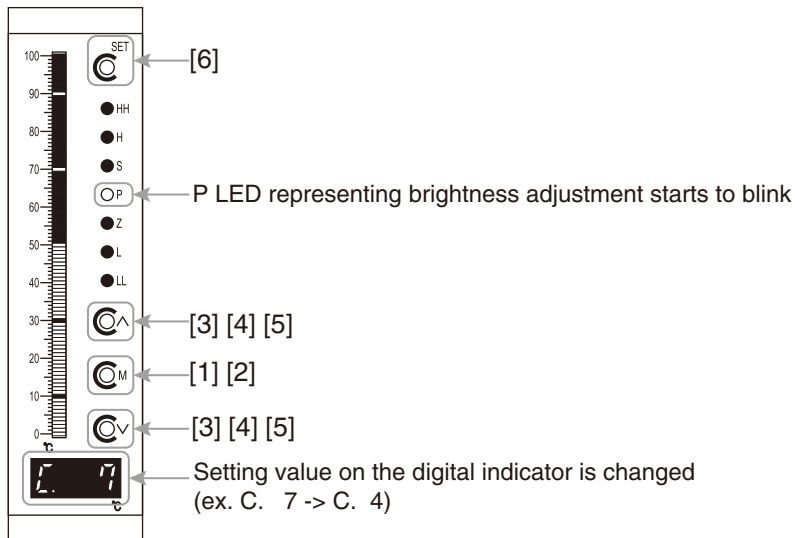

NOTE

- This operating procedure is explained with an example of 4-point alarm.
- Setting items and which LEDs blink differ depending on Alarm Output Code.
For details, refer to "2.1 BASIC SETTING" on page 22.

[1] Hold down **CM** button for over 3 seconds to shift to Setting/Adjustment mode.

- LL alarm setpoint value is displayed on the digital indicator, and LL LED blinks.

[2] Press **CM** button to shift to the decimal point position setting.

- Decimal point position is displayed on the digital indicator, and P (Decimal point) LED blinks.

[3] Simultaneously press **C^** and **Cv** buttons to shift to the moving average setting.

- The number of samples for moving average is displayed on the digital indicator.

[4] Simultaneously press **C^** and **Cv** buttons again to shift to the brightness adjustment.

- The currently set brightness is displayed on the digital indicator.

[5] Change the brightness using **C^** or **Cv** button.

- Select one among to .

[6] Press **CSET** button to register the adjusted brightness.

- The value is registered and the unit returns to Measuring mode.

7. SETTING DIGITAL INDICATOR

7.1 DIGITAL INDICATOR SETTING

Input signal can be displayed as an arbitrary value ranging from -1999 to 9999 on the digital indicator. In the digital indicator setting, there are 2 types, i.e. zero adjustment and span adjustment, and the decimal point can be set at an arbitrary position.

- Digital indicator zero adjustment for a display value of input signal 0%
- Digital indicator span adjustment for a display value of input signal 100%
- Decimal point position is common for zero and span adjustments.

e.g. Digital indication 0.0 to 100.0°C

Digital indicator zero adjustment : 0.0°C

Digital indicator span adjustment: 100.0°C

Decimal point position: 100.0 (one decimal place)

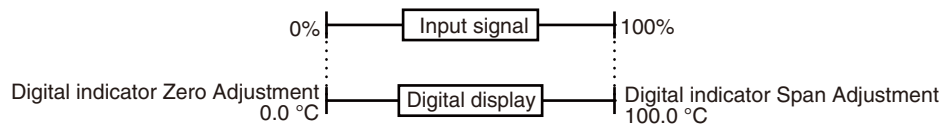

IMPORTANT

- Digital indicator is factory-set to the values specified at ordering time, thus, normally should be left as it is.
- When digital indicator zero/span adjustment (except the decimal point position setting) is saved by **SET** button, all the alarm setting values (including ones in display-only patterns 1 and 2) are discarded, and the alarm ON delay setting returns to the initial setting value (0.0).
- We recommend to record the alarm setting values (display setting values of bargraph colors) and alarm ON delay setting values as necessary.
- When “Reset to Factory Setting” is executed, digital indicator zero and span adjustments are reset to the factory-set values (values specified at ordering time). Note that the decimal point position will not be reset.
- Set values such that “digital indicator zero adjustment < digital indicator span adjustment”.
- The minimum settable span is “100” (3 digits ignoring the decimal point position).

7.2 SETTING PROCEDURES OF DIGITAL INDICATOR

The setting procedures are explained in the order of “Digital indicator Zero Adjustment”, “Digital indicator Span Adjustment”, and “Decimal Point Position”, however, the actual settings can be performed in any order.

NOTE

- Digital indicator zero/span adjustment can also be performed along with bargraph zero/span adjustment.

7.3 OPERATING PROCEDURE FOR SETTING DIGITAL INDICATOR ZERO ADJUSTMENT

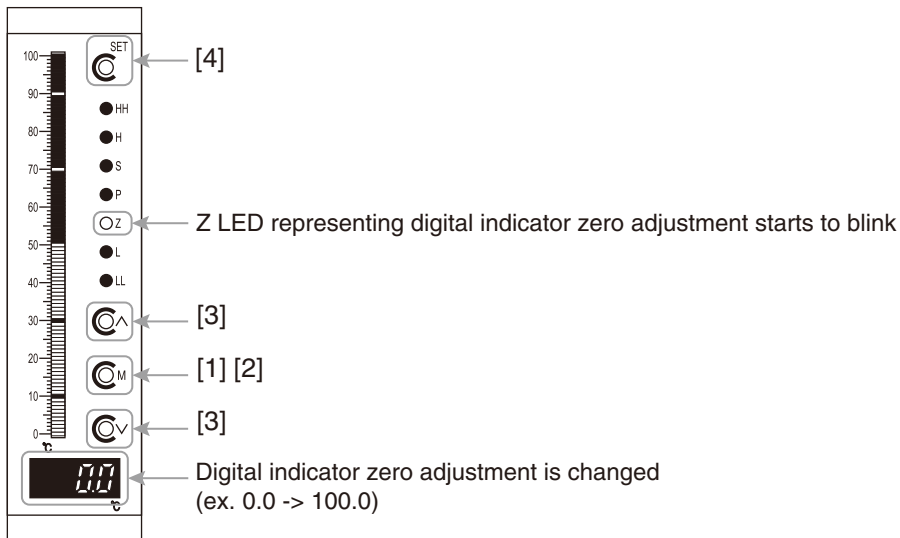

NOTE

- This operating procedure is explained with an example of 4-point alarm.
- Setting items and which LEDs blink differ depending on Alarm Output Code. For details, refer to "2.1 BASIC SETTING" on page 22.
- Decimal point varies according to the decimal point position setting. Set values in display digits ignoring decimal point.

.....

[1] Hold down M button for over 3 seconds to shift to Setting/Adjustment mode.

- LL alarm setpoint value is displayed on the digital indicator, and LL LED blinks.

.....

[2] Press M button to shift to the digital indicator zero adjustment.

- Digital indicator zero adjustment is displayed on the digital indicator, and Z (zero) LED blinks.

.....

[3] Change the digital indicator zero adjustment using ^ or v button.

- It can be set within the range between 9999 and 9999 .

.....

[4] Press SET button to register the digital indicator zero adjustment.

- The value is registered and the unit returns to Measuring mode.

7.4 OPERATING PROCEDURE FOR SETTING DIGITAL INDICATOR SPAN ADJUSTMENT

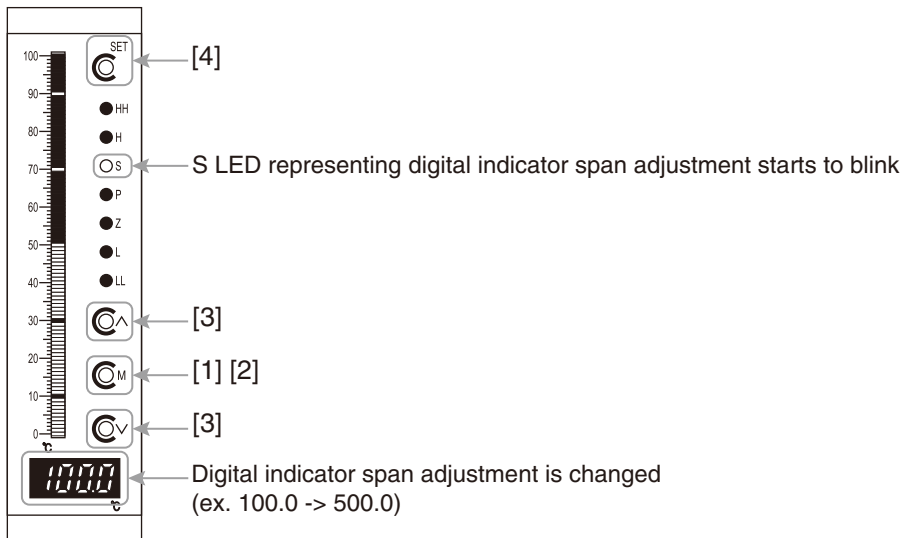

NOTE

- This operating procedure is explained with an example of 4-point alarm.
- Setting items and which LEDs blink differ depending on Alarm Output Code. For details, refer to "2.1 BASIC SETTING" on page 22.
- Decimal point varies according to the decimal point position setting. Set values in display digits ignoring decimal point.

[1] Hold down **C_M** button for over 3 seconds to shift to Setting/Adjustment mode.

- LL alarm setpoint value is displayed on the digital indicator, and LL LED blinks.

[2] Press **C_M** button to shift to the digital indicator span adjustment.

- Digital indicator span adjustment is displayed on the digital indicator, and S (span) LED blinks.

[3] Change the digital indicator span adjustment using **C^** or **C^v** button.

- It can be set within the range between **1999** and **9999**.

[4] Press **C_SET** button to register the digital indicator span adjustment.

- The value is registered and the unit returns to Measuring mode.

7.5 OPERATING PROCEDURE FOR SETTING DECIMAL POINT POSITION

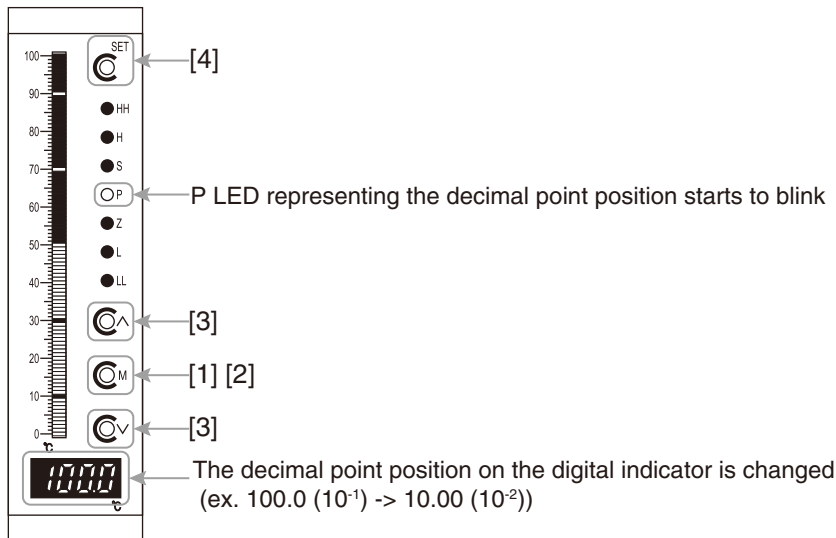

NOTE

- This operating procedure is explained with an example of 4-point alarm.
- Setting items and which LEDs blink differ depending on Alarm Output Code. For details, refer to "2.1 BASIC SETTING" on page 22.
- Digital indicator shows the value set in the digital indicator span adjustment.

[1] Hold down **ⓄM** button for over 3 seconds to shift to Setting/Adjustment mode.

- LL alarm setpoint value is displayed on the digital indicator, and LL LED blinks.

[2] Press **ⓄM** button to shift to the decimal point position setting.

- Decimal point position is displayed on the digital indicator, and P (Decimal point) LED blinks.

[3] Change the decimal point position using **Ⓞ^** or **Ⓞv** button.

- Set to a value referring to the table below.

SETTING VALUE	FUNCTION
ⓄⓄⓄⓄ	No decimal point
ⓄⓄⓄⓄ	1 digit after the decimal point (10 ⁻¹)
ⓄⓄⓄⓄ	2 digits after the decimal point (10 ⁻²)
ⓄⓄⓄⓄ	3 digits after the decimal point (10 ⁻³)

[4] Press **ⓄSET** button to register the decimal point position.

- The value is registered and the unit returns to Measuring mode.

8. USER CALIBRATION

User calibration is performed by a customer in order to calibrate input signal using customer's measuring instruments and standards and to adjust deviations from field devices.

To calibrate input signal, use "Bargraph Zero/Span Adjustment" function.

The unit is calibrated correctly before shipment and normally does not require user calibration.

■ BARGRAPH ZERO/SPAN ADJUSTMENT

When calibration/adjustment is necessary, do so using Bargraph Zero/Span Adjustment function.

The adjustment can be performed by applying actual input signals.

Please note that we do not guarantee the result of your own calibration/adjustment.

The internal calibration data is overwritten every time the unit is calibrated, and the data is kept stored even after the power is turned off.

Note that when "Reset to Factory Setting" is executed, the calibration data is discarded and values are reset to the factory-set values.

Measuring instruments and equipment for calibration shall be prepared by the user.

Refer to the respective manuals carefully on how to handle the instruments and equipment.

■ REGULAR CALIBRATION

Perform calibration regularly in manner of the procedure below.

Warm up the unit for at least 10 minutes and then apply 0%, 25%, 50%, 75%, 100% input signal in this order.

Check that the bargraph and digital indicator each show 0%, 25%, 50%, 75%, 100% and remain within the specified accuracy range.

When their values are out of the range, calibrate the unit according to each method of adjustment described above.

8.1 BARGRAPH ZERO/SPAN ADJUSTMENT

■ FLOW OF BARGRAPH ZERO/SPAN ADJUSTMENT

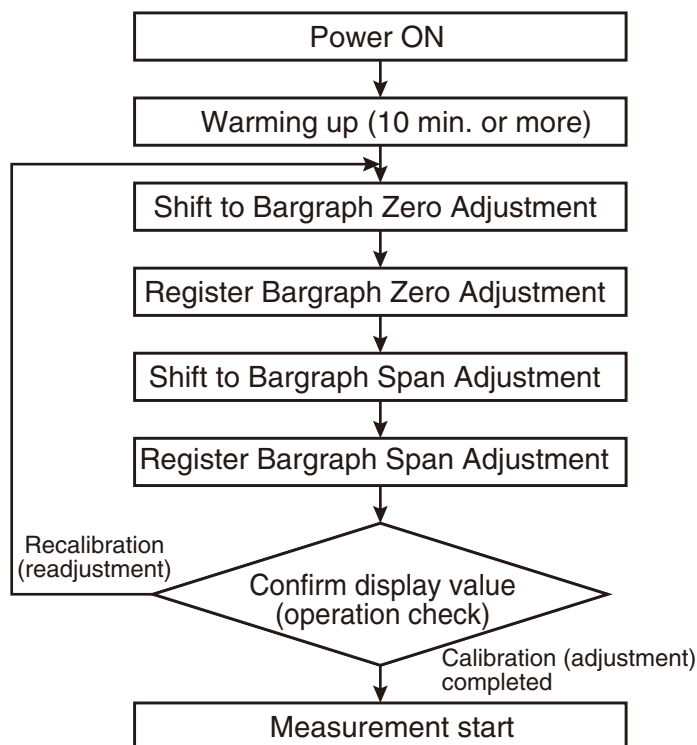

IMPORTANT

- When the bargraph zero/span adjustment is saved by **SET** button, all the alarm setting values (including ones in the display-only patterns 1 and 2) are discarded, and the alarm ON delay setting returns to the initial setting value (2.0). We recommend to record alarm setpoint values (display setting values of bargraph colors) and alarm ON delay setting values as necessary.
- For stable operation of 48NDT, warm up measuring instruments, equipment, and other field devices used for calibration (adjustment) for more than the time specified in the respective manuals.
- Adjustable ranges are as follows:
 - Zero adjustment.....0 to 10%
 - Span adjustment.....90 to 100%
- In the following operating procedure, input signal is applied in Step 1, however, input signal can be applied at any timing before pressing **SET** button in Step 4.

8.2 OPERATING PROCEDURE OF BARGRAPH ZERO ADJUSTMENT

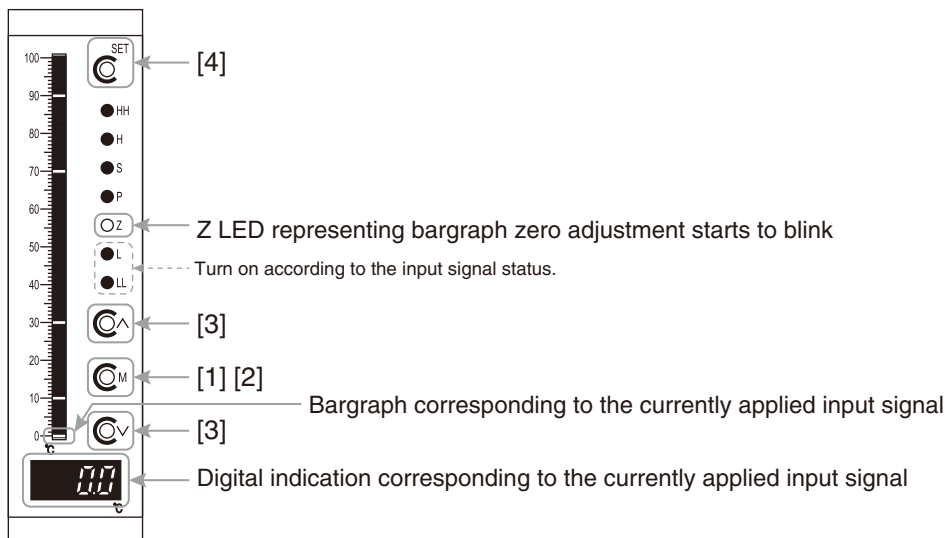

NOTE

- This operating procedure is explained with an example of 4-point alarm.
- Setting items and which LEDs blink differ depending on Alarm Output Code. For details, refer to "2.1 BASIC SETTING" on page 22.

[1] With applying 0% input signal, hold down **M** button for over 3 seconds to shift to Setting/Adjustment mode.

- LL alarm setpoint value is displayed on the digital indicator, and LL LED blinks.

[2] Press **M** button to shift to the digital indicator zero adjustment.

- Digital indicator zero adjustment is displayed on the digital indicator, and Z (zero) LED blinks.

[3] Simultaneously press **^** and **v** buttons to shift to the bargraph zero adjustment.

- Z (zero) LED that was blinking turns on.

[4] Confirm that the input signal is stable before pressing **SET** button to register the bargraph zero adjustment.

- The deviation between the bargraph 0% and the digital indicator 0% is compensated and the unit returns to Measuring mode.

NOTE

- The digital indication can also be changed by performing digital indicator zero adjustment along with the bargraph zero adjustment. Before pressing **SET** button in step [4], operate **^** and **v** buttons to change the digital indicator zero adjustment and press **SET** button to register both of the bargraph and digital indicator zero adjustments. Refer to steps [3] and [4] in "7.3 OPERATING PROCEDURE FOR SETTING DIGITAL INDICATOR ZERO ADJUSTMENT" on page 36.

8.3 OPERATING PROCEDURE OF BARGRAPH SPAN ADJUSTMENT

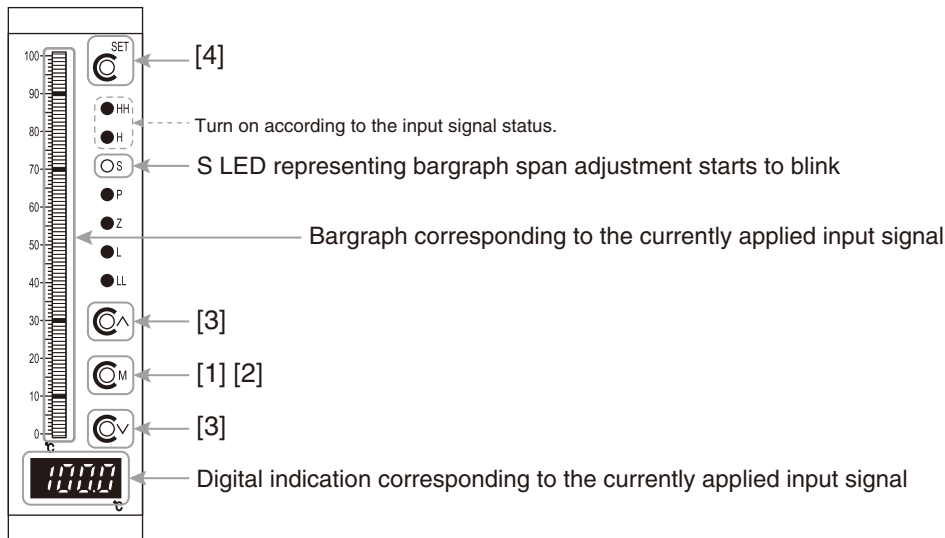

NOTE

- This operating procedure is explained with an example of 4-point alarm.
- Setting items and which LEDs blink differ depending on Alarm Output Code. For details, refer to "2.1 BASIC SETTING" on page 22.
- When the bargraph span adjustment is performed after the bargraph zero adjustment in succession, start from Step 2 if within 1 minute after the last button operation.

[1] With applying 100% input signal, hold down **(M)** button for over 3 seconds to shift to Setting/Adjustment mode.

- LL alarm setpoint value is displayed on the digital indicator, and LL LED blinks.

[2] Press **(M)** button to shift to the digital indicator span adjustment.

- Digital indicator span adjustment is displayed on the digital indicator, and S (span) LED blinks.

[3] Simultaneously press **(^)** and **(v)** buttons to shift to the bargraph span adjustment.

- S (span) LED that was blinking turns on.

[4] Confirm that the input signal is stable before pressing **(SET)** button to register the bargraph span adjustment.

- The deviation between the bargraph 100% and the digital indicator 100% is compensated and the unit returns to Measuring mode.

NOTE

- The digital indication can also be changed by performing digital indicator span adjustment along with the bargraph span adjustment. Before pressing **(SET)** button in step [4], operate **(^)** and **(v)** buttons to change the digital indicator span adjustment and press **(SET)** button to register both of the bargraph and digital indicator span adjustments. Refer to steps [3] and [4] in "7.4 OPERATING PROCEDURE FOR SETTING DIGITAL INDICATOR SPAN ADJUSTMENT" on page 37.

8.4 RESETTING CALIBRATION DATA TO FACTORY-SET VALUES

Execute “Reset to Factory Setting” to reset calibration data of the bargraph zero and span adjustments to the factory-set values.

The digital display zero and span adjustments are reset to the factory-set values as well, however, the decimal point position will not be reset and remains at the currently set position.

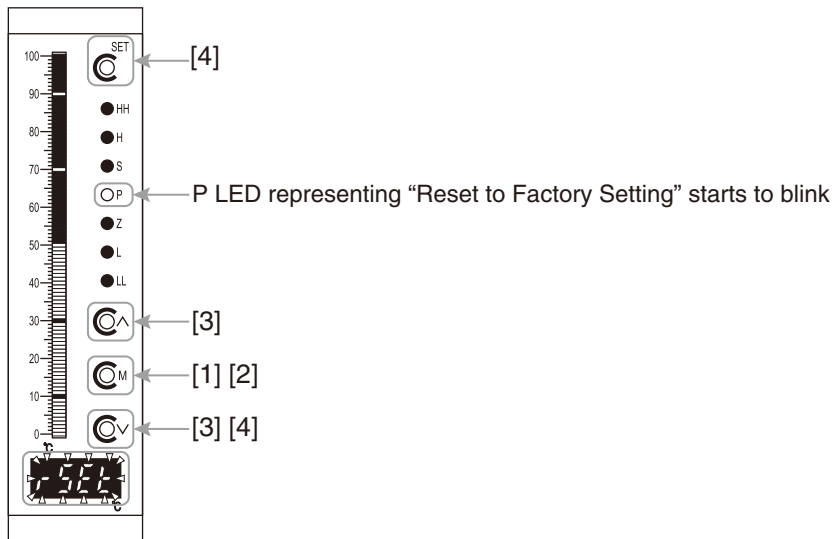

NOTE

- This operating procedure is explained with an example of 4-point alarm.
- Setting items and which LEDs blink differ depending on Alarm Output Code.
For details, refer to "2.1 BASIC SETTING" on page 22.

[1] Hold down **CM** button for over 3 seconds to shift to Setting/Adjustment mode.

- LL alarm setpoint value is displayed on the digital indicator, and LL LED blinks.

[2] Press **CM** button to shift to the decimal point position setting.

- Decimal point position is displayed on the digital indicator, and P (Decimal point) LED blinks.

[3] Simultaneously press **^** and **v** buttons 3 times to shift to “Reset to Factory Setting.”

- **555** will be displayed while blinking.

[4] Simultaneously press **SET** and **v** buttons to execute “Reset to Factory Setting.”

- “Reset to Factory Setting” is executed and the unit returns to Measuring mode.

9. REPLACEMENT OF SCALE PLATE

The scale plate can be easily replaced by customers.
Contact us or local representative for ordering a new scale plate.
Follow the procedure below for detaching and attaching the scale plate.

9.1 DETACHING SCALE PLATE

- 1) Lift the slider up in the direction shown by the arrow.
- 2) Hold the upper end part of the scale plate and pull forward to remove from the unit.

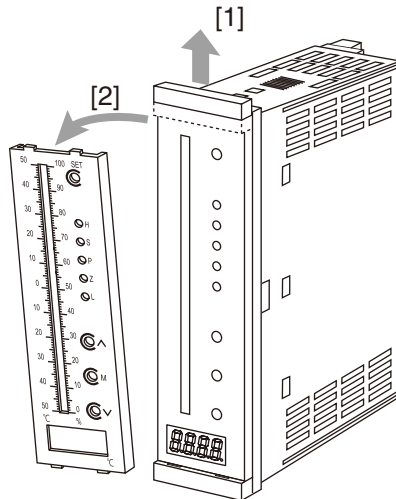

9.2 ATTACHING SCALE PLATE

- 1) Fit the convex portions at the bottom end of the scale plate into the concave portions of the unit.
- 2) Press the scale plate against the unit.
- 3) Pull down the slider until it clicks into place.

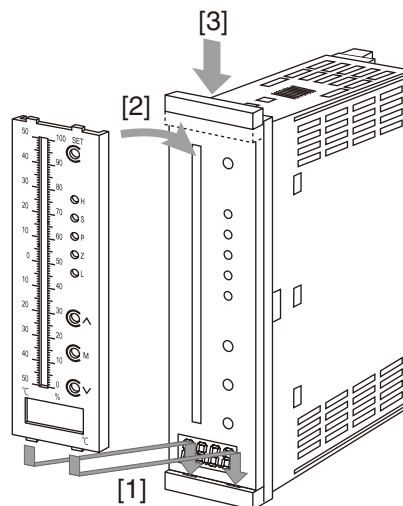

10. INSPECTION AND CLEANING

To use the unit in the normal and best conditions, inspect and clean the unit routinely or periodically.

- When the display and the buttons are soiled, wipe off with a wet soft cloth.
Do not use organic solvent such as benzine, thinner, or alcohol.
Doing so may result in deformation or discoloration of the unit.
- Make sure that there is no abnormality such as smoke, unusual odor, or abnormal noise coming from the unit.
Continued use of the unit under such abnormal conditions may result in a fire or electric shock.
- Periodically check to ensure that the terminal screws are not loose.
When checking, interrupt electricity to the power supply, input, and alarm output for safety.
- Periodically check to ensure that the terminal block screws are not loose.
When checking, interrupt electricity to the power, input, and alarm output for safety.
- Periodically check that the mounting brackets are fixed tightly.
Loose brackets may cause drop of the unit.

11. APPENDICES

11.1 SPECIFICATIONS

■ GENERAL SPECIFICATIONS

Construction	Panel mount type	
Degree of protection	IP65: the level of protection applicable to the front panel of the unit which is singly mounted according to the specified method.	
Connection	M3 separable screw terminal (torque 0.6 N-m)	
Screw terminal	Nickel-plated steel	
Housing material	Flame-resistant resin (black)	
Isolation	Input to output to power	
Burnout	Upscale standard; Downscale or no burnout optional	
Linearization	Equipped as standard	
Cold junction compensation	CJC sensor attached to the input terminals (No CJC for B thermocouple)	
Display zero adjustment	0 to 10%	
Display span adjustment	90 to 100%	
Scale plate	Flame resistant resin (white scale & characters on black base)	
H & L alarm output delay	Selectable between 0 and 15 sec. by 1 sec. increments (initial setting: 0 sec.)	
Setpoint adjustment	2 points H : [L setpoint] to 100% L : 0 to [H setpoint] or No alarm trip 4 points HH: [H setpoint] to 100% H : [L setpoint] to [HH setpoint] L : [LL setpoint] to [H setpoint] LL: 0 to [L setpoint] or No alarm trip	
Alarm deadband (hysteresis)	1%	
Setting items (Front button)	Setting/Adjustment Mode	HH, H, L, and LL alarm setpoints, (setpoints 1 and 2); HH, H, L, and LL ON delay time; Digital indicator zero/span adjustment; Bargraph zero/span adjustment; Decimal point position; No. of moving average samples; Brightness adjustment; Reset to Factory Setting
Read rate	100 msec. (10 samples /sec.)	
Moving average sample number	Selectable among 1, 2, 4, 8, and 16 (initial setting: 4)	
LED brightness adjustment	7 levels (initial setting: 7 (bright))	

■ BARGRAPH

LED	101-segment LED, 100 mm (3.96") long, 3.00 mm (.12") wide	
Display range	0 to 100 (scaling function not available) (the bar blinks at 0% or 100% position when over range)	
Burnout	Upscale	The 100 % position segment blinks.
	Downscale	The 0 % position segment blinks.
Scale	Two different scales available for single bargraph	
Characters	Max. 4 characters including decimal point and negative sign	
Divisions	Min. 22, max. 100	
Engineering unit	Max. 6 characters	

■ DIGITAL DISPLAY

Indicator	7-segment red LED with 8 mm (.31") character height	
Number of digits	4 digits	
Setting range	-1999 to 9999 (Min. 3 significant digits)	
Minimum scale value	100 (3 digits with the decimal point ignored)	
Scaled range	The range between -1999 to 9999 and -15 to +115% of input span (The indicator blinks when the input is out of the range)	
Burnout	Upscale	A value equivalent to 115 % is displayed while blinking.
	Downscale	A value equivalent to -15 % is displayed while blinking.
Decimal point position	10 ⁻¹ , 10 ⁻² , 10 ⁻³ , or none	
Zero indication	Leading zeros suppression	
Engineering unit	Max. 6 characters printed on the scale plate	

■ INPUT SPECIFICATIONS

Input resistance	≥ 20k Ω	
Burnout sensing current	≤ 0.25 μA	
Manufacturing range		
Span	≥ 3 mV	
Usable range	(PR)	0 to 1760°C, 32 to 3200°F
	K (CA)	-270 to +1370°C, -454 to +2498°F
	E (CRC)	-270 to +1000°C, -454 to +1832°F
	J (IC)	-210 to +1200°C, -346 to +2192°F
	T (CC)	-270 to +400°C, -454 to +752°F
	B (RH)	0 to 1820°C, 32 to 3308°F
	R	-50 to +1760°C, -58 to +3200°F
	S	-50 to +1760°C, -58 to +3200°F
	N	-270 to +1300°C, -454 to +2372°F
Minimum span (approx.)	(PR)	370°C, 670°F
	K (CA)	75°C, 140°F
	E (CRC)	50°C, 90°F
	J (IC)	60°C, 110°F
	T (CC)	75°C, 140°F
	B (RH)	780°C, 1450°F
	R	360°C, 680°F
	S	380°C, 700°F
	N	110°C, 200°F
Lower range	(PR)	0 to 880°C, 32 to 1616°F
	K (CA)	-270 to +1200°C, -454 to +2192°F
	E (CRC)	-270 to +750°C, -454 to +1382°F
	J (IC)	-210 to +800°C, -346 to +1472°F
	T (CC)	-270 to +325°C, -454 to +617°F
	B (RH)	0 to 750°C, 32 to 1382°F
	R	-50 to +550°C, -58 to +1022°F
	S	-50 to +550°C, -58 to +1022°F
	N	-270 to +1100°C, -454 to +2012°F

* The transmitter may not satisfy specified accuracy for temperature ranges below 0°C.

■ OUTPUT SPECIFICATIONS

Alarm output	Relay contact Rated load: 250 V AC @ 1 A (cos φ = 1) 30 V DC @ 5 A (resistive load) Maximum switching voltage: 250 V AC, 220 V DC Maximum switching power: 380 VA, 150 W (resistive load) Minimum load: 5 V DC @ 100 mA Mechanical life: ≥ 5 × 10 ⁶ cycles (rate 180 cycles/min.)
--------------	--

■ INSTALLATION

Power consumption	AC power	M: 85 – 264 V AC	Operational voltage range 85 – 264 V AC, 50/60 Hz Approx. 5.5 VA at 100 V with max. load Approx. 7 VA at 200 V with max. load Approx. 8 VA at 264 V with max. load
		M2: 100 – 240 V AC	Operational voltage range 85 – 264 V AC, 50/60 Hz Approx. 5.5 VA at 100 V with max. load Approx. 7 VA at 200 V with max. load Approx. 8 VA at 264 V with max. load
	DC power	R: 24 V DC	Operational voltage range 24 V DC \pm 15% Ripple 10% p-p max. Approx. 3.5 W at 20.4 V with max. load Approx. 3.5 W at 24 V with max. load Approx. 3.5 W at 27.6 V with max. load
Operating temperature		-5 to +55°C (23 to 131°F)	
Operating humidity		30 to 90% RH (non-condensing)	
Altitude		up to 2000 meters	
Mounting		Panel flush mounting	
Weight		300 g (0.66 lb)	

■ PERFORMANCE (IN PERCENTAGE OF SPAN)

Accuracy	Bargraph	$\pm 1\% \pm 1$ digit (at over 400°C or 750°F for R, S, and PR; over 770°C or 1420°F for B)
	Digital indicator	Digital indicator: $\pm 0.5\% \pm 1$ digit (at over 400°C or 750°F for R, S and, PR; over 770°C or 1420°F for B)
Cold junction compensation error		(at 20°C \pm 10°C or 68°F \pm 18°F) K, E, J, T, N: $\pm 0.5^\circ\text{C}$ or $\pm 0.9^\circ\text{F}$ S, R, PR: $\pm 1^\circ\text{C}$ or $\pm 1.8^\circ\text{F}$
Temperature coefficient		$\pm 0.015\%$ of FS/ $^\circ\text{C}$ ($\pm 0.008\%$ of FS/ $^\circ\text{F}$) (at over 400°C or 750°F for R, S and PR; over 770°C or 1420°F for B)
Response time		≤ 0.5 sec. (The number of moving average samples: 4)
Burnout response		≤ 10 sec.
Insulation resistance		Input to output to power $\geq 100\text{ M}\Omega$ with 500 V DC
Dielectric strength		Input to output to power to ground 2000 V AC @ 1 minute

■ STANDARDS & APPROVALS

EU conformity	EMC Directive EMI EN 61000-6-4 EMS EN 61000-6-2 Low Voltage Directive EN 61010-1 Measurement Category II (output) Installation Category II (power) Pollution degree 2 Input to output to power: Reinforced insulation (300 V) RoHS Directive
UK conformity	The UK legislations and designated standards are equivalent to the applicable EU directives. (Refer to our web site for more information about the legislations and designated standards.)

11.2 MODEL NUMBERING

Code number: **48NDT**–[1][2][3]–[4][5]

[1] ALARM OUTPUT

- 0: None
- 2: 2 points
- 4: 4 points

[2] BAR LED COLOR

- R: Red
- Y: Amber
- G: Green
- B: Blue
- 1: Multi-color (red, orange, and green), Pattern 1
- 2: Multi-color (red, orange, and green), Pattern 2

[3] INPUT

- 1: (PR) (Usable Range 0 to 1760°C, 32 to 3200°F)
- 2: K (CA) (Usable range -270 to +1370°C; -454 to +2498°F)
- 3: E (CRC) (Usable range -270 to +1000°C; -454 to +1832°F)
- 4: J (IC) (Usable range -210 to +1200°C; -346 to +2192°F)
- 5: T (CC) (Usable range -270 to +400°C; -454 to +752°F)
- 6: B (RH) (Usable range 0 to 1820°C; 32 to 3308°F)
- 7: R (Usable range -50 to +1760°C; -58 to +3200°F)
- 8: S (Usable range -50 to +1760°C; -58 to +3200°F)
- N: N (Usable range -270 to +1300°C; -454 to +2372°F)

[4] POWER INPUT

AC Power

M: 85 – 264 V AC (Operational voltage range 85 – 264 V, 50/60 Hz (CE marking not available))

M2: 100 – 240 V AC (Operational voltage range 85 – 264 V, 50/60 Hz)

DC Power

R: 24 V DC (Operational voltage range 24 V ±15 %, ripple 10% p-p max.)

[5] OPTIONS

Standards & Approvals

Blank: Without CE

/CE: CE marking

Bezels

Blank: Bezels for the 48 Series panel cutout

/D: Bezels for DIN panel cutout

/F: Bezels for Fuji Electric's PAJ, PAK, PBA panel cutout

Burnout

blank: Upscale burnout

/BL: Downscale burnout

/BN: No burnout

Other Options

Blank: none

/Q: Option other than the above (specify the specification)

■ SPECIFICATIONS OF OPTION: Q

COATING (For the detail, refer to our web site.)

Moving parts and indicators are not coated.

/C01: Silicone coating

/C02: Polyurethane coating

/C03: Rubber coating

EX-FACTORY SETTING

/SET: Preset according to the Ordering Information Sheet (No. ESU-9436)

11.3 PARAMETER LIST

■ 2-POINT ALARM TRIP / 4-POINT ALARM TRIP

MODE	PARAMETER	SETTING RANGE	LED	DISPLAY	INITIAL SETTING	DECIMAL POINT	UNIT
Measuring	Present value	-1999 – 9999			----	As per the set position	User-defined
Setting/ Adjustment	LL setpoint	-1999 – 9999	LL blinking	1999 to 9999	10%	As per the set position	User-defined
	LL ON delay time	0 – 15	LL blinking	0 to 15	0	----	Second
	L setpoint	-1999 – 9999	L blinking	1999 to 9999	30%	As per the set position	User-defined
	L ON delay time	0 – 15	L blinking	0 to 15	0	----	Second
	Digital indicator zero adj.	-1999 – 9999	Z blinking	1999 to 9999	As per the Ordering Information Sheet	As per the set position	User-defined
	Bargraph zero adj.	-10 – +10%	Z ON	----	----	----	----
	Decimal point position	No decimal point, 10 ⁻¹ , 10 ⁻² , 10 ⁻³	P blinking	0000 , 0000 , 0000 , 0000	As per the Ordering Information Sheet	----	----
	No. of moving average samples	None, 2, 4, 8, 16	P blinking	0 , 2 , 4 , 8 , 16	4	----	Sample(s)
	Brightness adj.	1 (dark) to 7 (bright)	P blinking	0 to 7	7	----	----
	Reset to Factory Setting	RESET	P blinking	1555 blinking	----	----	----
	Digital indicator span adj.	-1999 – 9999	S blinking	1999 to 9999	As per the Ordering Information Sheet	As per the set position	User-defined
	Bargraph span adj.	90 – 110%	S ON	----	----	----	----
	H setpoint	-1999 – 9999	H blinking	1999 to 9999	70%	As per the set position	User-defined
	H ON delay time	0 – 15	H blinking	0 to 15	0	----	Second
HH setpoint	-1999 – 9999	HH blinking	1999 to 9999	90%	As per the set position	User-defined	
HH ON delay time	0 – 15	HH blinking	0 to 15	0	----	Second	

* HH and LL related settings are not available for 2 points alarm models.

■ DISPLAY ONLY

MODE	PARAMETER	SETTING RANGE	LED	DISPLAY	INITIAL SETTING	DECIMAL POINT	UNIT
Measuring	Current value	-1999 – 9999		----	----	As per the set position	User-defined
Setting / Adjustment	Setpoint 1 value	-1999 – 9999	1 blinking		30%	As per the set position	User-defined
	Digital indicator zero adj.	-1999 – 9999	Z blinking		As per the Ordering Information Sheet	As per the set position	User-defined
	Bargraph zero adj.	-10 – +10%	Z ON	----	----	----	----
	Decimal point position	No decimal point, 10 ⁻¹ , 10 ⁻² , 10 ⁻³	P blinking		As per the Ordering Information Sheet	----	----
	No. of moving average samples	None, 2, 4, 8, 16	P blinking			----	Sample(s)
	Brightness adj.	1 (dark) to 7 (bright)	P blinking			----	----
	Reset to Factory Setting	RESET	P blinking		----	----	----
	Digital indicator span adj.	-1999 – 9999	S blinking		As per the Ordering Information Sheet	As per the set position	User-defined
	Bargraph span adj.	90 – 110%	S ON	----	----	----	----
	Setpoint 2 value	-1999 – 9999	2 blinking		70%	As per the set position	User-defined

* Setpoint 1 and Setpoint 2 related settings are available only for Display only patterns 1 and 2 models.