

RTD INPUT DIGITAL PANEL METER
 (4 digit, LED display type, with terminal block)

MODEL **47NLRT**

BEFORE USE

Thank you for choosing us. Before use, please check contents of the package you received as outlined below. If you have any problems or questions with the product, please contact our sales office or representatives.

■ PACKAGE INCLUDES:

- Digital panel meter(1)
- Terminal block.....(1)
- Engineering unit sticker label sheet.....(1)
- Unit fixing screw (M4 × 10)(2)
- Unit fixing screw (M4 × 20)(2)
- Watertight packing(1)
- Insulation Sheet.....(1)

■ MODEL NO.

Confirm Model No. marking on the product to be exactly what you ordered.

■ INSTRUCTION MANUAL

This manual describes necessary points of caution when you use this product, including installation, connection and basic maintenance procedures.

For detailed explanations to operate and program the module, please refer to Model 47NLRT Operating Manual (EM-9566-B), downloadable at our web site.

POINTS OF CAUTION

■ CONFORMITY WITH EU DIRECTIVES

- The equipment must be installed such that appropriate clearance and creepage distances are maintained to conform to CE requirements. Failure to observe these requirements may invalidate the CE conformance.

■ POWER INPUT RATING & OPERATIONAL RANGE

- Locate the power input rating marked on the product and confirm its operational range as indicated below:
 24 V DC rating: 24 V ±10%, ≤ 0.7 W

■ GENERAL PRECAUTIONS

- Before you remove the unit or mount it, turn off the power supply and input signal for safety.
- Be sure to put the terminal cover on while the power is supplied.

■ ENVIRONMENT

- Indoor use.
- Do not install the unit where it is subjected to continuous vibration. Do not subject the unit to physical impact.
- Environmental temperature must be within -10 to +55°C (14 to 131°F) with relative humidity within 10 to 90% RH in order to ensure adequate life span and operation.

■ FRONT PANEL CONDITIONS OF CONFORMING TO IP66

- Observe the designated panel cutout size (30.5 mm dia.).
- The watertight packing included in the product package must be placed between the body and panel when installing on the panel.
- Fasten the body and panel together with four M4 screws. (Torque: 0.6 – 0.9 N·m)
- Confirm visually that the packing is not contorted or excessively run off the edge after installation.
- When replacement of the watertight packing is needed, consult us.

■ WIRING

- Make sure for safety that only qualified personnel perform the wiring.
- Do not install cables close to noise sources (relay drive cable, high frequency line, etc.).
- Do not bind these cables together with those in which noises are present. Do not install them in the same duct.

■ EX-FACTORY SETTING (/SET)

- Activating “initialization” of Lockout Setting Mode, Ex-factory settings or user’s specified parameters will be deleted and overwritten with the factory default values. Notice that after this, Ex-factory settings will be irrecoverable.

■ AND

- The unit is designed to function as soon as power is supplied, however, a warm up for 10 minutes is required for satisfying complete performance described in the data sheet.

LIGHTNING SURGE PROTECTION

We offer a series of lightning surge protectors for protection against induced lightning surges. Please contact us to choose appropriate models.

COMPONENT IDENTIFICATION

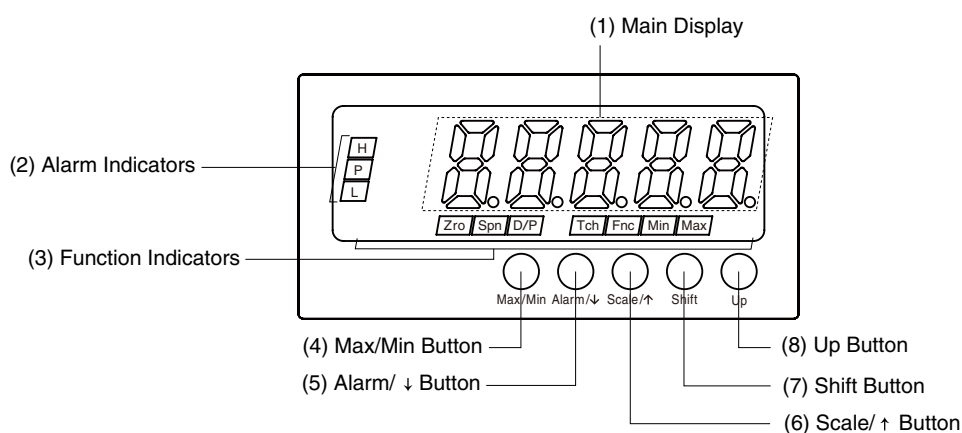

COMPONENT IDENTIFICATION

No.	COMPONENT	FUNCTION
(1)	Main display	Indicates present values, setting values and status of the unit.
(2)	Alarm indicators* ¹	Indicates the comparison result between alarm setting values and present values. L turns on when the L alarm is tripped. H turns on when the H alarm is tripped. P turns on when none of the other alarms is tripped.
(3)	Function indicators	Indicates the status in each setting mode.
(4)	Max/Min button	Used to switch the main display to show the present values, maximum values or minimum values.
(5)	Alarm/↓ button	Used to check the alarm setpoints, to move on to the alarm and other setting modes; or to shift through setting items in each setting mode.
(6)	Scale/↑ button	Used to move on to the initial and other setting modes; or to shift through setting items in each setting mode.
(7)	Shift button	Used to move on to the setting standby status of each setting mode or to shift through display digits in each setting item.
(8)	Up button	Used to change setting values or to select setting values.

*1. Only 'P' indicator turns on when 'No alarm' option is selected for the alarm points parameter. All alarm can be set to Hi trip or Lo trip.

INSTALLATION

■ PANEL MOUNTING unit: mm (inch)

Panel cutout must be such as specified by us. Use watertight packing and unit fixing screws included in the product package.

• Single Mounting

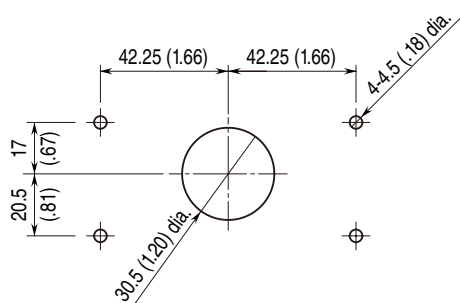

Panel thickness: 1.0 to 3.2 mm

• Clustered Mounting

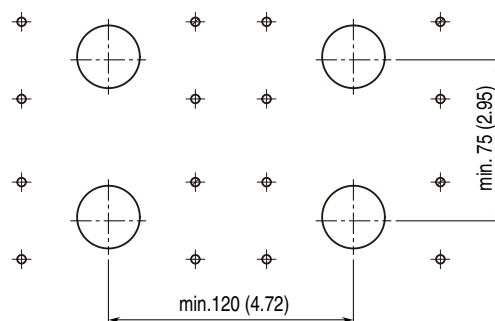

Panel thickness: 1.0 to 3.2 mm

■ HOW TO MOUNT THE UNIT WITH SCREW

Refer to the figure below to fix the unit to the panel before wiring.

Panel thickness: 1.0 – 3.2 mm

Torque: 0.6 – 0.9 N·m

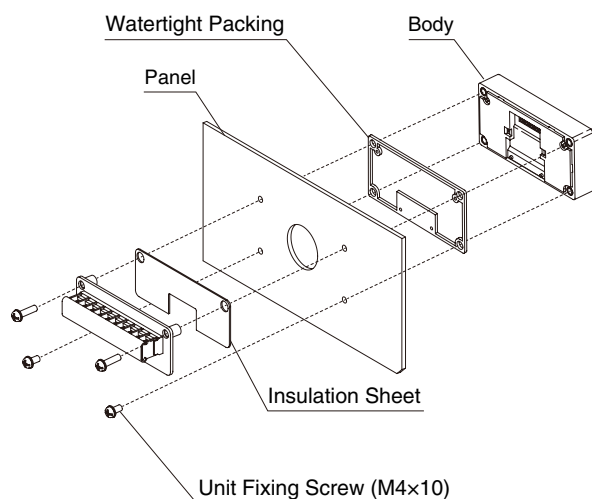

■ CONDITIONS OF CONFORMING TO IP66

- Observe the designated panel cutout size (30.5 mm dia.).
- The watertight packing included in the product package must be placed between the body and panel when installing on the panel.
- Fasten the body and panel together with two M4 × 10 screws at lower two points. (Torque: 0.6 – 0.9 N·m)
- Connect the harness of the body to the connector terminal block.
- The insulation sheet included in the product package must be placed between the panel and terminal block when installing the terminal block.
- Fasten the body and terminal block together with two M4 × 20 screws at upper two points. (Torque: 0.6 – 0.9 N·m)
- Confirm visually that the packing is not contorted or excessively run off the edge after installation.

TERMINAL CONNECTIONS

Connect the unit as in the diagram in the following page or refer to the connection diagram.

■ EXTERNAL DIMENSIONS unit: mm (inch)

■ BODY

• FRONT VIEW

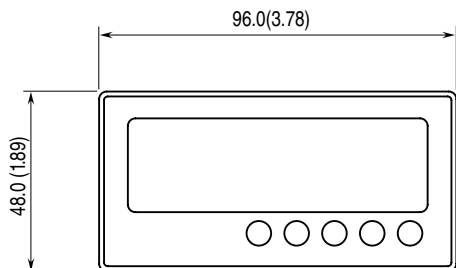

• SIDE VIEW

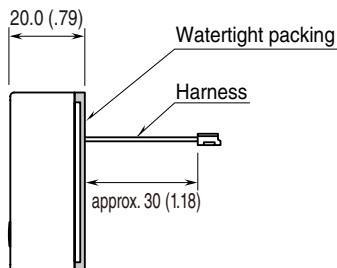

• REAR VIEW

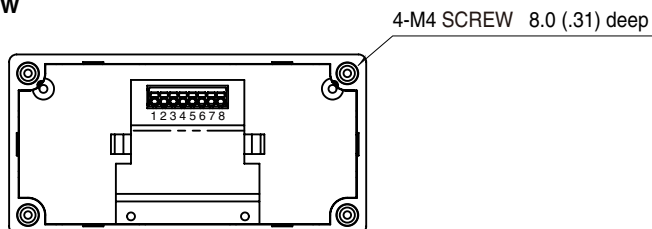

■ TERMINAL BLOCK

• FRONT VIEW

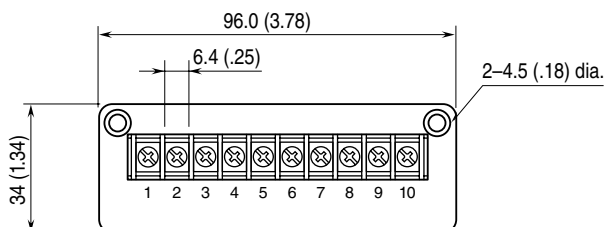

• REAR VIEW

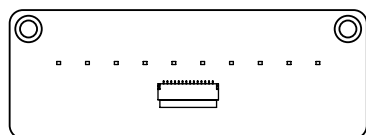

• SIDE VIEW

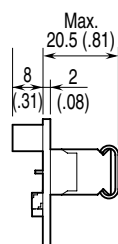

■ CONNECTION DIAGRAM

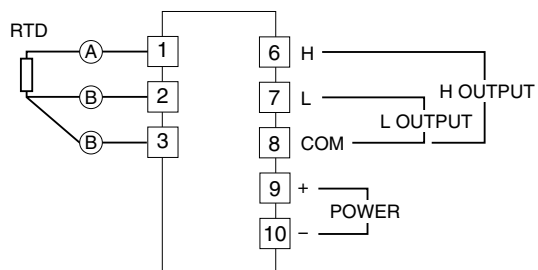

WIRING INSTRUCTIONS

■ SCREW TERMINAL

Torque: 0.6 N·m

■ SOLDERLESS TERMINAL

Refer to the drawing below for recommended ring tongue terminal size. Spade tongue type is also applicable.

Applicable wire size: 0.25 to 1.65 mm²

Recommended manufacturer: Japan Solderless Terminal MFG. Co., Ltd., Nichifu Co., Ltd.

