

# LOOP POWERED DIGITAL PANEL METER

(4 1/2 digit, LED display type)

MODEL **47NLN**

## BEFORE USE ....

Thank you for choosing us. Before use, please check contents of the package you received as outlined below.

If you have any problems or questions with the product, please contact our sales office or representatives.

### ■ PACKAGE INCLUDES:

Digital panel meter .....	(1)
Engineering unit sticker label sheet .....	(1)
Magnet label sheet .....	(1)
Stopper .....	(1)
Unit fixing screw (M4) .....	(4)
Watertight packing .....	(1)

### ■ MODEL NO.

Confirm Model No. marking on the product to be exactly what you ordered.

### ■ INSTRUCTION MANUAL

This manual describes necessary points of caution when you use this product, including installation, connection and basic maintenance procedures.

For detailed explanations to operate and program the module, please refer to Model 47NLN Operating Manual (EM-9563-B), downloadable at our web site.

## POINTS OF CAUTION

### ■ CONFORMITY WITH EU DIRECTIVES

- The actual installation environments such as panel configurations, connected devices, connected wires, may affect the protection level of this unit when it is integrated in a panel system. The user may have to review the CE requirements in regard to the whole system and employ additional protective measures to ensure the CE conformity.

### ■ GENERAL PRECAUTIONS

- Before you remove the unit or mount it, turn off the input signal for safety.

### ■ ENVIRONMENT

- Indoor use.
- Do not install the unit where it is subjected to continuous vibration. Do not subject the unit to physical impact.
- Environmental temperature must be within -10 to +55°C (14 to 131°F) with relative humidity within 10 to 90% RH in order to ensure adequate life span and operation.

### ■ FRONT PANEL CONDITIONS OF CONFORMING TO IP66

- Only screw mounting conforms.
- Observe the designated panel cutout size (30.5 mm dia.).
- The watertight packing included in the product package must be placed between the body and panel when installing on the panel.
- Fasten the body and panel together with four M4 × 10 screws. (Torque: 0.6 – 0.9 N·m)
- Confirm visually that the packing is not contorted or excessively run off the edge after installation.
- When replacement of the watertight packing is needed, consult us.

### ■ WIRING

- Make sure for safety that only qualified personnel perform the wiring.
- Do not install cables close to noise sources (high frequency line, etc.).
- Do not bind these cables together with those in which noises are present. Do not install them in the same duct.

### ■ EX-FACTORY SETTING (/SET)

- Activating “initialization” of Lockout Setting Mode, Ex-factory settings or user’s specified parameters will be deleted and overwritten with the factory default values. Notice that after this, Ex-factory settings will be irrecoverable.

### ■ AND ....

- The unit is designed to function as soon as input signal is supplied, however, a warm up for 10 minutes is required for satisfying complete performance described in the data sheet.

## COMPONENT IDENTIFICATION

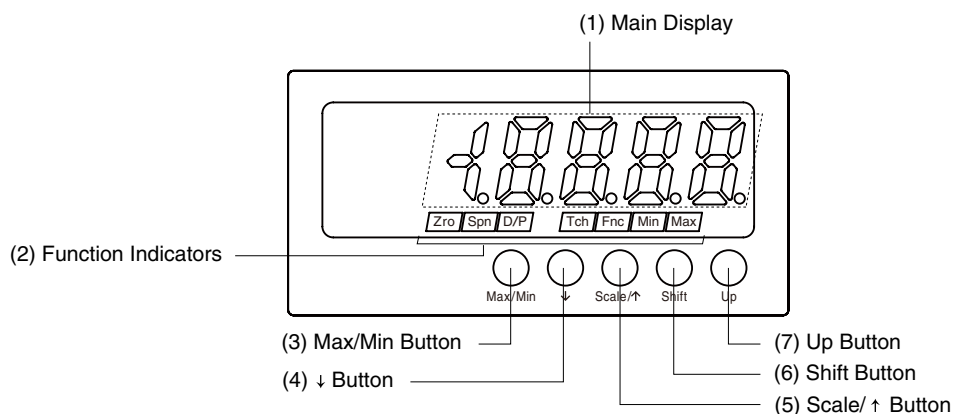

### COMPONENT IDENTIFICATION

No.	COMPONENT	FUNCTION
(1)	Main display	Indicates present values, setting values and status of the unit.
(2)	Function indicators	Indicates the status in each setting mode.
(3)	Max/Min button	Used to switch the main display to show the present values, maximum values or minimum values.
(4)	↓ button	Used to shift through setting items in each setting mode etc.
(5)	Scale/↑ button	Used to move on to the scaling and other setting modes; or to shift through setting items in each setting mode.
(6)	Shift button	Used to move on to the setting standby status of each setting mode or to shift through display digits in each setting item.
(7)	Up button	Used to change setting values, to execute / cancel Forced Zero or to select setting values.

## INSTALLATION

### ■ PANEL MOUNTING

(Conform to degree of protection IP66)

Panel cutout must be such as specified by us. Use water-tight packing and unit fixing screws included in the product package.

#### • Single Mounting unit: mm (inch)

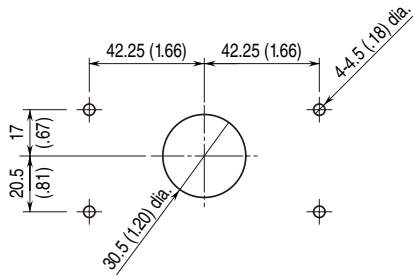

#### • Clustered Mounting unit: mm (inch)

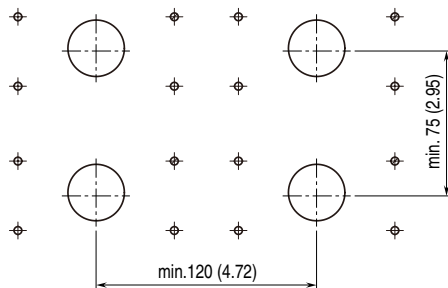

Panel thickness: 1.0 to 3.2 mm

### ■ HOW TO MOUNTING THE UNIT WITH SCREW

Refer to the figure below to fix the unit to the panel before wiring.

**Panel thickness:** 1.0 – 3.2 mm

**Torque:** 0.6 – 0.9 N·m

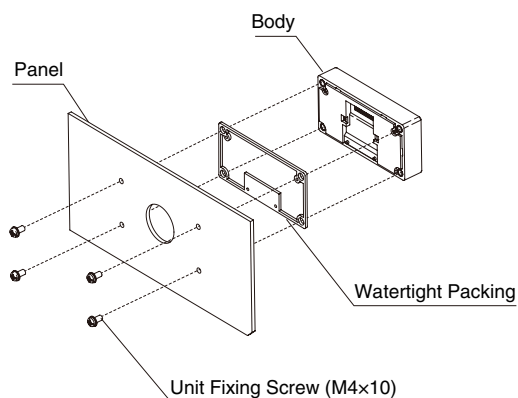

### ■ CONDITIONS OF CONFORMING TO IP66

- Observe the designated panel cutout size (30.5 mm dia.).
- The watertight packing included in the product package must be placed between the unit and a panel when installed to the panel.
- The unit must be fixed with four M4 screws (Torque: 0.6 – 0.9 N·m).
- Confirm visually that the packing is not contorted or excessively run off the edge after installation.

### ■ MAGNET MOUNTING

(Not conform to degree of protection IP66)

Panel cutout is not required. Use magnet sheet and stopper included in the product package.

#### • Clustered Mounting unit: mm (inch)

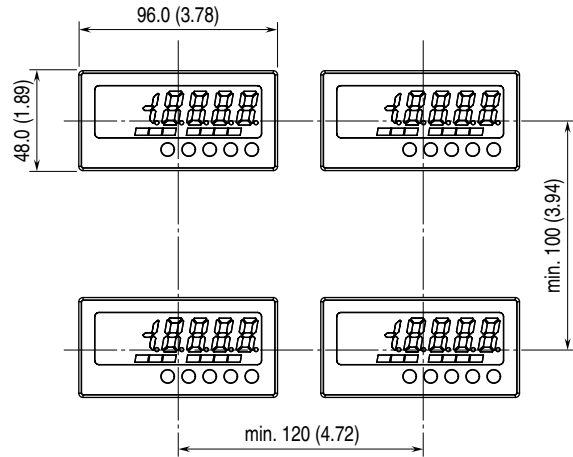

### ■ HOW TO MOUNTING THE UNIT WITH MAGNET

Follow the instruction below to fix the unit after wiring.

- 1) Tear off a protective seal, and attach it to the unit.

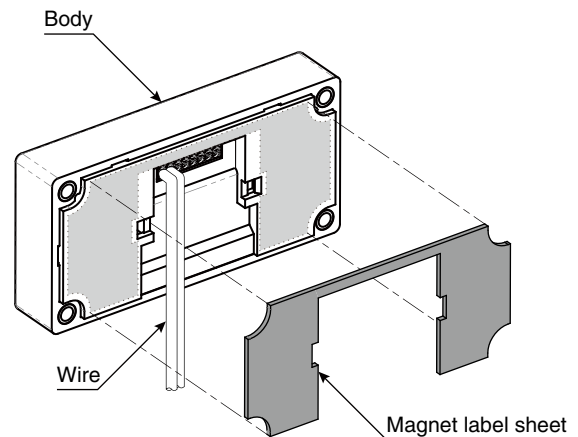

- 2) Attach the stopper to the unit to fix the wire.

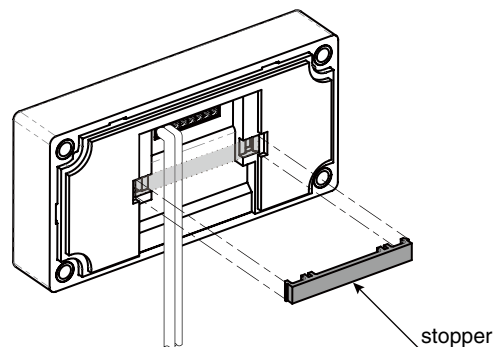

3) Fix the unit to an iron panel.

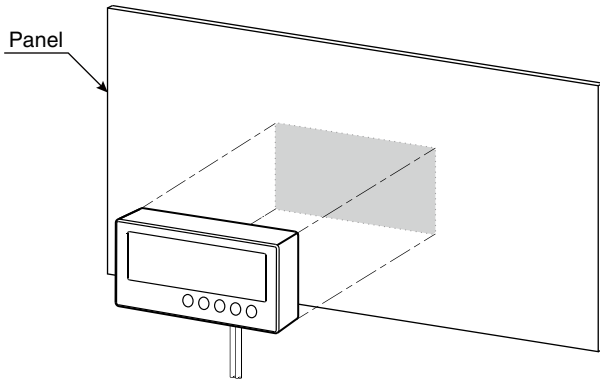

For magnet mounting, DO NOT use where it is subjected to continuous vibration or DO NOT subject the unit to physical impact.

## TERMINAL CONNECTIONS

Connect the unit as in the diagram below or refer to the connection diagram.

### EXTERNAL DIMENSIONS unit: mm (inch)

#### FRONT VIEW

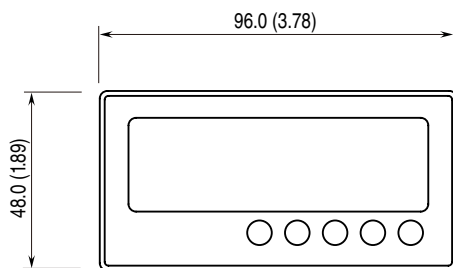

#### SIDE VIEW

##### SCREW MOUNTING

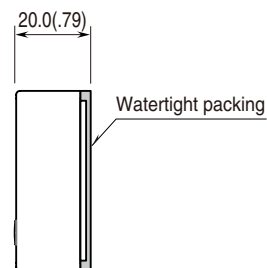

##### MAGNET MOUNTING

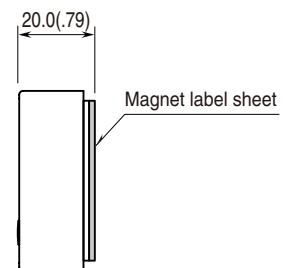

#### REAR VIEW

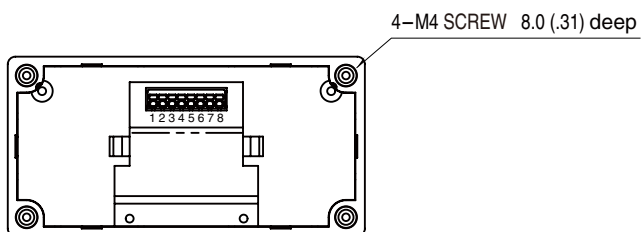

## ■ CONNECTION DIAGRAM

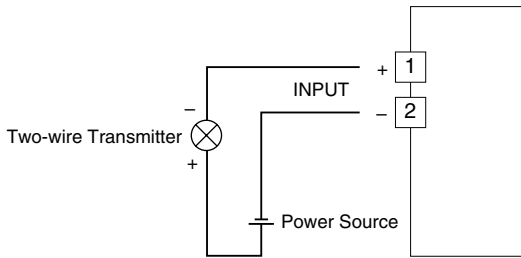

## ■ 4-WIRE CONNECTION EXAMPLE

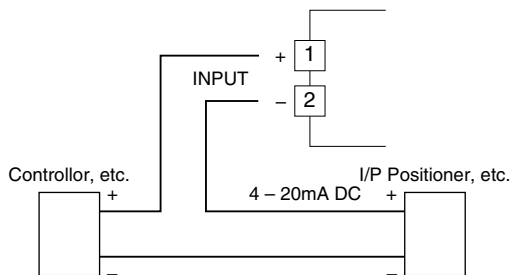

## WIRING INSTRUCTIONS

### ■ APPLICABLE WIRE

- Applicable wire size: 0.2 – 0.5 mm<sup>2</sup>
- Stripped length: 6 mm (0.24")

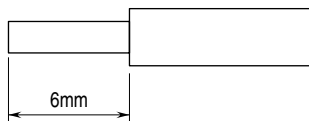

### CAUTION

- Tinning wire ends may cause contact failure and therefore is not recommended.
- Do not use insulating sleeve when solderless terminal (ferrule) is used.
- When mounting with magnet, the sheath of wire must be 2 mm<sup>2</sup> or less.

### ■ WIRING

Use minus screwdriver to connect wire(s) to a tension clamp terminal block.

Blade edge: 0.4 mm (0.02") Blade width: 2 mm (0.08")

Procedures are as follows.

- 1) Insert a minus screwdriver into the dead end to open the spring.

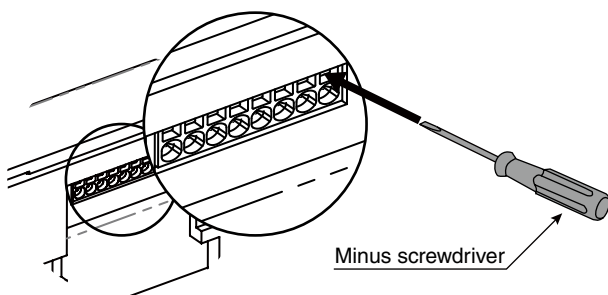

- 2) Insert wire(s) deeply.

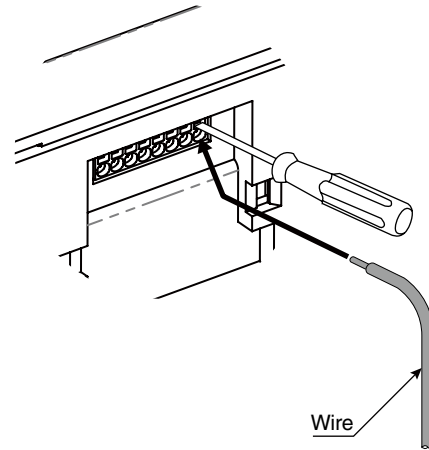

- 3) Pull out the minus screwdriver to fix wire(s).

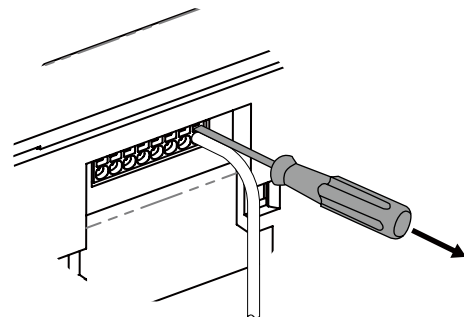

### NOTE

- Take measures to prevent the sheath of wire from being caught in terminal(s) to avoid contact failure.
- Pull the wire(s) lightly to confirm that the wire is not pulled off.

## LIGHTNING SURGE PROTECTION

We offer a series of lightning surge protectors for protection against induced lightning surges. Please contact us to choose appropriate models.