

Digital Panel Meters 47NL Series
CURRENT LOOP SUPPLY DIGITAL PANEL METER
(4 1/2 digit, LED display type)

Model: 47NLDY

OPERATING MANUAL

CONTENTS

1. INTRODUCTION.....	5
1.1 BEFORE USE.....	5
1.2 SAFETY PRECAUTIONS (that must be observed).....	6
1.3 POINTS OF CAUTION.....	8
1.4 COMPONENT IDENTIFICATION.....	10
1.5 INSTALLATION.....	13
1.5.1 EXTERNAL DIMENSIONS	13
1.5.2 INSTALLATION	13
1.6 WIRING INSTRUCTIONS.....	17
1.6.1 CAUTION IN WIRING	17
1.6.2 APPLICABLE WIRE	17
1.6.3 WIRING.....	17
1.6.4 TERMINAL ASSIGNMENT.....	18
1.6.5 WIRING INPUT SIGNAL.....	19
1.6.6 WIRING ALARM OUTPUTS	20
1.6.7 WIRING POWER	21
2. BASIC SETTING AND OPERATION.....	22
2.1 BASIC SETTING	22
2.1.1 BASIC SETTING FLOW.....	22
2.1.2 RELATION AMONG LINEARIZER, INPUT SCALING AND DISPLAY SCALING.....	22
2.1.3 BASIC SETTING PROCEDURE	23
2.2 BASIC SETTING OPERATION AND INSTRUCTIONS	24
2.2.1 BASIC SETTING OPERATION.....	24
2.2.2 INSTRUCTIONS ON BASIC OPERATION.....	26
3. SETTING LINEARIZER.....	27
3.1 LINEARIZER	27
3.1.1 OPERATING PROCEDURE	28
4. SETTING SCALING VALUES	30
4.1 STEP 1. INPUT SCALING ZERO.....	32
4.1.1 OPERATING PROCEDURE	32
4.2 STEP 2. DISPLAY SCALING ZERO	35
4.2.1 OPERATING PROCEDURE.....	35
4.3 STEP 3. INPUT SCALING SPAN.....	38
4.3.1 OPERATING PROCEDURE.....	38
4.4 STEP 4. DISPLAY SCALING SPAN.....	41
4.4.1 OPERATING PROCEDURE.....	41
4.5 STEP 5. DECIMAL POINT POSITION	44
4.5.1 OPERATING PROCEDURE.....	44

5. OPERATION	47
6. PARAMETER CONFIGURATION.....	48
7. SETTING ALARM OUTPUT	53
7.1 ALARM POINT	56
7.1.1 OPERATING PROCEDURE	56
7.2 ALARM SETPOINT	57
7.2.1 ALARM SETPOINT DEFAULT VALUE	57
7.2.2 OPERATING PROCEDURE.....	57
7.3 TRIP ACTION (LO/HI)	59
7.3.1 OPERATING PROCEDURE.....	59
7.4 DEADBAND	61
7.4.1 OPERATING PROCEDURE.....	61
7.5 TRIP DELAY	63
7.5.1 OPERATING PROCEDURE.....	63
7.6 ALARM OUTPUT LOGIC (coil energized or de-energized at alarm).....	65
7.6.1 OPERATING PROCEDURE.....	65
7.7 MAIN DISPLAY BLINKING AT ALARM	67
7.7.1 OPERATING PROCEDURE	67
8. AVERAGING INPUT	69
8.1 OPERATING PROCEDURE	70
9. INDICATING INPUT LESS THRESHOLD VALUE AS 0%.....	71
9.1 LOW-END CUTOUT	72
9.1.1 OPERATING PROCEDURE	72
9.2 LOW-END CUTOUT VALUE.....	74
9.2.1 OPERATING PROCEDURE.....	74
10. ADJUSTING BRIGHTNESS OF DISPLAY	76
10.1 OPERATING PROCEDURE	77
11. GOING BACK AUTOMATICALLY TO MEASURING MODE.....	79
11.1 OPERATING PROCEDURE.....	80
12. ADJUSTING DISPLAY REFRESHING RATE	82
12.1 OPERATING PROCEDURE	83

13. USEFUL FUNCTIONS.....	85
13.1 CONFIRMING ALARM SETPOINTS.....	85
13.2 FORCING THE PRESENT DISPLAY VALUE TO ZERO	86
13.3 RETAINING MAX AND MIN VALUES	87
13.4 LIMITING BUTTON OPERATION.....	89
13.4.1 OPERATING PROCEDURE	89
13.5 TRANSITION TIME TO LOCKOUT SETTING MODE.....	91
13.5.1 OPERATING PROCEDURE	91
14. USER CALIBRATION.....	93
14.1 TEACH CALIBRATION	93
14.1.1 TEACH CALIBRATION FLOW.....	93
14.1.2 OPERATING PROCEDURE.....	94
15. INSPECTION / CLEANING	96
16. TROUBLESHOOTING	97
16.1 ERROR MESSAGES.....	97
16.2 INITIALIZING SETTING VALUES.....	97
16.2.1 OPERATING PROCEDURE	97
16.3 CONFIRMING FIRMWARE VERSION	99
16.3.1 OPERATING PROCEDURE	99
17. APPENDICES.....	100
17.1 SPECIFICATIONS	100
17.2 MODEL NUMBERING.....	102
17.3 PARAMETER LIST	103
17.4 PARAMETER MAP.....	105
17.4.1 OPERATION IN MEASURING MODE.....	105
17.4.2 SCALING SETTING MODE	106
17.4.3 ALARM SETTING MODE.....	107
17.4.4 ADVANCED SETTING MODE.....	108
17.4.5 LOCKOUT SETTING MODE.....	109
17.5 CHARACTER SET	110

1. INTRODUCTION

1.1 BEFORE USE....

Thank you for choosing us. Before use, please check contents of the package you received as outlined below.

■ PACKAGE INCLUDES

Digital panel meter

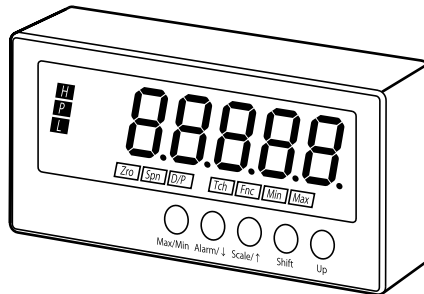

Accessories

<p>Watertight packing (1)</p>	<p>Magnet label sheet (1)</p>	<p>Stopper (1)</p>	<p>Unit fixing screw (4)</p> <p>(screw size: M4 x 10)</p>																																																																	
<p>Engineering unit sticker label sheet (1)</p> <table border="1" data-bbox="264 1339 437 1668"> <tbody> <tr><td>DC</td><td>AC</td><td>mV</td></tr> <tr><td>V</td><td>kV</td><td>μA</td></tr> <tr><td>mA</td><td>A</td><td>kA</td></tr> <tr><td>mW</td><td>W</td><td>kW</td></tr> <tr><td>var</td><td>kvar</td><td>Mvar</td></tr> <tr><td>VA</td><td>kVA</td><td>Ω</td></tr> <tr><td>kΩ</td><td>MΩ</td><td>cm</td></tr> <tr><td>mm</td><td>m</td><td>m/sec</td></tr> <tr><td>mm/min</td><td>cm/min</td><td>m/min</td></tr> <tr><td>m/h</td><td>m/s²</td><td>inch</td></tr> <tr><td>l</td><td>l/s</td><td>l/min</td></tr> <tr><td>l/h</td><td>m²</td><td>m²/sec</td></tr> <tr><td>m³/min</td><td>m³/h</td><td>Nm/h</td></tr> <tr><td>N · m</td><td>N/m²</td><td>g</td></tr> <tr><td>kg</td><td>kg/h</td><td>N</td></tr> <tr><td>kN</td><td>Pa</td><td>kPa</td></tr> <tr><td>MPa</td><td>t</td><td>t/h</td></tr> <tr><td>°C</td><td>°F</td><td>%RH</td></tr> <tr><td>J</td><td>kJ</td><td>MJ</td></tr> <tr><td>rpm</td><td>sec</td><td>min</td></tr> <tr><td>pH</td><td>%</td><td>ppm</td></tr> <tr><td colspan="3">NXXXXXX</td></tr> </tbody> </table>	DC	AC	mV	V	kV	μA	mA	A	kA	mW	W	kW	var	kvar	Mvar	VA	kVA	Ω	kΩ	MΩ	cm	mm	m	m/sec	mm/min	cm/min	m/min	m/h	m/s ²	inch	l	l/s	l/min	l/h	m ²	m ² /sec	m ³ /min	m ³ /h	Nm/h	N · m	N/m ²	g	kg	kg/h	N	kN	Pa	kPa	MPa	t	t/h	°C	°F	%RH	J	kJ	MJ	rpm	sec	min	pH	%	ppm	NXXXXXX			<p>Instruction manual</p>	<p>Ordering Information Sheet</p> <p>(included with the option code 'SET' only)</p>
DC	AC	mV																																																																		
V	kV	μA																																																																		
mA	A	kA																																																																		
mW	W	kW																																																																		
var	kvar	Mvar																																																																		
VA	kVA	Ω																																																																		
kΩ	MΩ	cm																																																																		
mm	m	m/sec																																																																		
mm/min	cm/min	m/min																																																																		
m/h	m/s ²	inch																																																																		
l	l/s	l/min																																																																		
l/h	m ²	m ² /sec																																																																		
m ³ /min	m ³ /h	Nm/h																																																																		
N · m	N/m ²	g																																																																		
kg	kg/h	N																																																																		
kN	Pa	kPa																																																																		
MPa	t	t/h																																																																		
°C	°F	%RH																																																																		
J	kJ	MJ																																																																		
rpm	sec	min																																																																		
pH	%	ppm																																																																		
NXXXXXX																																																																				





■ MODEL NO.

Confirm Model No. marking on the product to be exactly what you ordered.

1.2 SAFETY PRECAUTIONS (that must be observed)

The following signs are used in this manual to provide precautions required to ensure safe usage of the unit. Please understand these signs and graphic symbols, read the manual carefully and observe the description.

The following signs show seriousness of safety hazard or damage occurred when used wrongly with the signs ignored.

 WARNING	Indicates a potentially hazardous situation which, if not avoided, may result in serious injury or death.	
 CAUTION	Indicates a potentially hazardous situation which, if not avoided, may result in injury or in property damage.	
 Indicates prohibitions.	 Indicates mandatory cautions.	 Indicates cautions.

WARNING



CAUTION

For safety, make sure that wiring is performed by qualified personnel only.

- Failure to do so may result in a fire, electric shock or injury.



CAUTION
ELECTRIC SHOCK

Do not touch the terminals while the power is on.

- Doing so may result in electric shock.



MANDATORY
CAUTION

Check the connection diagram carefully before wire connection.

- Failure to do so may result in malfunction, a fire or electric shock.



MANDATORY
CAUTION

Provide safety measures outside of the unit to ensure safety in the whole system if an abnormality occurs due to malfunction of the unit or another external factor affecting the unit's operation.



PROHIBITION
TO BE WET

Do not splash water on the unit except for the front panel installed correctly.

- Doing so may result in a fire, electric shock or injury.



MANDATORY
CAUTION

Stop using the unit immediately if smokes, unusual smell or abnormal noises come(s) from it.

- Using the unit continuously may result in a fire or electric shock.



MANDATORY
CAUTION

Stop using the unit if it is dropped or damaged.

- Using the unit continuously may result in a fire or electric shock.



PROHIBITION

Do not throw the unit into the fire.

- Doing so may result in rupture of the electronic component.

CAUTION



PROHIBITION
TO DISCOMPOSE

- Never discompose or remodel the unit.
- Doing so may result in electric shock, malfunction or injury.



PROHIBITION

- Do not connect or remove the unit while its power is on.
- Doing so may result in electric shock, malfunction or injury.



MANDATORY
CAUTION

- Do not allow fine shavings or wire scraps to enter the unit in machining screws or wiring.
- Doing so may result in malfunction of the unit.



PROHIBITION

- Do not press buttons with a pointed object.
- Doing so may result in malfunction of the unit.



PROHIBITION

- Do not pull the wires connecting to the unit.
- Doing so may result in electric shock, damage of the unit or injury.



PROHIBITION

- Do not use the unit in the atmosphere where combustible gas is present.
- Doing so may result in inflammation, ignition or smoke.

1.3 POINTS OF CAUTION

■ CONFORMITY WITH EU DIRECTIVES

- Our products conforming to the EU Directives conforms to the standards required based on the premise that they are built into various equipment, apparatus or control panels to use. Because the EMC performance depends on the configuration, wiring or arrangement of the equipment, apparatus and control panels you build, it is necessary for you to make such equipment, apparatus or control panels to conform finally to the CE Marking by yourselves.

CAUTION

This product conforms to the EMC Directive for electrical and electronic apparatus intended for use in industrial environments. If it is used in the residential environments, it may cause radio interference, and the user is requested to take appropriate measures.

■ ENVIRONMENT

Install the unit within the installation specifications.

- Indoors use.
- Environmental temperature must be within -10 to +55°C (14 to 131°F) with relative humidity within 10 to 90% RH without condensing.
- Provide sufficient space around the unit for heat dissipation.
- For screw mounting, mount the unit to a panel between 1.0 and 3.2 mm thick.
- Install the unit in a well-ventilated place in order to prevent internal temperature rise.
- Refer to “Clustered mounting” to install several units. In mounting the unit with other equipment side by side, provide sufficient space between them, according to the dimensions in the clustered mounting.
- Do not use the unit under the following environments:
 - Where the unit is exposed to direct sunlight, rain or wind. (The unit is not designed for outdoor use.)
 - Where condensation may occur due to extreme temperature changes.
 - Where corrosive or flammable gas is present.
 - Where heavy dust, iron powder or salt is present in the air.
 - Where organic solvent such like benzene, thinner, and alcohol, or strong alkaline materials such like ammonia and caustic soda may attach to the unit, or where such materials are present in the air.
 - Where the unit is subject to continuous vibration or physical impact.
 - Where there are high-voltage lines, high-voltage equipment, power lines, power equipment, equipment with transmission unit such like a ham radio equipment, or equipment generating large switching surges around the unit.

■ WIRING

- In order to prevent potential electric shock, wire the unit after turning off the power supply and making sure that the power is not supplied to the cable.
- Be sure to confirm the name and polarity of each terminal before wiring to it.
- Do not connect anything to unused terminals.

■ HANDLING CAUTIONS

- The unit is designed to function as soon as power is supplied, however, a warm up for 10 minutes is required for satisfying complete performance described in the data sheet.
- Use the unit within the noted supply power voltage and rated load.
- The last measured values are held in mode transition. Take this into consideration when configuring the control system.
- Clean the surface of the unit with wet soft cloth. Do not use organic solvent such like benzene, thinner and alcohol. Doing so may result in deformation or discoloration of the unit.
- When abnormality is found such like smokes, unusual smell and abnormal noises coming from the unit, immediately cut the power supply and stop using it.

■ **TO ENSURE DUSTPROOF AND WATERPROOF** (degree of protection IP66)

To ensure dustproof and waterproof for front panel follow conditions below.

- Only screw mounting conforms.
- Observe the designated panel cutout size (30.5 mm dia.) specified by us.
- The watertight packing included in the product package must be placed between the body and panel when installing on the panel.
- Fasten the body and panel together with four M4 × 10 screws (torque: 0.6 – 0.9 N·m).
- After installation, confirm that there are no following abnormalities.
 - The packing is contorted.
 - There are some spaces between front panel and panel.
 - The packing is run off the edge.
 - The packing is cut off.
 - There are foreign objects sticking.
- When replacement of the watertight packing is needed, consult us.

1.4 COMPONENT IDENTIFICATION

■ FRONT VIEW

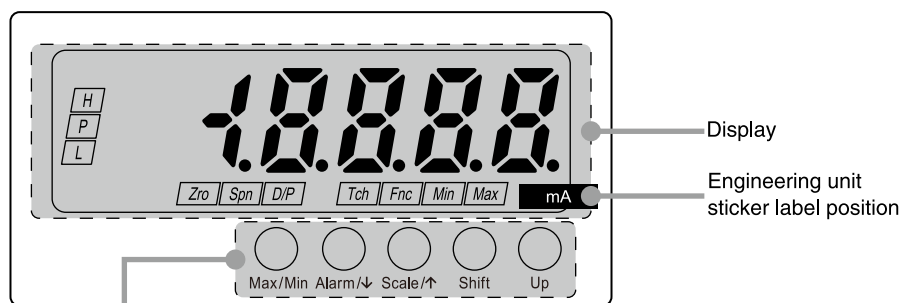

BUTTON	FUNCTION
Max/Min	Used to switch the main display to show the present value, MAX value or MIN value, and to reset the MAX and MIN values. Also used to cancel a set item.
Alarm/↓	Used to confirm the alarm setpoints, to move on to the alarm and other setting modes, or to shift through setting items in each setting mode.
Scale/↑	Used to move on to the scaling and other setting modes, or to shift through setting items in each setting mode.
Shift	Used to move on to the setting standby status of each setting mode and to shift through display digits in each setting item.
Up	Used to change setting values in a setting standby mode and to execute/cancel Forced Zero in Measuring Mode.

NOTE

- The engineering unit sticker label position is our recommended position.
- When an engineering unit is specified by the Ordering Information Sheet, the unit(s) will be shipped with the sticker label put on the above position.

■ DISPLAY

COMPONENT	FUNCTION
Main display	Indicates present, MAX and MIN values, parameters, setting values and error codes.

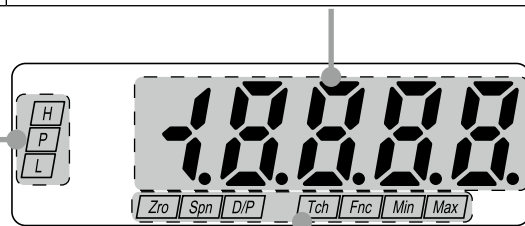

INDICATOR	MODE	FUNCTION	INDICATOR	MODE	FUNCTION
Alarm	Setting	Indicates parameters in Alarm Setting Mode. (Refer to 7. SETTING ALARM OUTPUT.)	Function	Setting	Indicates parameters in each mode. 'Zro', 'Spn', 'D/P', 'Tch' and 'Fnc' indicators turn on in combination depending on the parameters.
	Confirming alarm setpoints	'H' or 'L' indicator blinks in confirming each alarm setpoint. (Refer to 13.1 CONFIRMING ALARM SETPOINTS.)			Teach Calibration. 'Zro' or 'Spn' indicator turns on and 'Tch' indicator blinks. (Refer to 14.1 TEACH CALIBRATION.)
	Measuring	Indicates the comparison result between alarm setting values and present values. 'H' indicator turns on when the H alarm is tripped. 'L' indicator turns on when the L alarm is tripped. 'P' indicator turns on when none of the other alarms is tripped.			'Max' and 'Min' indicators blink when a parameter is within invalid range while setting.
			Measuring		Indicates Forced Zero mode. 'Zro' and 'Fnc' indicators turn on. (Refer to 13.2 FORCING THE PRESENT DISPLAY VALUE TO ZERO.)
					Indicates MAX or MIN value. 'Max' or 'Min' indicator turns on. (Refer to 13.3 RETAINING MAX AND MIN VALUES.)

■ TOP VIEW

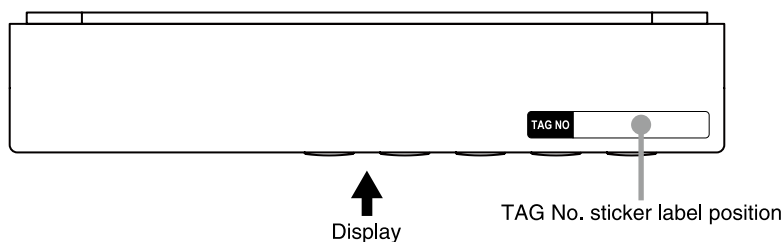

NOTE

- The tag No. label sticker position is our recommended position.
- When a tag No. is specified, the unit(s) will be shipped with the tag No. sticker label put on the above position. Max. 17 alphanumeric characters can be specified. Please consult us.

■ BOTTOM VIEW

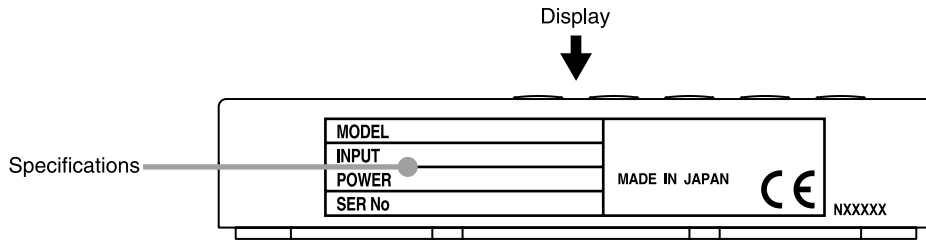

NOTE

Contents of the specification label depend on the specifications.

■ REAR VIEW

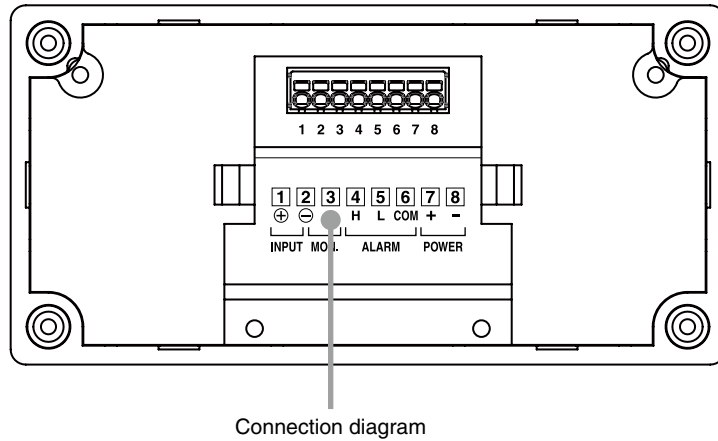

1.5 INSTALLATION

1.5.1 EXTERNAL DIMENSIONS

unit: mm (inch)

■ FRONT VIEW

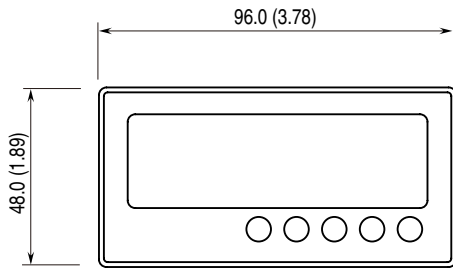

■ SIDE VIEW

• SCREW MOUNTING

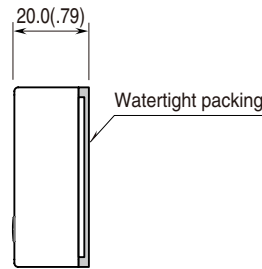

• MAGNET MOUNTING

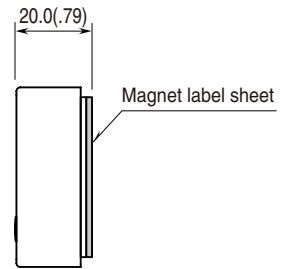

■ REAR VIEW

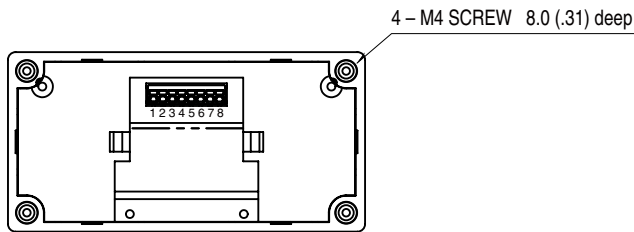

1.5.2 INSTALLATION

■ PANEL MOUNTING (Conform to degree of protection IP66)

Panel cutout must be such as specified by us.

• Single Mounting

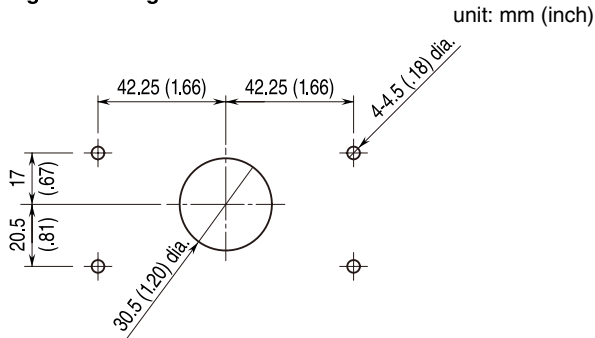

• Clustered Mounting

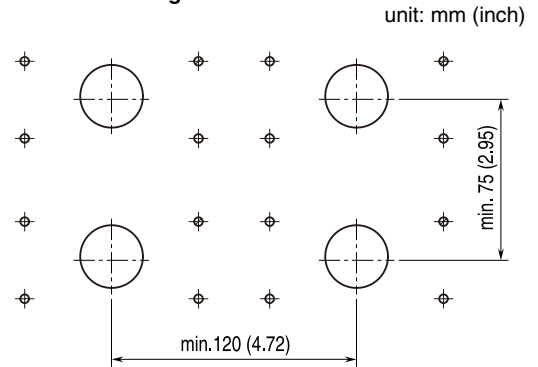

IMPORTANT

Remove burrs from the panel cut surface so that they may not damage the wires.

Use watertight packing and unit fixing screws included in the product package.
Fix the unit to the panel before wiring according to the following procedure.

Panel thickness: 1.0 – 3.2 mm

(1) Mount the watertight packing to the body. Fit the concave part of the watertight packing in the convex part of the body.

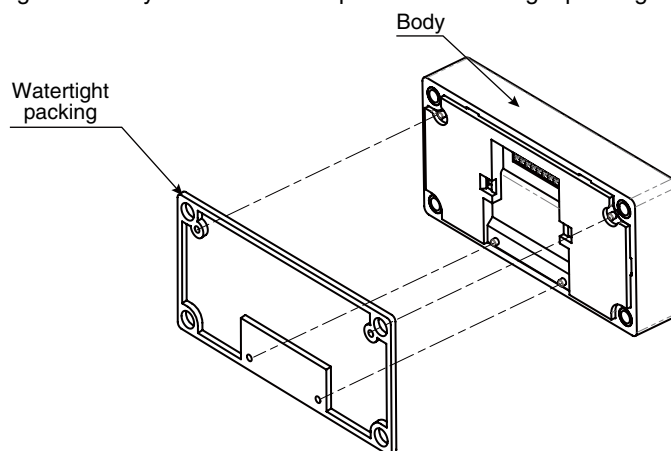

(2) Fix the screws (M4 × 10) to the panel.

Torque: 0.6 – 0.9 N·m

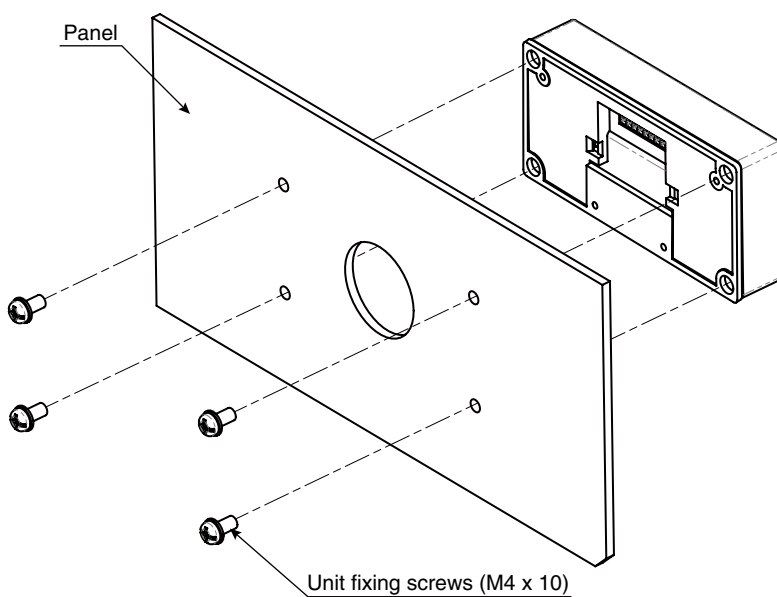

IMPORTANT

To conform to degree of protection IP66, confirm visually that the packing is not contorted, cut off or excessively run off the edge after installation.

■ **MAGNET MOUNTING** (Not conform to degree of protection IP66)

Panel cutout is not required.

Use magnet sheet and stopper included in the product package.

Follow the instruction below to fix the unit after wiring.

- (1) Tear off a protective seal, and attach it to the unit.

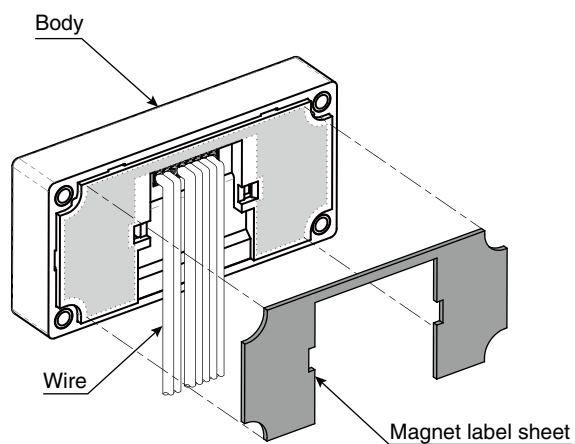

- (2) Attach the stopper to the unit to fix the wire.

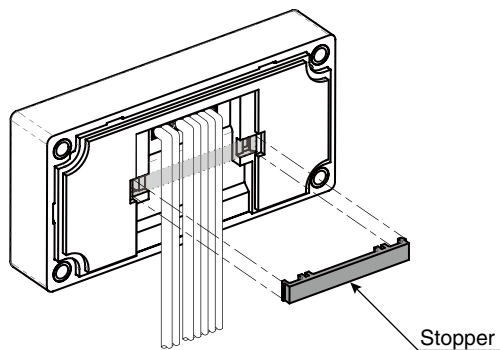

(3) Fix the unit to an iron panel.

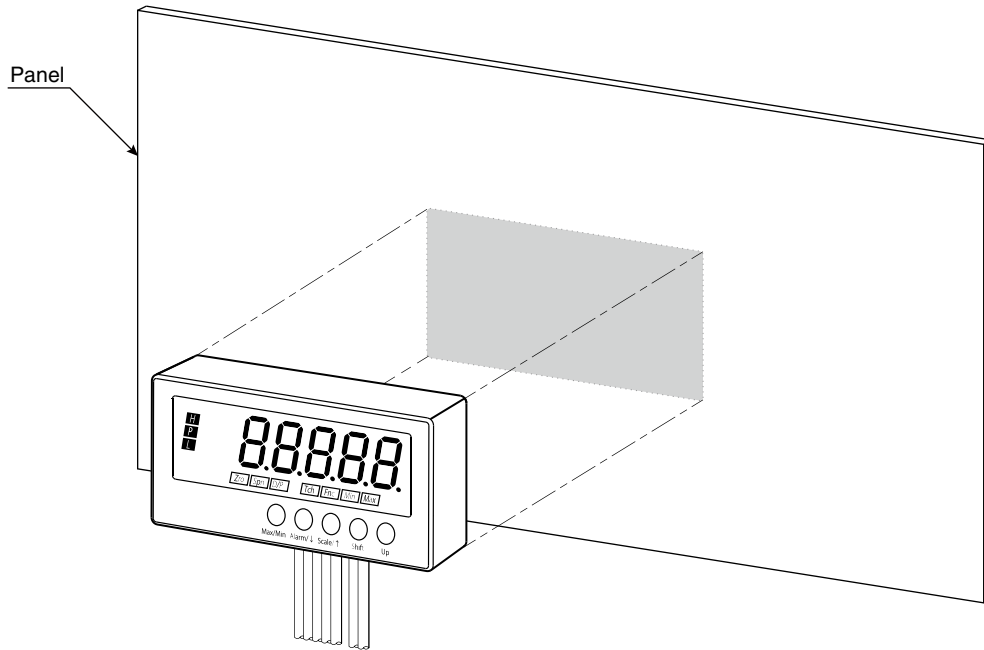

IMPORTANT

- For magnet mounting, DO NOT use where it is subjected to continuous vibration or DO NOT subject the unit to physical impact.
- The sheath of wire must be 2 mm² or less.

• Clustered Mounting

unit: mm (inch)

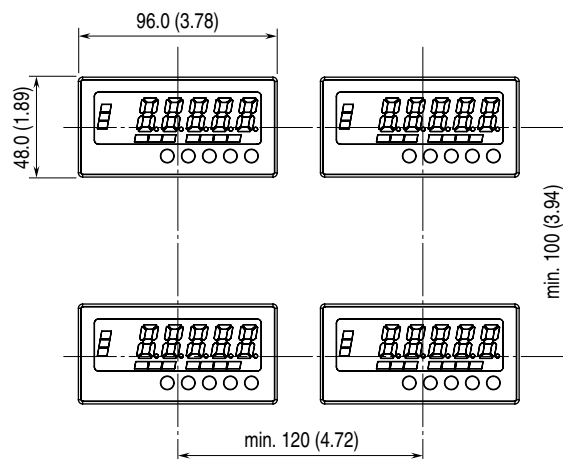

1.6 WIRING INSTRUCTIONS

1.6.1 CAUTION IN WIRING

- For safety, make sure that wiring is performed by qualified personnel only.
- In order to prevent potential electric shock, wire the unit after turning off the power supply and making sure that the power is not supplied to the cable.
- Be sure to confirm the name and polarity of each terminal before wiring to it.
- Do not connect anything to unused terminals.
- We offer a series of lightning surge protectors for protection against induced lightning surges. Please contact us to choose appropriate models.

1.6.2 APPLICABLE WIRE

- Applicable wire size: 0.2 – 0.5 mm²
- Stripped length: 6 mm (0.24")

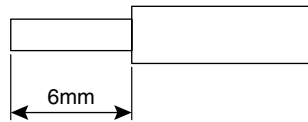

IMPORTANT

- Tinning wire ends may cause contact failure and therefore is not recommended.
- Do not use insulating sleeve when solderless terminal (ferrule) is used.
- When mounting with magnet, the sheath of wire must be 2 mm² or less.

1.6.3 WIRING

Use minus screwdriver to connect wire(s) to a tension clamp terminal block.

Blade edge: 0.4 mm (0.02")
Blade width: 2 mm (0.08")
Procedures are as follows.

- (1) Insert a minus screwdriver into the dead end to open the spring.

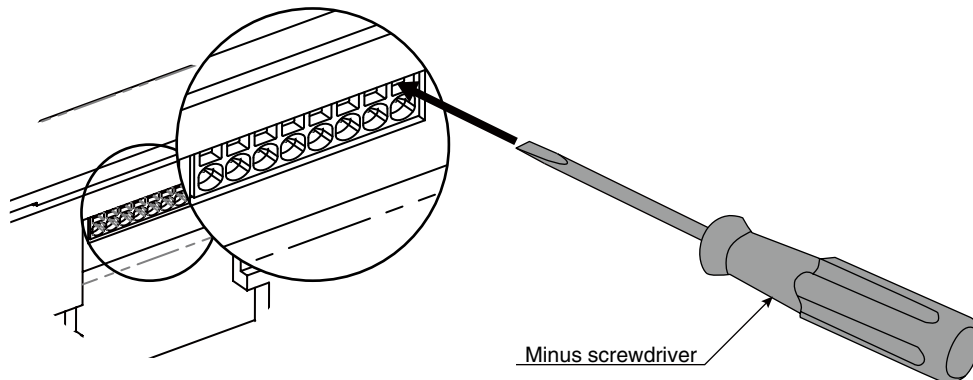

(2) Insert wire(s) deeply.

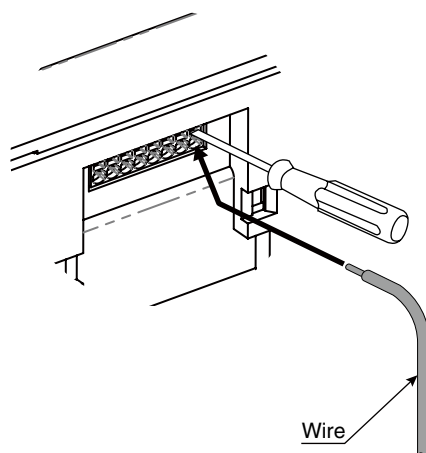

(3) Pull out the minus screwdriver to fix wire(s).

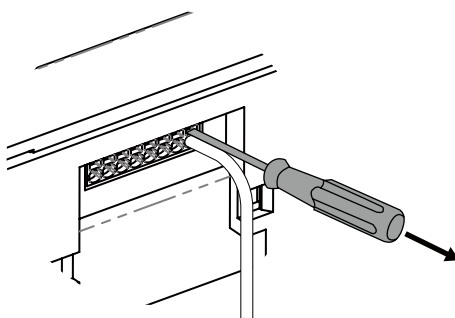

IMPORTANT

- Take measures to prevent the sheath of wire from being caught in terminal(s) to avoid contact failure.
- Pull the wire(s) lightly to confirm that the wire is not pulled off.

1.6.4 TERMINAL ASSIGNMENT

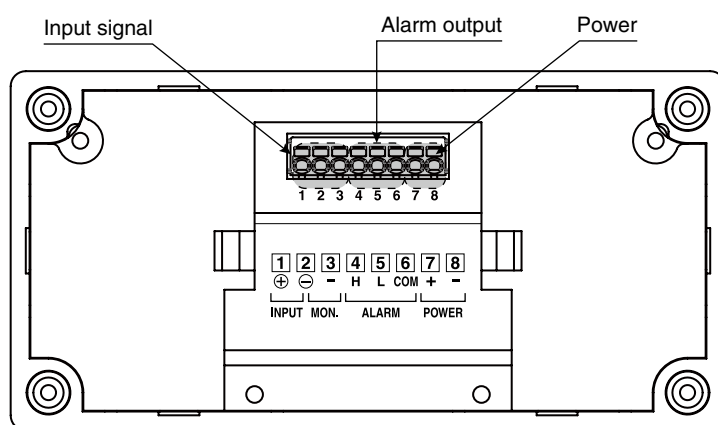

1.6.5 WIRING INPUT SIGNAL

Connect a 2-wire transmitter.

OUTPUT VOLTAGE	CURRENT RATING	SHORTCIRCUIT PROTECTION	
		CURRENT LIMITED	PROTECTED TIME DURATION
24 – 28 V DC with no load 18 V DC minimum at 20 mA	≤ 22 mA DC	35 mA max.	No limit

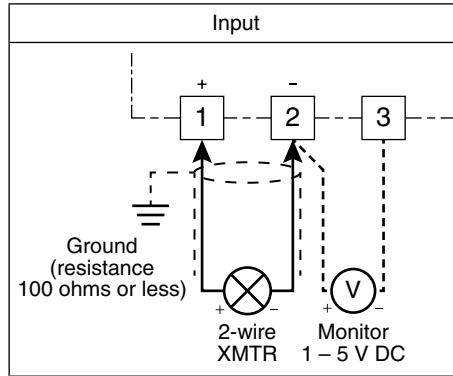

IMPORTANT

- Be sure to confirm the input polarity in wiring. Wrong connection may result in malfunction of the unit.
- In order to prevent potential electric shock, wire the unit after cutting the input signal and making sure that the power is not supplied to the cable.
- Take measures to reduce noise as much as possible, e.g. by using shielded twisted pair wires for the input signal. Ground the input shield to the most stable earth to prevent noise troubles.
- Connect a 2-wire transmitter with the current rating within the specifications.
- Do not connect anything to unused terminals.

NOTE

- Calculate supply power to a 2-wire transmitter using minimum voltage 18 V DC at 20 mA DC load. The voltage after deducting voltage drop by connected reception resistance 250 Ω and leadwire resistance from 18 V DC will be supply power to the 2-wire transmitter.
- You can check 4 – 20 mA DC signal from a 2-wire transmitter with the monitor terminals, converted into 1 – 5 V DC voltage signal with an internal resistor 250 Ω. It is convenient for loop testing or at abnormal condition. Use the terminals only for monitoring, not as output.

1.6.6 WIRING ALARM OUTPUTS

Two alarm contacts are output.

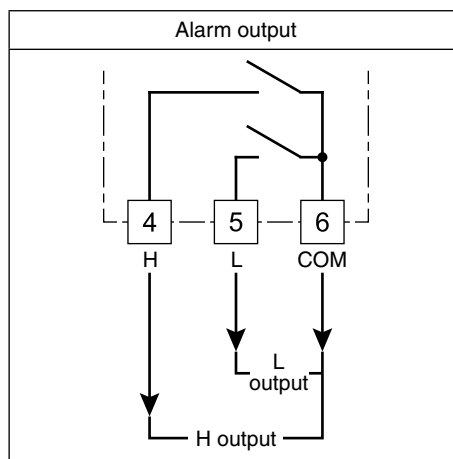

IMPORTANT

- Connect load within the specifications.
- With inductive load such like an external relay or a motor, insert a CR circuit, a diode or a varistor in parallel to protect the contacts and eliminate noise.

NOTE

Example of contact protection circuit with inductive load

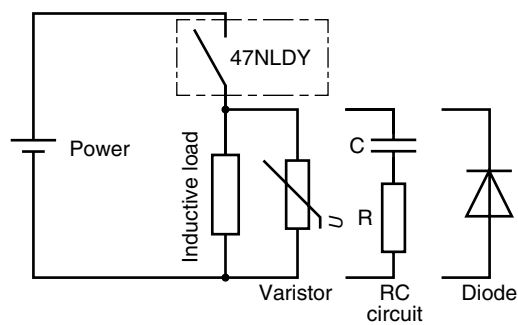

1.6.7 WIRING POWER

Connect DC power. DC power specifications are as shown in the following table.

CODE	RATING	PERMISSIBLE RANGE
R	24 V DC	±10% 2.2 W or less

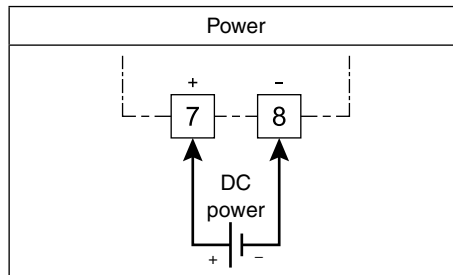

IMPORTANT

- For safety, make sure that wiring is performed by qualified personnel only.
- In order to prevent potential electric shock, wire the unit after turning off the power supply and making sure that the power is not supplied to the cable.
- Be sure to confirm the polarity in wiring.

2. BASIC SETTING AND OPERATION

2.1 BASIC SETTING

This section describes flow and procedure of the basic setting.

The following shows the flow and procedure to set the linearizer to square root extraction, the input to 4 – 20 mA DC and the display to 0.0 – 1000.0 m³ as an example.

2.1.1 BASIC SETTING FLOW

The basic setting is as shown in the following flowchart.

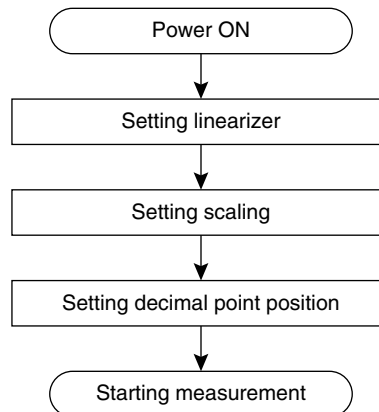

2.1.2 RELATION AMONG LINEARIZER, INPUT SCALING AND DISPLAY SCALING

The relation among linearizer, input scaling and display scaling is as shown in the following figure and charts.

■ Linear

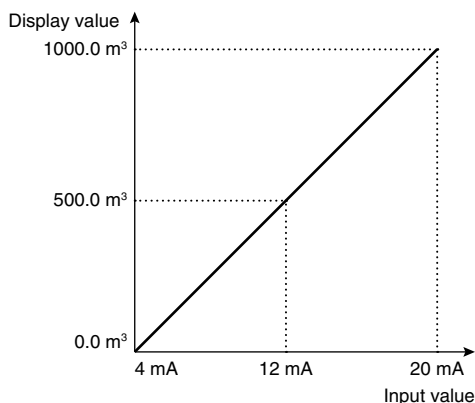

■ Square root extraction

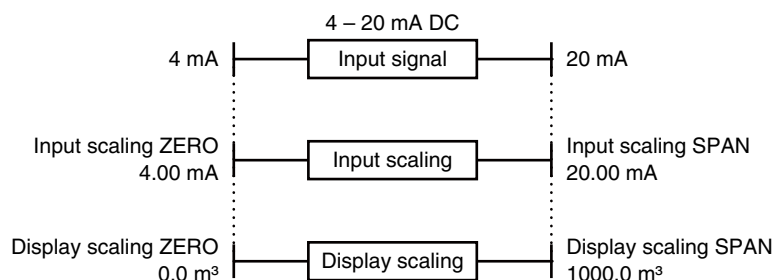
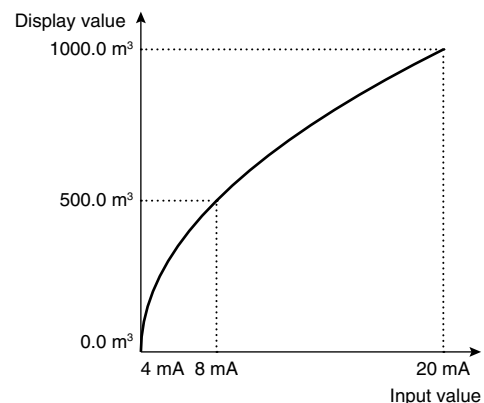

Linearizer: indicating linear input signal or its square root

Input scaling: 0% input value (input scaling ZERO) and 100% input value (input scaling SPAN)

Display scaling: 0% display value (display scaling ZERO) and 100% display value (display scaling SPAN)

2.1.3 BASIC SETTING PROCEDURE

The following shows the procedure to set the linearizer to square root extraction, the input to 4 – 20 mA DC and the display to 0.0 – 1000.0 m³ as an example. Set values meeting signals of the equipment to use. Refer to 3. SETTING LINEARIZER for details of setting.

■ PARAMETER LIST FOR BASIC SETTING

Parameters used in the basic setting are as shown in the following table.

PARAMETER	SETTING VALUE	FUNCTION INDICATOR	SETTING
Linearizer	SQRT	D/P	Square root extraction
Input scaling ZERO	04.00	Zro, Tch	0% input: 4.00 mA
Display scaling ZERO	0000 ^{*1}	Zro, D/P	0% display: 0.0 m ³
Input scaling SPAN	20.00	Spn, Tch	100% input: 20.00 mA
Display scaling SPAN	10000 ^{*1}	Spn, D/P	100% display: 1000.0 m ³
Decimal point position	000.0	D/P	1 decimal place (10 ⁻¹)

*1 The decimal point position depends on the decimal point position setting.

■ BASIC SETTING PROCEDURE

The basic setting procedure is as follows.

- 1 Confirm the wiring, turn on the power and move on to Scaling Setting Mode (measurement stopped).**
 - Hold down Scale/↑ button for 3 seconds or more.
- 2 Set linearizer.**
 - Press Shift button to shift the display into the setting standby mode and Up button to select the linearizer.
- 3 Set scaling values in the order of input scaling ZERO, display scaling ZERO, input scaling SPAN and display scaling SPAN.**
 - Press Alarm/↓ or Scale/↑ button to apply the new setting and go to the next or previous parameter setting.
 - Press Shift button to shift the display into the setting standby mode.
 - Press Shift button to go to the next digit and Up button to change the blinking value.
- 4 Set decimal point position.**
 - Press Alarm/↓ or Scale/↑ button to apply the new setting and go to the next or previous parameter setting.
 - Press Shift button to shift the display into the setting standby mode and Up button to select the decimal point position.
- 5 Return to Measuring Mode (measurement started).**
 - Hold down Alarm/↓ or Scale/↑ button for 3 seconds or more to apply the new setting and return to Measuring Mode.

2.2 BASIC SETTING OPERATION AND INSTRUCTIONS

This section describes basic operation and instructions when setting parameters.

2.2.1 BASIC SETTING OPERATION

Parameters can be grouped into three setting types, “numerical value setting,” “setting value selection” and “decimal point position selection”. Basic operation of each type is as shown below.

■ NUMERICAL VALUE SETTING

1 Press Shift button to shift the display into the setting standby mode.

- The most significant digit starts blinking.

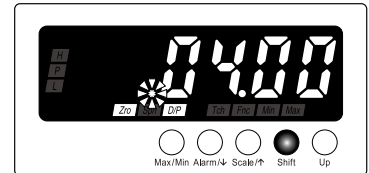

2 Press Shift and Up buttons to set a numerical value.

- Press Shift button to go to the next digit.
- Press Up button to change the blinking value.

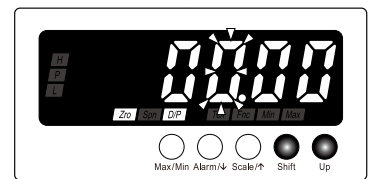

3 Press Alarm/↓ or Scale/↑ button to apply the new setting.

- The next or previous parameter setting is indicated.

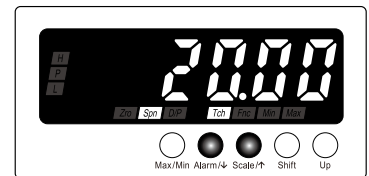

*1 Display depends on the settings.

NOTE

■ SHIFTING DIGITS

Each time pressing Shift button, the blinking digit moves to the right.

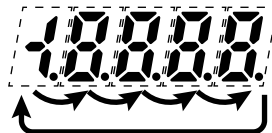

■ SETTING A NUMERICAL VALUE

- Each time pressing Up button, the numeral is incremented by 1. In setting an alarm setpoint, the indication following '9' will be '-'.
- The negative sign (-) must be set to the leftmost digit. For example, set '-04.00' instead of '-4.00'.

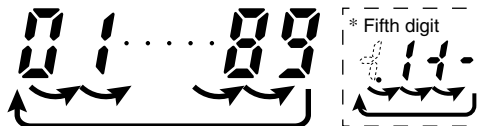

■ SETTING VALUE SELECTION

1 Press Shift button to shift the display into the setting standby mode.

- The current set value starts blinking.

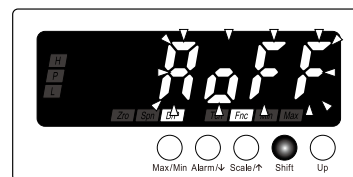

2 Press Up button to select your desired setting value.

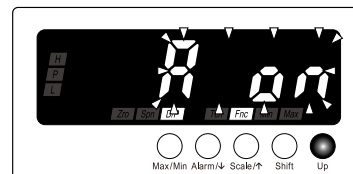

3 Press Alarm/↓ or Scale/↑ button to apply the new setting.

- The next or previous parameter setting is indicated.

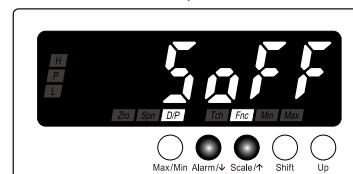

*1 Display depends on the settings.

■ DECIMAL POINT POSITION SELECTION

1 Press Shift button to shift the display into the setting standby mode.

- The current set value starts blinking.

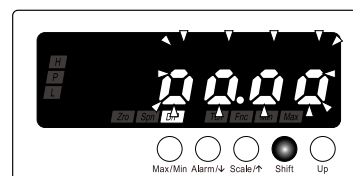

2 Press Up button to select a desired decimal point position.

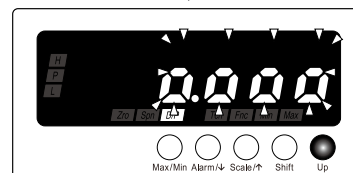

3 Press Alarm/↓ or Scale/↑ button to apply the new setting.

- The next or previous parameter setting is indicated.

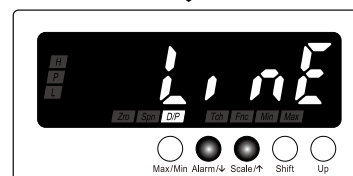

*1 Display depends on the settings.

NOTE

■ MOVING THE DECIMAL POINT

Pressing Up button moves the decimal point one place to the left.

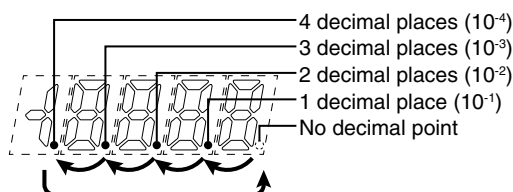

■ DECIMAL POINT POSITION

“No decimal point” to “4 decimal places” can be selected in the decimal point position setting.

SETTING VALUE	FUNCTION	SETTING VALUE	FUNCTION
0.0000	No decimal point	0.000	3 decimal places (10^{-3})
0.000	1 decimal place (10^{-1})	0.0000	4 decimal places (10^{-4})
0.0000	2 decimal places (10^{-2})		

2.2.2 INSTRUCTIONS ON BASIC OPERATION

■ INVALID PARAMETERS

- ‘Max’ and ‘Min’ indicators start blinking when a parameter is within invalid range (following cases). Return the setting within the valid range.
 - In setting an input scaling value beyond the setting range, or setting ‘input scaling ZERO \geq input scaling SPAN’.
 - In setting ‘display scaling ZERO = display scaling SPAN’.
 - In setting the negative sign (-) to a digit other than the leftmost one.

■ IF THE FRONT BUTTONS ARE LEFT UNTOUCHED...

- The display goes back automatically to Measuring Mode without applying the last changes after the specified time period (default: 60 sec.) while it is in the setting standby mode.
- The display goes back automatically to Measuring Mode after the specified time period (default: 60 sec.) while it is in one of the other modes.
- The setting time out is configurable. (Refer to 11. GOING BACK AUTOMATICALLY TO MEASURING MODE.)

■ TO ABORT A SETTING...

- Hold down Max/Min button for 3 seconds or more to return to Measuring Mode without applying the last changes while the display is in the setting standby mode.
- If you get lost in a setting mode, you can execute initialization. (Refer to 16.2 INITIALIZING SETTING VALUES.)

■ IN MOVING ON TO EACH SETTING MODE FROM MEASURING MODE

- The last values of the alarm outputs before mode transition are held.

■ ORDER TO DISPLAY PARAMETERS

- Refer to 6. PARAMETER CONFIGURATION for details.

3. SETTING LINEARIZER

3.1 LINEARIZER

The linear input signal or its square root can be indicated.

■ LINEARIZER

DISPLAY	FUNCTION	DEFAULT VALUE
Line	Linear	Line
Sqrt	Square root extraction	

■ RELATION BETWEEN INPUT SIGNAL AND DISPLAY VALUE

• Linear

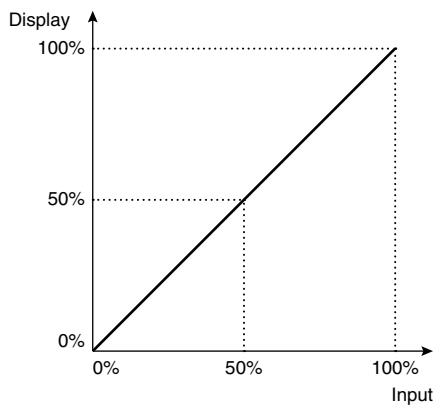

$X_o = X_i$
 X_i : input (%)
 X_o : display (%)

• Square root extraction

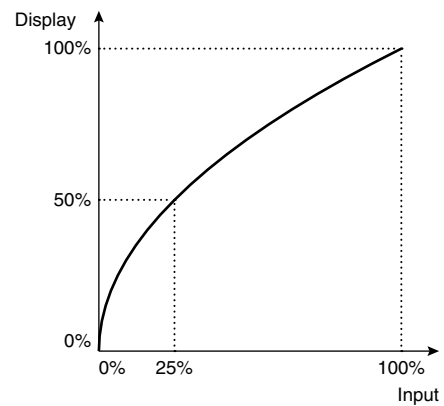

$X_o = \sqrt{X_i}$
 X_i : input (%)
 X_o : display (%)

NOTE

- X_i : percentage of input span (input scaling SPAN - input scaling ZERO)
- X_o : percentage of display span (display scaling SPAN - display scaling ZERO)
- With square root extraction, display error or fluctuation around the input 0% may be increased. Set low-end cutout in such a case. Refer to 9. INDICATING INPUT LESS THRESHOLD VALUE AS 0% for details.

3.1.1 OPERATING PROCEDURE

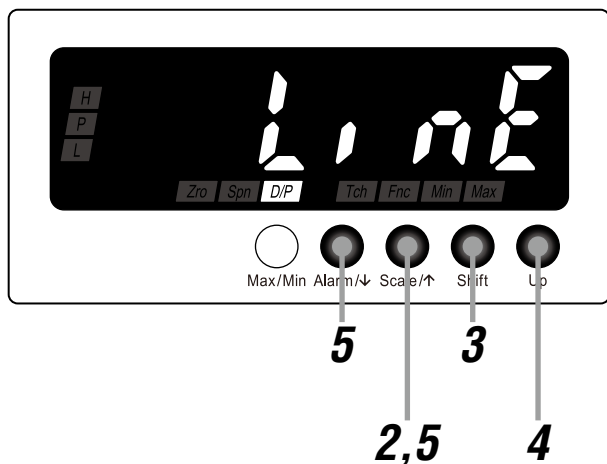

NOTE

- Procedures to change 'LINE' to 'SQRT' are described here.
- To change 'SQRT' to 'LINE', the procedures are same. Select 'LINE' in Step 4.

1 Confirm the wiring, and turn on the power.

- All the indications turn on for approximately 5 seconds and then the display moves on to Measuring Mode.

NOTE

Indication 'S.ERR' may blink, which shows the input out of the measurable range and does not show the unit failure.

- Immediately after power on (all indicators on)



- Measuring Mode



*1 Display depends on the settings and input.

2 Hold down Scale/↕ button for 3 seconds or more to move on to Scaling Setting Mode.

- The linearizer is indicated.
- 'D/P' indicator turns on.

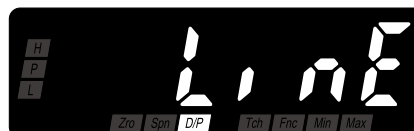

NOTE

Skip to Step 6 if the default value is acceptable.

3 Press Shift button to shift the display into the setting standby mode.

- The indication starts blinking, to which you can apply changes.

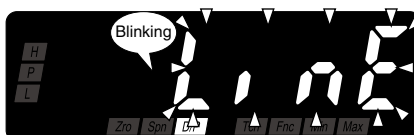

4 Press Up button to select 'SQRT'.

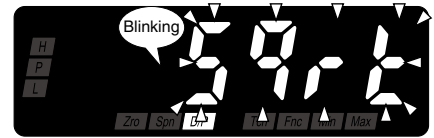

5 Press Alarm/↓ or Scale/↑ button to apply the new setting.

- And the next parameter setting is indicated.

NOTE

- Press Alarm/↓ button, and the input scaling ZERO will be indicated.
- Press Scale/↑ button, and the decimal point position will be indicated.

6 ■ TO GO ON TO SET THE INPUT SCALING ZERO,
Skip to Step 3 in "4.1 STEP 1. INPUT SCALING ZERO"

■ TO QUIT,

Hold down Alarm/↓ or Scale/↑ button for 3 seconds or more to return to Measuring Mode.

NOTE

■ IF THE FRONT BUTTONS ARE LEFT UNTOUCHED...

- The display goes back automatically to Measuring Mode without applying the last changes after the setting time out period (default: 60 sec.) in the setting standby mode (indication blinking in Step 3 and 4).
- The display goes back automatically to Measuring Mode after the setting time out period (default: 60 sec.) in one of the other modes.
- The setting time out is configurable. (Refer to 11. GOING BACK AUTOMATICALLY TO MEASURING MODE.)

■ TO ABORT A SETTING...

- Hold down Max/Min button for 3 seconds or more in the setting standby mode (indication blinking in Step 3 and 4) to return to Measuring Mode without applying the last changes.
- If you get lost in a setting mode, you can execute initialization. (Refer to 16.2 INITIALIZING SETTING VALUES.)

4. SETTING SCALING VALUES

■ INPUT SCALING

Input scaling means setting an input value within the setting range (4.00 – 20.00 mA DC).

The input scaling values include ZERO and SPAN.

- Input scaling ZERO is minimum value (0%) of input signal.
- Input scaling SPAN is maximum value (100%) of input signal.

e.g. Input signal 4 – 20 mA DC
Input scaling ZERO 4 mA
Input scaling SPAN 20 mA

IMPORTANT

- Set 'input scaling ZERO < input scaling SPAN'.
- Setting beyond the setting range is not available.
- Input scaling ZERO and input scaling SPAN can be adjusted by applying actual input signals. Refer to 14.1 TEACH CALIBRATION for details.

■ DISPLAY SCALING

Display scaling means setting a value to display actually.

The display scaling values include ZERO and SPAN. A decimal point can be set in any position.

- Display scaling ZERO is a display value for the input scaling ZERO.
- Display scaling SPAN is a display value for the input scaling SPAN.
- Decimal point position can be set in common for both display scaling ZERO and SPAN.

e.g. Display value 0.0 – 1000.0 m³
Display scaling ZERO 0.0 m³
Display scaling SPAN 1000.0 m³
Decimal point position 000.0 (1 decimal place)

IMPORTANT

Both normal scaling (display scaling ZERO < display scaling SPAN) and inverted scaling (display scaling ZERO > display scaling SPAN) can be set within the range of -19999 to 19999.

■ Normal Scaling

The display value increases when the input signal increases.

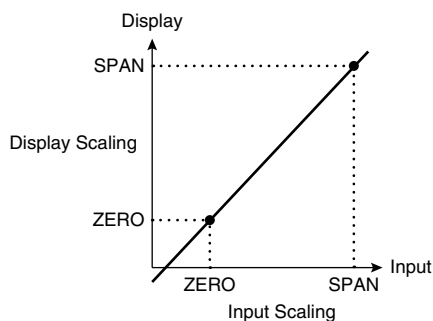

■ Inverted Scaling

The display value decreases when the input signal increases.

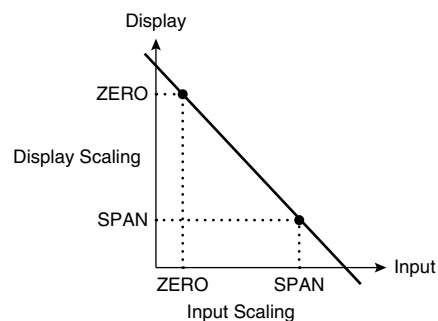

RELATION BETWEEN INPUT SCALING AND DISPLAY SCALING

The relation between input scaling and display scaling is as shown in the following figure.

e.g. To display 4 – 20 mA DC input as 0.0 – 1000.0 m³

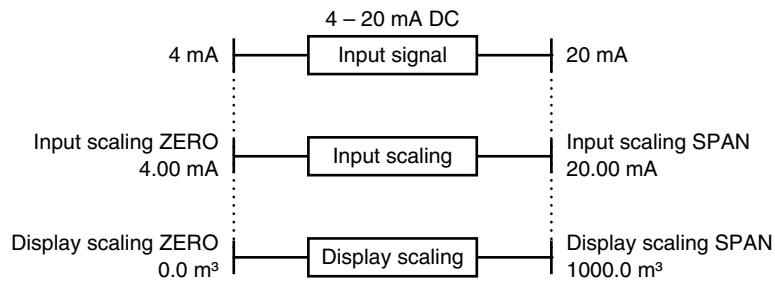

PROCEDURE TO SET SCALING VALUES

• Flow in setting scaling values

5-step settings are necessary to set scaling values.

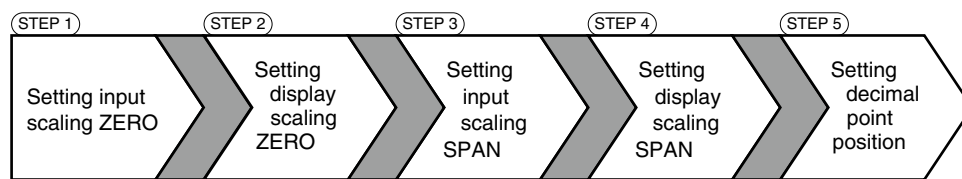

• Operating procedure to set scaling values

Following pages describe operating procedures in each step to set the input scaling to 4 – 20 mA DC, and the display scaling to 0.0 – 1000.0 m³ as an example.

4.1 STEP 1. INPUT SCALING ZERO

4.1.1 OPERATING PROCEDURE

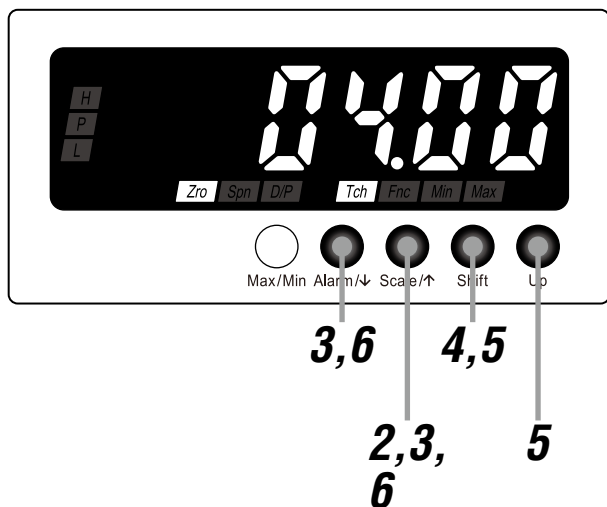

NOTE

The left figure shows a display example (default value 04.00). The display depends on the settings.

1 Confirm the wiring, and turn on the power.

- All the indications turn on for approximately 5 seconds and then the display moves on to Measuring Mode.

NOTE

Indication 'S.ERR' may blink, which shows the input out of the measurable range and does not show the unit failure.

- Immediately after power on (all indicators on)



- Measuring Mode



*1 Display depends on the settings and input.

2 Hold down Scale/↑ button for 3 seconds or more to move on to Scaling Setting Mode.

- The linearizer is indicated.
- 'D/P' indicator turns on.



NOTE

'LINE' or 'SQRT' is indicated depending on the setting.

3 Press Alarm/↓ or Scale/↑ button to go to the input scaling ZERO setting.

- The input scaling ZERO is indicated.
- 'Zro' and 'Tch' indicators turn on.

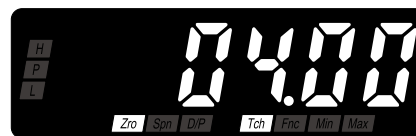

NOTE

Skip to Step 7 if the default value is acceptable.

4 Press Shift button to shift the display into the setting standby mode.

- The fifth digit starts blinking, to which you can apply changes.

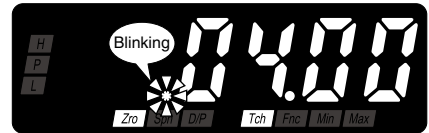

5 Press Shift and Up buttons to set to '04.00'.

- Press Shift button to go to the next digit and Up button to change the blinking value.

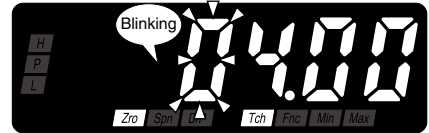

NOTE

- '04.00' is a display example. Set any value within the setting range.
- 'Min' and 'Max' indicators start blinking when the set value is within invalid range or is same as the input scaling SPAN. Return the setting within the valid range.

6 Press Alarm/↓ or Scale/↑ button to apply the new setting.

- And the next parameter setting is indicated.

NOTE

- Press Alarm/↓ button, and the display scaling ZERO will be indicated within the range of -19999 to 19999 depending on the setting.
- Press Scale/↑ button, and the linearizer 'LINE' or 'SQRT' will be indicated depending on the setting.

7 ■ TO GO ON TO SET THE DISPLAY SCALING ZERO,
Skip to Step 3 in "4.2 STEP 2. DISPLAY SCALING ZERO"

■ TO QUIT,

Hold down Alarm/↓ or Scale/↑ button for 3 seconds or more to return to Measuring Mode.

NOTE

■ INPUT SCALING SETTING

- Do not set 'input scaling ZERO \geq input scaling SPAN'.

■ IF THE FRONT BUTTONS ARE LEFT UNTOUCHED...

- The display goes back automatically to Measuring Mode without applying the last changes after the setting time out period (default: 60 sec.) in the setting standby mode (indication blinking in Step 4 and 5).
- The display goes back automatically to Measuring Mode after the setting time out period (default: 60 sec.) in one of the other modes.
- The setting time out is configurable. (Refer to 11. GOING BACK AUTOMATICALLY TO MEASURING MODE.)

■ TO ABORT A SETTING...

- Hold down Max/Min button for 3 seconds or more in the setting standby mode (indication blinking in Step 4 and 5) to return to Measuring Mode without applying the last changes.
- If you get lost in a setting mode, you can execute initialization. (Refer to 16.2 INITIALIZING SETTING VALUES.)

■ SHIFTING DIGITS

- Each time pressing Shift button, the blinking digit moves to the right.

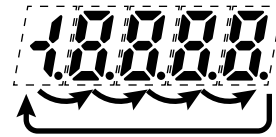

■ SETTING A NUMERICAL VALUE

- Each time pressing Up button, the numeral is incremented by 1.



4.2 STEP 2. DISPLAY SCALING ZERO

4.2.1 OPERATING PROCEDURE

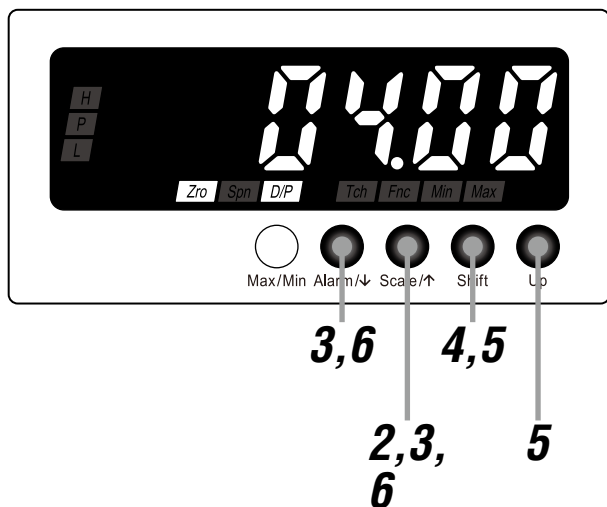

NOTE

The left figure shows a display example (default value 04.00). The display depends on the settings.

1 Confirm the wiring, and turn on the power.

- All the indications turn on for approximately 5 seconds and then the display moves on to Measuring Mode.

NOTE

Indication 'S.ERR' may blink, which shows the input out of the measurable range and does not show the unit failure.

- Immediately after power on (all indicators on)



- Measuring Mode



*1 Display depends on the settings and input.

2 Hold down Scale/↑ button for 3 seconds or more to move on to Scaling Setting Mode.

- The linearizer is indicated.
- 'D/P' indicator turns on.



NOTE

'LINE' or 'SQRT' is indicated depending on the setting.

3 Press Alarm/↓ or Scale/↑ button to go to the display scaling ZERO setting.

- The display scaling ZERO is indicated.
- 'Zro' and 'D/P' indicators turn on.



NOTE

Skip to Step 7 if the default value is acceptable.

4 Press Shift button to shift the display into the setting standby mode.

- The fifth digit starts blinking, to which you can apply changes.



5 Press Shift and Up buttons to set to '00.00'.

- Press Shift button to go to the next digit and Up button to change the blinking value.

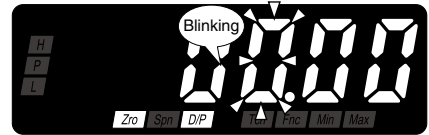

NOTE

- '00.00' is a display example. Set any value within the range of -19999 to 19999.
- The decimal point position depends on the decimal point position setting. Disregard the decimal point here.
- 'Min' and 'Max' indicators start blinking when the set value is same as the display scaling SPAN. Return the setting within the valid range.
- The negative sign (-) must be set to the leftmost digit. For example, set '-04.00' instead of '-4.00'.

6 Press Alarm/↓ or Scale/↑ button to apply the new setting.

- And the next parameter setting is indicated.

NOTE

- Press Alarm/↓ button, and the input scaling SPAN will be indicated.
- Press Scale/↑ button, and the input scaling ZERO will be indicated.

7 ■ TO GO ON TO SET THE INPUT SCALING SPAN,
Skip to Step 3 in "4.3 STEP 3. INPUT SCALING SPAN"

■ TO QUIT,

Hold down Alarm/↓ or Scale/↑ button for 3 seconds or more to return to Measuring Mode.

NOTE

■ IF THE FRONT BUTTONS ARE LEFT UNTOUCHED...

- The display goes back automatically to Measuring Mode without applying the last changes after the setting time out period (default: 60 sec.) in the setting standby mode (indication blinking in Step 4 and 5).
- The display goes back automatically to Measuring Mode after the setting time out period (default: 60 sec.) in one of the other modes.
- The setting time out is configurable. (Refer to 11. GOING BACK AUTOMATICALLY TO MEASURING MODE.)

■ TO ABORT A SETTING...

- Hold down Max/Min button for 3 seconds or more in the setting standby mode (indication blinking in Step 4 and 5) to return to Measuring Mode without applying the last changes.
- If you get lost in a setting mode, you can execute initialization. (Refer to 16.2 INITIALIZING SETTING VALUES.)

■ SHIFTING DIGITS

- Each time pressing Shift button, the blinking digit moves to the right.

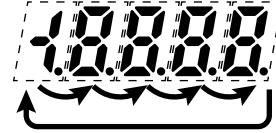

■ SETTING A NUMERICAL VALUE

- Each time pressing Up button, the numeral is incremented by 1.



4.3 STEP 3. INPUT SCALING SPAN

4.3.1 OPERATING PROCEDURE

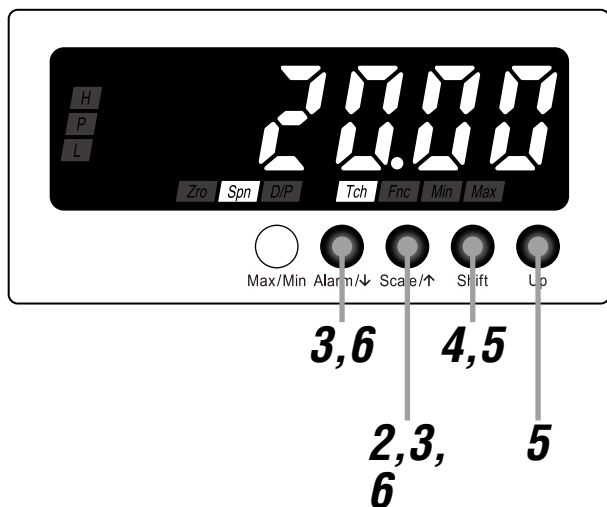

NOTE

The left figure shows a display example (default value 20.00). The display depends on the settings.

1 Confirm the wiring, and turn on the power.

- All the indications turn on for approximately 5 seconds and then the display moves on to Measuring Mode.

NOTE

Indication 'S.ERR' may blink, which shows the input out of the measurable range and does not show the unit failure.

- Immediately after power on (all indicators on)



- Measuring Mode



*1 Display depends on the settings and input.

2 Hold down Scale/↑ button for 3 seconds or more to move on to Scaling Setting Mode.

- The linearizer is indicated.
- 'D/P' indicator turns on.



NOTE

'LINE' or 'SQRT' is indicated depending on the setting.

3 Press Alarm/↓ or Scale/↑ button to go to the input scaling SPAN setting.

- The input scaling SPAN is indicated.
- 'Spn' and 'Tch' indicators turn on.



NOTE

Skip to Step 7 if the default value is acceptable.

4 Press Shift button to shift the display into the setting standby mode.

- The fifth digit starts blinking, to which you can apply changes.



5 Press Shift and Up buttons to set to '20.00'.

- Press Shift button to go to the next digit and Up button to change the blinking value.

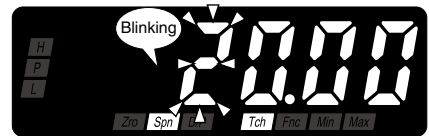

NOTE

- '20.00' is a display example. Set any value within the setting range.
- 'Min' and 'Max' indicators start blinking when the set value is within invalid range or is same as the input scaling ZERO. Return the setting within the valid range.

6 Press Alarm/↓ or Scale/↑ button to apply the new setting.

- And the next parameter setting is indicated.

NOTE

- Press Alarm/↓ button, and the display scaling SPAN will be indicated within the range of -19999 to 19999 depending on the setting.
- Press Scale/↑ button, and the display scaling ZERO will be indicated within the range of -19999 to 19999 depending on the setting.

7 ■ TO GO ON TO SET THE DISPLAY SCALING SPAN,
Skip to Step 3 in "4.4 STEP 4. DISPLAY SCALING SPAN"

■ TO QUIT,

Hold down Alarm/↓ or Scale/↑ button for 3 seconds or more to return to Measuring Mode.

NOTE

■ INPUT SCALING SETTING

- Do not set 'input scaling ZERO \geq input scaling SPAN'.

■ IF THE FRONT BUTTONS ARE LEFT UNTOUCHED...

- The display goes back automatically to Measuring Mode without applying the last changes after the setting time out period (default: 60 sec.) in the setting standby mode (indication blinking in Step 4 and 5).
- The display goes back automatically to Measuring Mode after the setting time out period (default: 60 sec.) in one of the other modes.
- The setting time out is configurable. (Refer to 11. GOING BACK AUTOMATICALLY TO MEASURING MODE.)

■ TO ABORT A SETTING...

- Hold down Max/Min button for 3 seconds or more in the setting standby mode (indication blinking in Step 4 and 5) to return to Measuring Mode without applying the last changes.
- If you get lost in a setting mode, you can execute initialization. (Refer to 16.2 INITIALIZING SETTING VALUES.)

■ SHIFTING DIGITS

- Each time pressing Shift button, the blinking digit moves to the right.

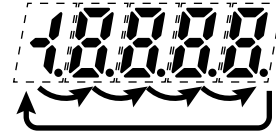

■ SETTING A NUMERICAL VALUE

- Each time pressing Up button, the numeral is incremented by 1.



4.4 STEP 4. DISPLAY SCALING SPAN

4.4.1 OPERATING PROCEDURE

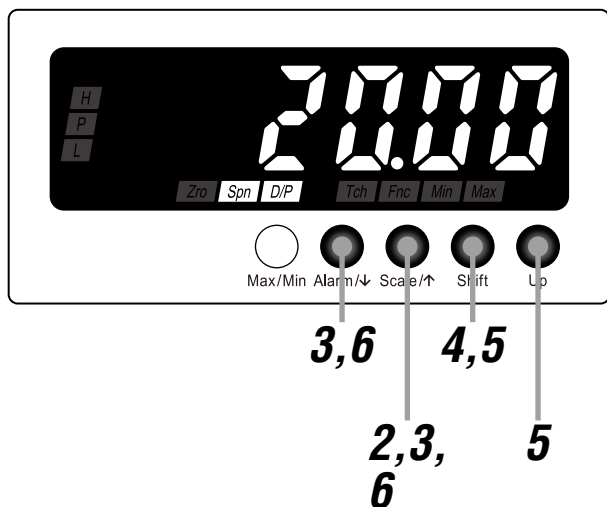

NOTE

The left figure shows a display example (default value 20.00). The display depends on the settings.

1 Confirm the wiring, and turn on the power.

- All the indications turn on for approximately 5 seconds and then the display moves on to Measuring Mode.

NOTE

Indication 'S.ERR' may blink, which shows the input out of the measurable range and does not show the unit failure.

- Immediately after power on (all indicators on)



- Measuring Mode



*1 Display depends on the settings and input.

2 Hold down Scale/↑ button for 3 seconds or more to move on to Scaling Setting Mode.

- The linearizer is indicated.
- 'D/P' indicator turns on.



NOTE

'LINE' or 'SQRT' is indicated depending on the setting.

3 Press Alarm/↓ or Scale/↑ button to go to the display scaling SPAN setting.

- The display scaling SPAN is indicated.
- 'Spn' and 'D/P' indicators turn on.



NOTE

Skip to Step 7 if the default value is acceptable.

4 Press Shift button to shift the display into the setting standby mode.

- The fifth digit starts blinking, to which you can apply changes.



5 Press Shift and Up buttons to set to '100.00'.

- Press Shift button to go to the next digit and Up button to change the blinking value.

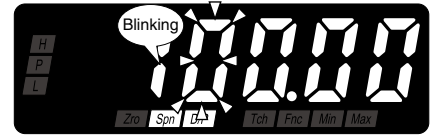

NOTE

- '100.00' is a display example. Set any value within the range of -19999 to 19999.
- The decimal point position depends on the decimal point position setting. Disregard the decimal point here.
- 'Min' and 'Max' indicators start blinking when the set value is same as the display scaling ZERO. Return the setting within the valid range.
- The negative sign (-) must be set to the leftmost digit. For example, set '-04.00' instead of '-4.00'

6 Press Alarm/↓ or Scale/↑ button to apply the new setting.

- And the next parameter setting is indicated.

NOTE

- Press Alarm/↓ button, and the decimal point position will be indicated.
- Press Scale/↑ button, and the input scaling SPAN will be indicated.

7 ■ TO GO ON TO SET THE DECIMAL POINT POSITION,
Skip to Step 3 in "4.5 STEP 5. DECIMAL POINT POSITION".

■ TO QUIT,

Hold down Alarm/↓ or Scale/↑ button for 3 seconds or more to return to Measuring Mode.

NOTE

■ IF THE FRONT BUTTONS ARE LEFT UNTOUCHED...

- The display goes back automatically to Measuring Mode without applying the last changes after the setting time out period (default: 60 sec.) in the setting standby mode (indication blinking in Step 4 and 5).
- The display goes back automatically to Measuring Mode after the setting time out period (default: 60 sec.) in one of the other modes.
- The setting time out is configurable. (Refer to 11. GOING BACK AUTOMATICALLY TO MEASURING MODE.)

■ TO ABORT A SETTING...

- Hold down Max/Min button for 3 seconds or more in the setting standby mode (indication blinking in Step 4 and 5) to return to Measuring Mode without applying the last changes.
- If you get lost in a setting mode, you can execute initialization. (Refer to 16.2 INITIALIZING SETTING VALUES.)

■ SHIFTING DIGITS

- Each time pressing Shift button, the blinking digit moves to the right.

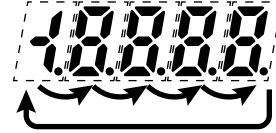

■ SETTING A NUMERICAL VALUE

- Each time pressing Up button, the numeral is incremented by 1.



4.5 STEP 5. DECIMAL POINT POSITION

4.5.1 OPERATING PROCEDURE

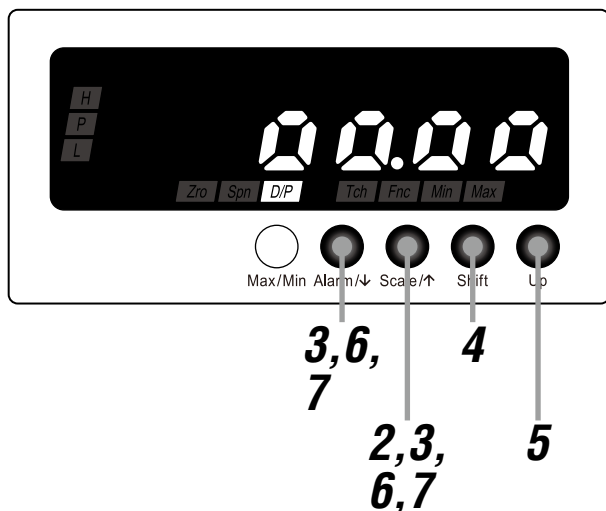

NOTE

The left figure shows a display example (default value 00.00). The display depends on the settings.

1 Confirm the wiring, and turn on the power.

- All the indications turn on for approximately 5 seconds and then the display moves on to Measuring Mode.

- Immediately after power on (all indicators on)



NOTE

Indication 'S.ERR' may blink, which shows the input out of the measurable range and does not show the unit failure.

- Measuring Mode



*1 Display depends on the settings and input.

2 Hold down Scale/↑ button for 3 seconds or more to move on to Scaling Setting Mode.

- The linearizer is indicated.
- 'D/P' indicator turns on.



NOTE

'LINE' or 'SQRT' is indicated depending on the setting.

3 Press Alarm/↓ or Scale/↑ button to go to the decimal point position setting.

- The decimal point position is indicated.
- 'D/P' indicator turns on.



NOTE

Skip to Step 7 if the default value is acceptable.

4 Press Shift button to shift the display into the setting standby mode.

- The indication starts blinking, to which you can apply changes.

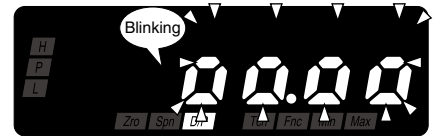

5 Press Up button to select the decimal point position.

- Select 1 decimal place (10^{-1}).
- Press Up button to move the decimal point.

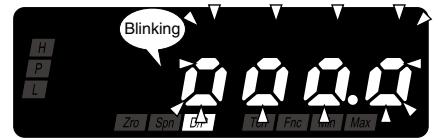

NOTE

The right figure shows a display example. Select one among “no decimal point,” and “1 decimal place” to “4 decimal places”

6 Press Alarm/↓ or Scale/↑ button to apply the new setting.

- And the next parameter setting is indicated.

NOTE

- Press Alarm/↓ button, and the linearizer ‘LINE’ or ‘SQRT’ will be indicated depending on the setting.
- Press Scale/↑ button, and the display scaling SPAN will be indicated within the range of -19999 to 19999 depending on the setting.

7 Hold down Alarm/↓ or Scale/↑ button for 3 seconds or more to return to Measuring Mode.

NOTE

■ IF THE FRONT BUTTONS ARE LEFT UNTOUCHED...

- The display goes back automatically to Measuring Mode without applying the last changes after the setting time out period (default: 60 sec.) in the setting standby mode (indication blinking in Step 4 and 5).
- The display goes back automatically to Measuring Mode after the setting time out period (default: 60 sec.) in one of the other modes.
- The setting time out is configurable. (Refer to 11. GOING BACK AUTOMATICALLY TO MEASURING MODE.)

■ TO ABORT A SETTING...

- Hold down Max/Min button for 3 seconds or more in the setting standby mode (indication blinking in Step 4 and 5) to return to Measuring Mode without applying the last changes.
- If you get lost in a setting mode, you can execute initialization. (Refer to 16.2 INITIALIZING SETTING VALUES.)

■ MOVING THE DECIMAL POINT

- Pressing Up button moves the decimal point one place to the left.

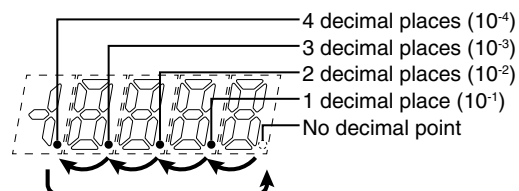

■ DECIMAL POINT POSITION

- “No decimal point” to “4 decimal places” can be selected in the decimal point position setting.

SETTING VALUE	FUNCTION	SETTING VALUE	FUNCTION
□□□□	No decimal point	□□□□	3 decimal places (10^{-3})
□□□□	1 decimal place (10^{-1})	□□□□	4 decimal places (10^{-4})
□□□□	2 decimal places (10^{-2})		

5. OPERATION

Make sure that $0.0 - 1000.0 \text{ m}^3$ is correctly indicated with square root extraction according to the input $4 - 20 \text{ mA DC}$ provided.

IMPORTANT

Before operating, make sure that the wiring is correct, the input and the power supply are within the specification range.

- 1 Provide 4 mA input (0%) and make sure that 0.0 m^3 (0%) is indicated.



*1 Display depends on the settings and input.

NOTE

■ WHEN THE FOLLOWING IS INDICATED...

- When 'S.ERR' is indicated, the input is not applied correctly. Check the input wiring, equipment and signal. When 'Min' indicator blinks, the input signal is under the specification voltage/current. And when 'Max' indicator blinks, the input is over the specification voltage/current.
- When the indication is shifted with 'Zro' and 'Fnc' indicators on, the Forced Zero is being executed. Cancel the Forced Zero. (Refer to 13.2 FORCING THE PRESENT DISPLAY VALUE TO ZERO.)

■ ALARM INDICATORS

- The status of the alarm indicators depend on the alarm setpoints. The above display examples show 'P' indicator on.

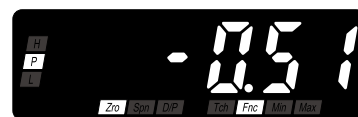
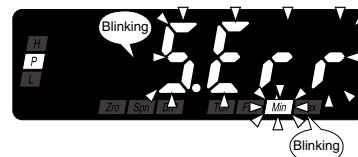

- 2 Provide 8 mA input (25%) and make sure that 500.0 m^3 (50%) is indicated.



- 3 Provide 20 mA input (100%) and make sure that 1000.0 m^3 (100%) is indicated.



NOTE

- When the indication is shifted with the function indicators off, perform Teach Calibration. (Refer to 14.1 TEACH CALIBRATION.)
- When the linearizer is set to "linear", make sure that 250.0 m^3 (25%) is indicated in Step 2.

6. PARAMETER CONFIGURATION

■ MODE

Parameters can be grouped in several modes.
The 47NLDY has modes as shown in the following table.

MODE	FUNCTION	MEASUREMENT
Measuring	Normal measurement state where the unit takes in input and provides alarms. Present value, MAX and MIN values, alarm setpoints can be indicated in Measuring Mode. Also Forced Zero can be executed and canceled in this mode. When the power is supplied, the unit operates in Measuring Mode.	Measuring
Scaling Setting	Basic settings such like linearizer, input scaling and display scaling, and Teach Calibration can be performed.	Measuring stopped
Alarm Setting	Alarm setpoints, trip action, deadband, trip delay and alarm output logic can be set.	
Advanced Setting	Moving average, low-end cutout and brightness can be set. Also the firmware version can be confirmed.	
Lockout Setting	Settings to prevent inadvertent button operation can be performed. Mode transition and set values can be locked.	

■ MODE TRANSITION

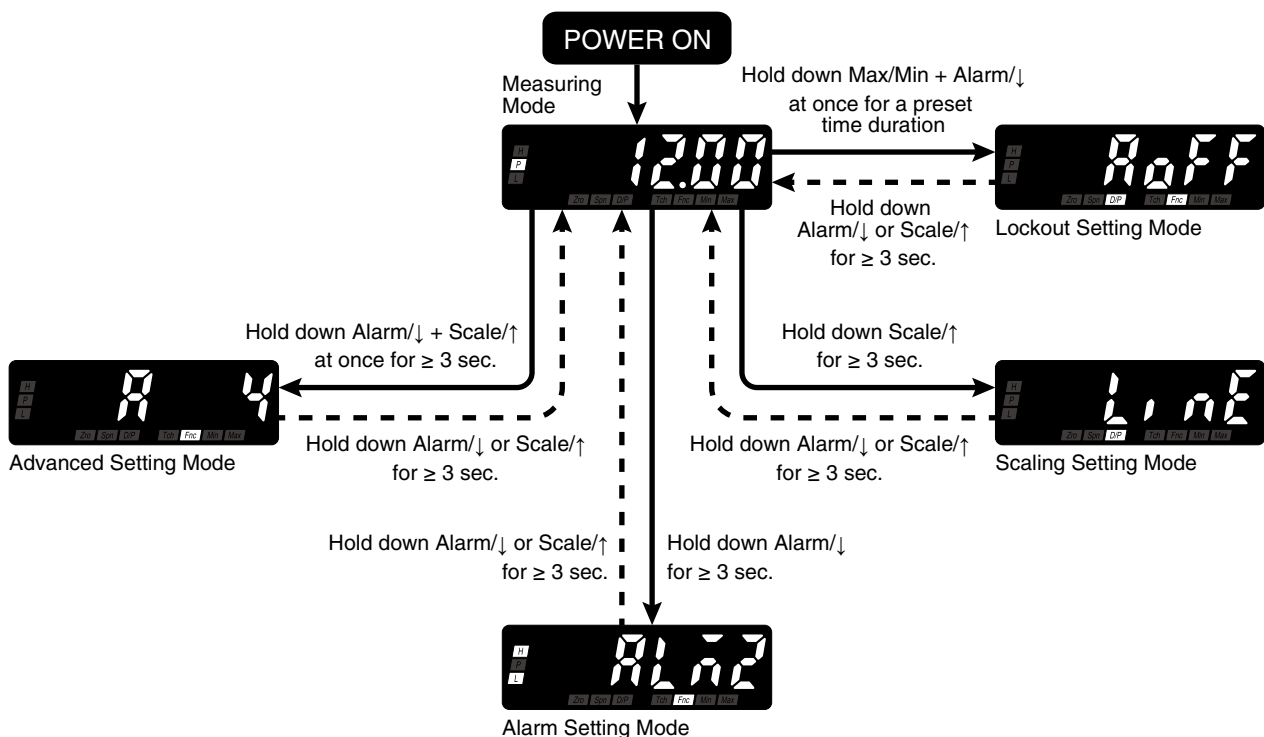

■ TRANSITION FROM MEASURING MODE TO EACH MODE

To Scaling Setting Mode	Hold down Scale/↑ button for 3 seconds or more.
To Alarm Setting Mode	Hold down Alarm/↓ button for 3 seconds or more.
To Advanced Setting Mode	Hold down Alarm/↓ + Scale/↑ buttons at once for 3 seconds or more.
To Lockout Setting Mode	Hold down Max/Min + Alarm/↓ buttons at once for a preset time duration.

■ TRANSITION FROM EACH MODE TO MEASURING MODE

Hold down Alarm/↓ or Scale/↑ button for 3 seconds or more to return to Measuring Mode.

SHIFTING THROUGH SETTING PARAMETERS

(1) Parameter shifting in Scaling Setting Mode

In Scaling Setting Mode, pressing Alarm/↓ button shifts one parameter to the next (clockwise in the following figure). Pressing Scale/↑ button shifts one to the previous (counterclockwise).

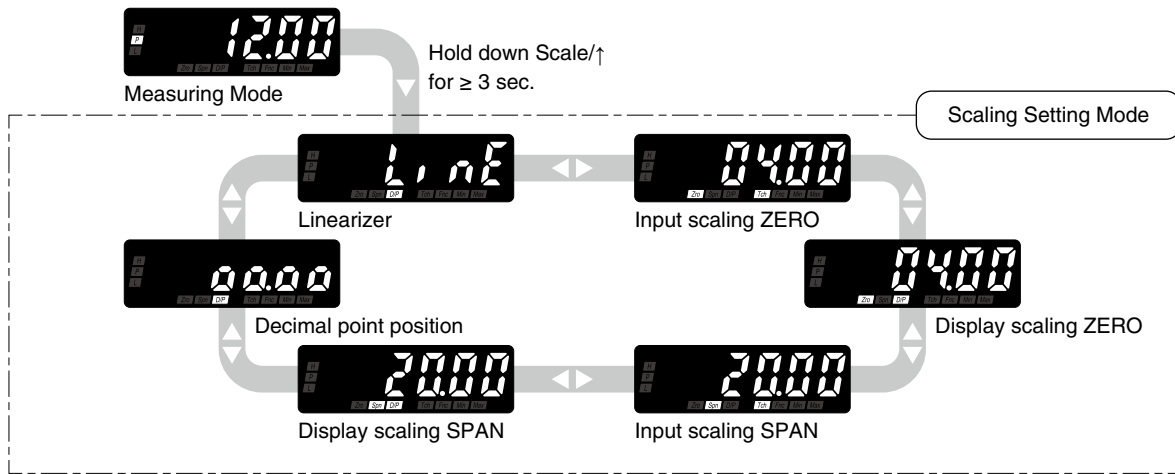

NOTE

- The display depends on the settings and input. The above displays show default values.
- Hold down Alarm/↓ or Scale/↑ button for 3 seconds or more to return to Measuring Mode from each parameter.

(2) Parameter shifting in Alarm Setting Mode

In Alarm Setting Mode, pressing Alarm/↓ button shifts one parameter to the next (clockwise in the following figure). Pressing Scale/↑ button shifts one to the previous (counterclockwise).

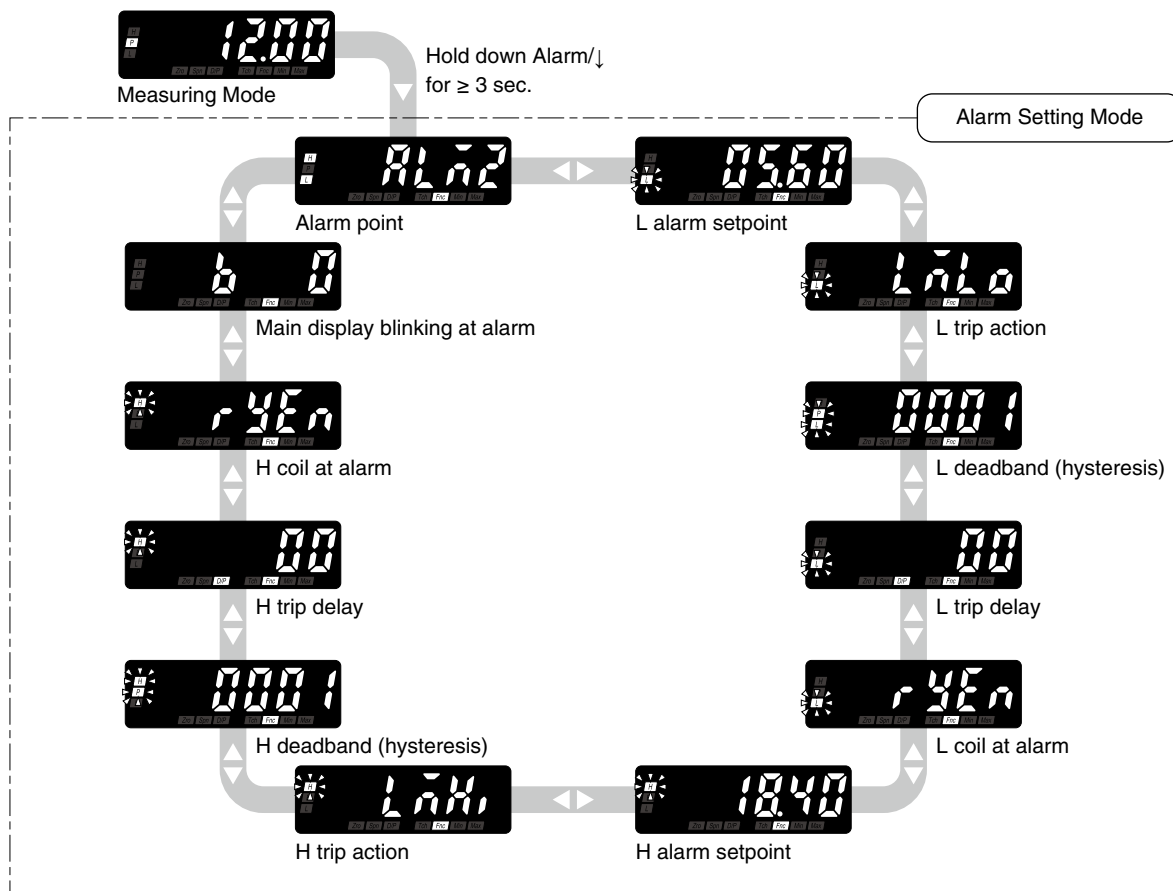

NOTE

- The display depends on the settings and input. The above displays show default values.
- Alarm Setting Mode is locked when “No alarm” is selected for the alarm point parameter.
- Hold down Alarm/↓ or Scale/↑ button for 3 seconds or more to return to Measuring Mode from each parameter.

(3) Parameter shifting in Advanced Setting Mode

In Advanced Setting Mode, pressing Alarm/↓ button shifts one parameter to the next (clockwise in the following figure). Pressing Scale/↑ button shifts one to the previous (counterclockwise).

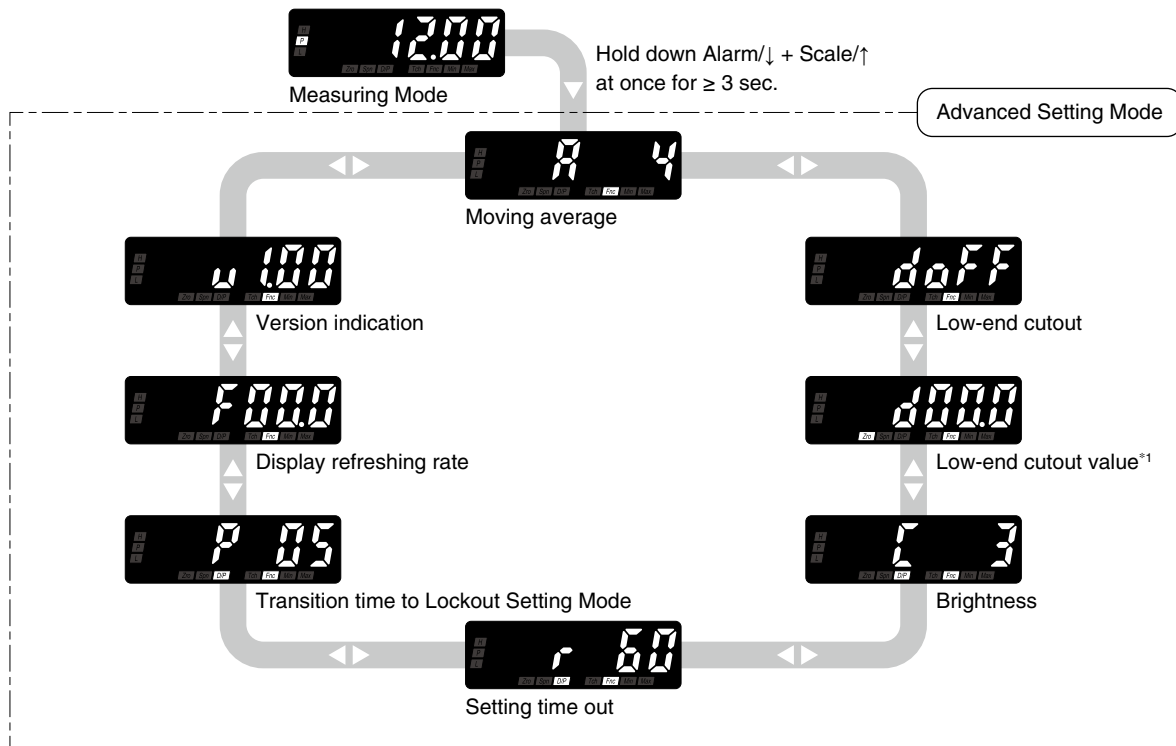

*1 With the low-end cutout set to OFF, the low-end cutout value setting is locked.

NOTE

- The display depends on the settings and input. The above displays show default values.
- Hold down Alarm/↓ or Scale/↑ button for 3 seconds or more to return to Measuring Mode from each parameter.

(4) Parameter shifting in Lockout Setting Mode

In Lockout Setting Mode, pressing Alarm/↓ button shifts one parameter to the next (clockwise in the following figure). Pressing Scale/↑ button shifts one to the previous (counterclockwise).

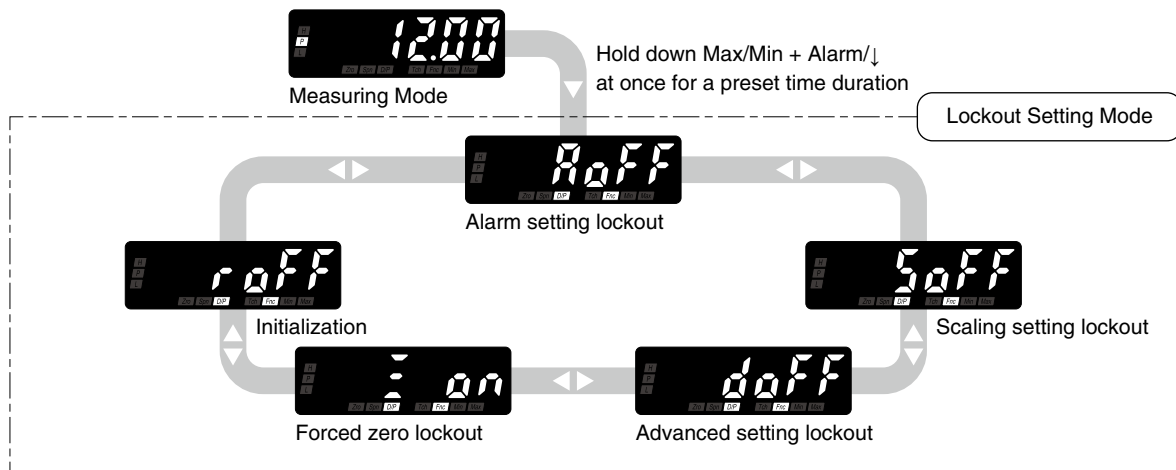

NOTE

- The display depends on the settings and input. The above displays show default values.
- Hold down Alarm/↓ or Scale/↑ button for 3 seconds or more to return to Measuring Mode from each parameter.

7. SETTING ALARM OUTPUT

The unit compares the present value with the alarm setpoints, and provides an alarm output (photo MOSFET relay). You can configure parameters as alarm conditions as shown in Tables 1 and 2. Figures 1 to 5 show alarm examples using each parameter.

■ TABLE 1: ALARM OUTPUT PARAMETERS

PARAMETER	FUNCTION
Alarm point	Dual alarm or no alarm
Alarm setpoint	Setpoint value within the range of -19999 to 19999 for the display value (value after square root extraction with the linearizer set to "square root extraction").
Trip action	High or low trip Configuring typical L/H trip setting (Figure 1) or all trip points to high or low setting (Figure 2) is available. 'P' indicator turns on when none of the other alarms is tripped.
Deadband (hysteresis)	Once a high (low) trip alarm is ON, the alarm stays ON until the data becomes lower (higher) than the dead band value from the setpoint, which prevents the alarm output from chattering when the display value fluctuates slightly near the setpoint (Figure 3). Deadband works in the direction of increasing the display value for low trip and in the direction of decreasing it for high.
Trip delay	Alarm output is provided when the display value exceeds the setpoint and stayed for the specified time duration, which prevents the alarm output from being provided by a sudden change such like external disturbance and starting current (Figure 4).
Coil at alarm	Alarm output logic, coil energized or de-energized at alarm (Figure 5).
Main display blinking at alarm	Main display blinking interval at alarm can be selected among 5 intervals (Table 2).

■ TABLE 2: SETTING VALUES

PARAMETER	DISPLAY	FUNCTION	DEFAULT VALUE
Alarm point	<input type="text" value="RLn2"/>	Dual alarm	<input type="text" value="RLn2"/>
	<input type="text" value="RLn0"/>	No alarm	
Alarm setpoint	<input type="text" value="19999"/> to <input type="text" value="19999"/>	-19999 to 19999	L alarm setpoint: <input type="text" value="0560"/> H alarm setpoint: <input type="text" value="1840"/>
Trip action	<input type="text" value="LnLo"/>	Lo trip	L trip action: <input type="text" value="LnLo"/>
	<input type="text" value="LnHi"/>	Hi trip	H trip action: <input type="text" value="LnHi"/>
Deadband (hysteresis)	<input type="text" value="0000"/> to <input type="text" value="9999"/>	0000 – 9999	<input type="text" value="0000"/>
Trip delay	<input type="text" value="00"/> to <input type="text" value="99"/>	0 – 99 seconds	<input type="text" value="00"/>
Coil at alarm	<input type="text" value="rYEn"/>	Coil energized at alarm	<input type="text" value="rYEn"/>
	<input type="text" value="rYd0"/>	Coil de-energized at alarm	
Main display blinking at alarm	<input type="text" value="b 0"/>	No blinking	<input type="text" value="b 0"/>
	<input type="text" value="b 1"/>	Blinking in 1.0 second intervals	
	<input type="text" value="b 2"/>	Blinking in 0.5 second intervals	
	<input type="text" value="b 3"/>	Blinking in 0.2 second intervals	
	<input type="text" value="b 4"/>	Blinking in 0.1 second intervals	

Figure 1: Typical L/H trip setting

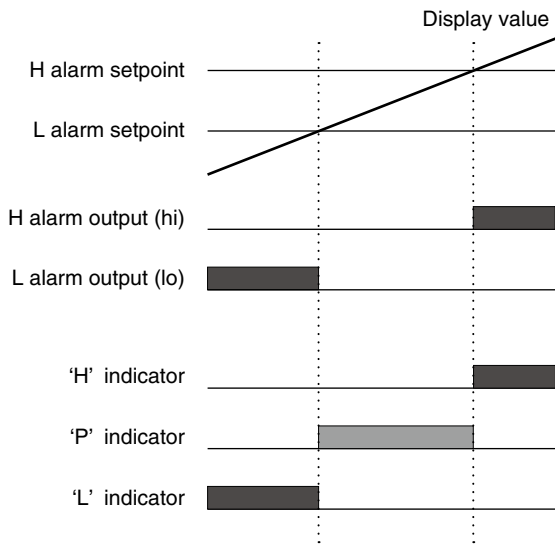
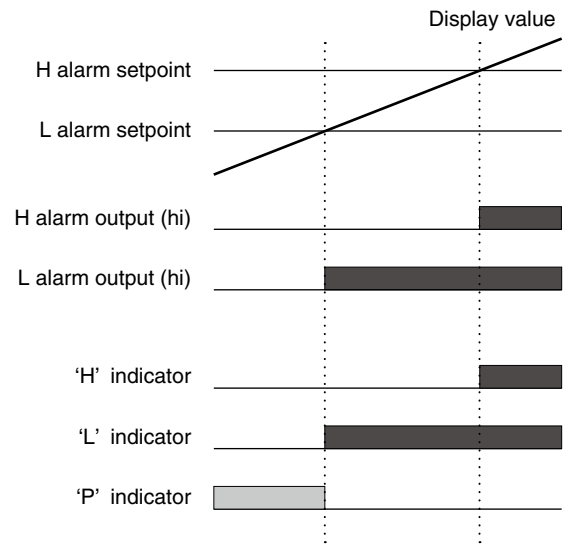

Figure 2: All trip points set to high setting



Low or high trip action can be set for each alarm output. 'L' and 'H' indicators are fixed for each alarm output. Therefore, even in case setting L alarm output to high trip action, for example, 'L' indicator turns on at alarm.

Figure 3: Deadband (hysteresis)

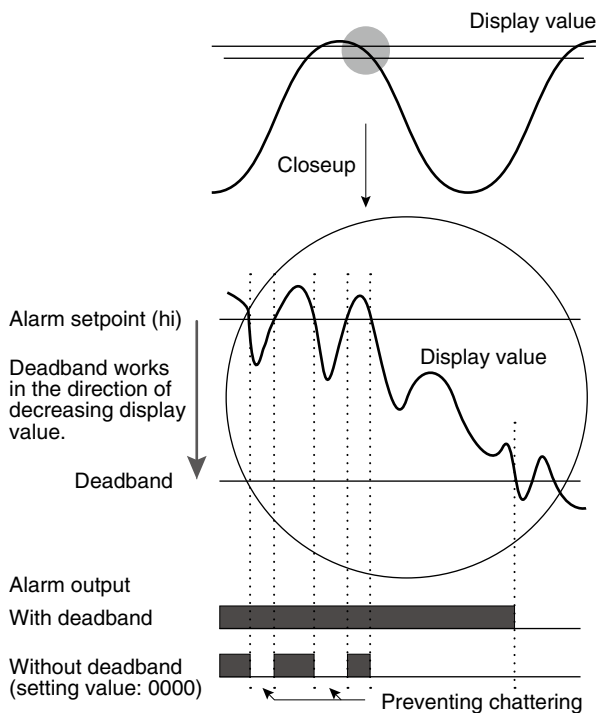
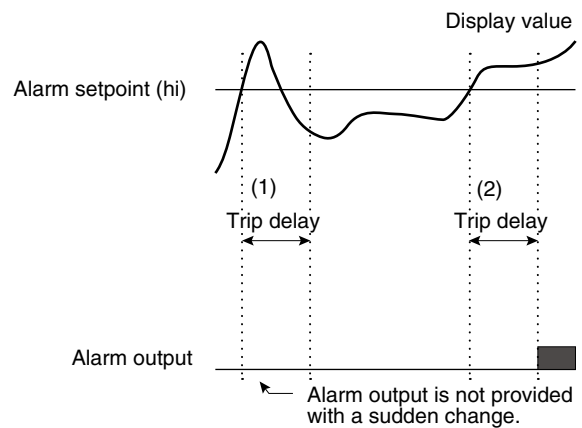
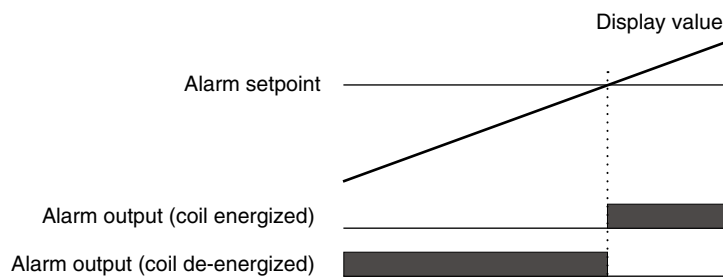

Figure 4: Trip delay



- (1) The display value once exceeds the alarm setpoint but becomes below it during trip delay time period. Therefore alarm output is not provided.
- (2) The display value exceeds the setpoint and stays over the trip delay time period. Therefore alarm output is provided.

Figure 5: Coil at alarm



In order to stop operation of an equipment when the display value exceeds the setpoint, for instance, set reversal output logic, "coil de-energized".

IMPORTANT

- When indication 'S.ERR' and 'Min' indicator blink, all the low alarm outputs are provided. When indication 'S.ERR' and 'Max' indicator blink, all the high alarm outputs are provided.
 - When indication '-19999' blinks, all the low alarm outputs are provided. When '19999' blinks, all the high alarm outputs are provided.
 - When indication 'O.L.' blinks, all the high alarm outputs are provided.
-

7.1 ALARM POINT

The alarm point, no alarm 'ALM0' or dual alarm 'ALM2', can be selected.

7.1.1 OPERATING PROCEDURE

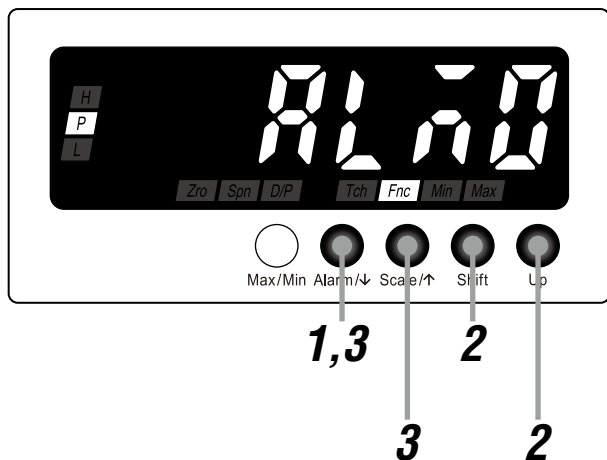

NOTE

- Procedures to change 'ALM0' to 'ALM2' are described here.
- To change 'ALM2' to 'ALM0', the procedures are same. Select 'ALM0' in Step 2.

1 Hold down Alarm/↓ button for 3 seconds or more to move on to Alarm Setting Mode.

- The alarm point is indicated.
- 'P' and 'Fnc' indicators turn on.

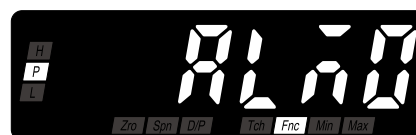

2 Press Shift or Up button to select 'ALM2'.

- 'H' and 'L' indicators now turn on.

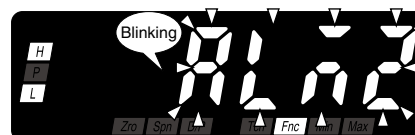

3 Press Alarm/↓ or Scale/↑ button to apply the new setting.

- And the next parameter setting is indicated.

NOTE

- Press Alarm/↓ button, and the L alarm setpoint will be indicated within the range of -19999 to 19999 depending on the setting.
- Press Scale/↑ button, and the main display blinking at alarm 'B 0', 'B 1', 'B 2', 'B 3' or 'B 4' will be indicated depending on the setting.
- When "No alarm" is selected for the alarm point parameter, Alarm Setting Mode is locked.

4 ■ TO SET THE NEXT PARAMETER, Skip to Step 2 in "7.2 ALARM SETPOINT"

■ TO QUIT,

Hold down Alarm/↓ or Scale/↑ button for 3 seconds or more to return to Measuring Mode.

7.2 ALARM SETPOINT

Alarm setpoints can be set within the range of -19999 to 19999. However the alarm is not provided in setting the setpoint beyond the conformance range. Set the setpoints within the valid range.

7.2.1 ALARM SETPOINT DEFAULT VALUE

PARAMETER	DEFAULT VALUE
L alarm setpoint	0560
H alarm setpoint	1840

7.2.2 OPERATING PROCEDURE

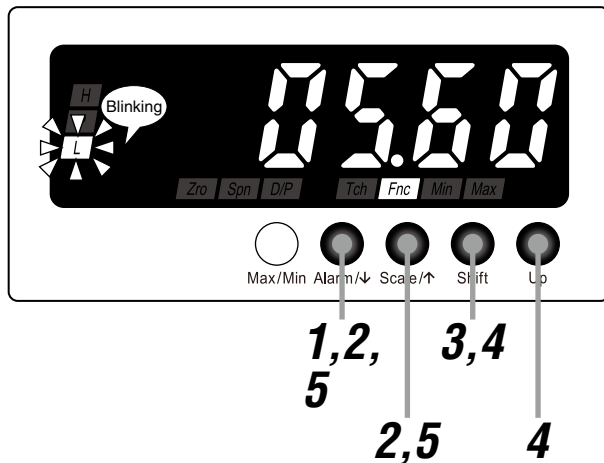

NOTE

The following figures are display examples. The displays depend on the settings.

1 Hold down Alarm/↓ button for 3 seconds or more to move on to Alarm Setting Mode.

- The alarm point is indicated.
- 'H', 'L' and 'Fnc' indicators turn on.



2 Press Alarm/↓ or Scale/↑ button to go to the L (H) alarm set-point setting.

- The L (H) alarm setpoint is indicated.
- 'L' ('H') indicator blinks and 'Fnc' indicator turns on.



■ Display in setting H alarm setpoint

NOTE

The setpoint is indicated within the range of -19999 to 19999 depending on the setting.

3 Press Shift button to shift the display into the setting standby mode.

- The fifth digit starts blinking, to which you can apply changes.



4 Press Shift and Up buttons to set the L (H) alarm setpoint.

- Set within the range of -19999 to 19999.

IMPORTANT

Specify '----' to disable the alarm output.

NOTE

Set the alarm setpoint with the decimal point position set in the decimal point position setting.

5 Press Alarm/↓ or Scale/↑ button to apply the new setting.

- And the next parameter setting is indicated.

NOTE

- Press Alarm/↓ button, and the L (H) trip action 'LMLO' or 'LMHI' will be indicated depending on the setting.
- Press Scale/↑ button, and the alarm point 'ALM2' (or L coil at alarm 'RYEN' or 'RYDN') will be indicated.

6 ■ TO GO ON TO SET ANOTHER ALARM SETPOINT,
Repeat operation from Step 2.

■ TO SET THE NEXT PARAMETER,
Skip to Step 2 in "7.3 TRIP ACTION (LO/HI):"

■ TO QUIT,
Hold down Alarm/↓ or Scale/↑ button for 3 seconds or more to return to Measuring Mode.

7.3 TRIP ACTION (LO/HI)

The trip action low 'LMLO' or high 'LMHI' can be selected. Configuring typical L/H trip setting or all trip points to high or low setting is available. The default values are "low trip" for the L trip action and "high trip" for the H.

7.3.1 OPERATING PROCEDURE

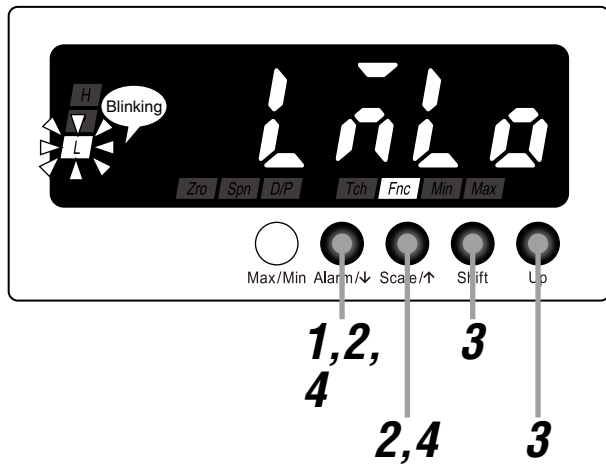

NOTE

- Procedures to change 'LMLO' to 'LMHI' are described here.
- To change 'LMHI' to 'LMLO', the procedures are same. Select 'LMLO' in Step 3.

1 Hold down Alarm/↓ button for 3 seconds or more to move on to Alarm Setting Mode.

- The alarm point is indicated.
- 'H', 'L' and 'Fnc' indicators turn on.



2 Press Alarm/↓ or Scale/↑ button to go to the L (H) trip action setting.

- 'LMLO' is indicated.
- 'L' ('H') indicator blinks and 'Fnc' indicator turns on.



■ Display in setting H trip action

3 Press Shift or Up button to select 'LMHI'.

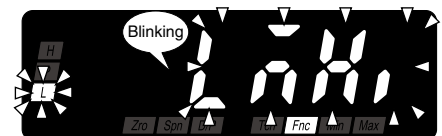

.....

4 Press Alarm/↓ or Scale/↑ button to apply the new setting.

- And the next parameter setting is indicated.

NOTE

- Press Alarm/↓ button, and the L (H) deadband will be indicated within the range of 0000 to 9999 depending on the setting.
 - Press Scale/↑ button, and the L (H) alarm setpoint will be indicated within the range of -19999 to 19999 depending on the setting.
-

.....

5 ■ TO GO ON TO SET ANOTHER TRIP ACTION,

Repeat operation from Step 2.

■ TO SET THE NEXT PARAMETER,

Skip to Step 2 in “7.4 DEADBAND”

■ TO QUIT,

Hold down Alarm/↓ or Scale/↑ button for 3 seconds or more to return to Measuring Mode.

7.4 DEADBAND

Once a high (low) trip alarm is ON, the alarm stays ON until the data becomes lower (higher) than a certain range from the setpoint, which prevents the alarm output from chattering when the display value fluctuates slightly near the setpoint. This range is called deadband (hysteresis) and can be set within the range of 0000 to 9999. The default value is 0001.

7.4.1 OPERATING PROCEDURE

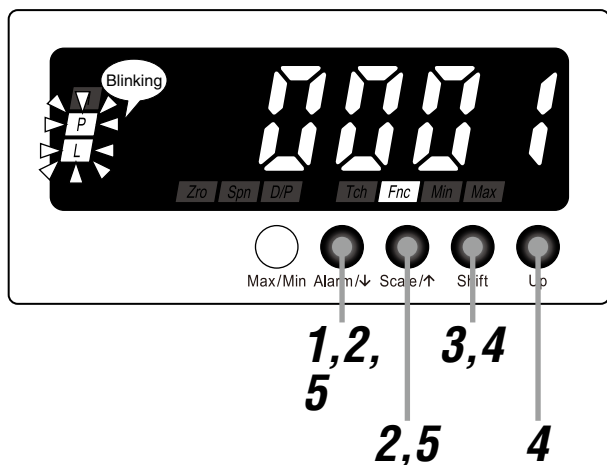

NOTE

The following figures are display examples. The displays depend on the settings.

1 Hold down Alarm/↓ button for 3 seconds or more to move on to Alarm Setting Mode.

- The alarm point is indicated.
- 'H', 'L' and 'Fnc' indicators turn on.

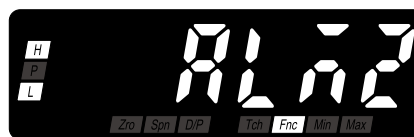

2 Press Alarm/↓ or Scale/↑ button to go to the L (H) deadband setting.

- The L (H) deadband is indicated.
- 'L' ('H') and 'P' indicators blink and 'Fnc' indicator turns on.



■ Display in setting H deadband

NOTE

The L (H) deadband is indicated within the range of 0000 to 9999 depending on the setting.

3 Press Shift button to shift the display into the setting standby mode.

- The fourth digit starts blinking, to which you can apply changes.

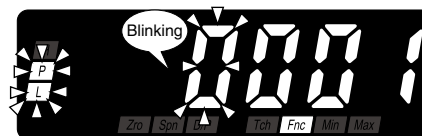

4 Press Shift and Up buttons to set the L (H) deadband.

- Set within the range of 0000 to 9999.

NOTE

Set the deadband for the setpoint. The decimal point is not indicated.

5 Press Alarm/↓ or Scale/↑ button to apply the new setting.

- And the next parameter setting is indicated.

NOTE

- Press Alarm/↓ button, and the L (H) trip delay will be indicated within the range of 00 to 99 depending on the setting.
 - Press Scale/↑ button, and the L (H) trip action 'LMLO' or 'LMHI' will be indicated depending on the setting.
-

6 ■ TO GO ON TO SET ANOTHER DEADBAND,
Repeat operation from Step 2.

■ TO SET THE NEXT PARAMETER,
Skip to Step 2 in "7.5 TRIP DELAY"

■ TO QUIT,
Hold down Alarm/↓ or Scale/↑ button for 3 seconds or more to return to Measuring Mode.

7.5 TRIP DELAY

Alarm output is provided when the display value exceeds the setpoint and stayed for the specified time duration, which prevents the alarm output from being provided by a sudden change such like external disturbance and starting current. This time duration is called trip delay and can be set within the range of 0 to 99 seconds. The default value is 0 second.

7.5.1 OPERATING PROCEDURE

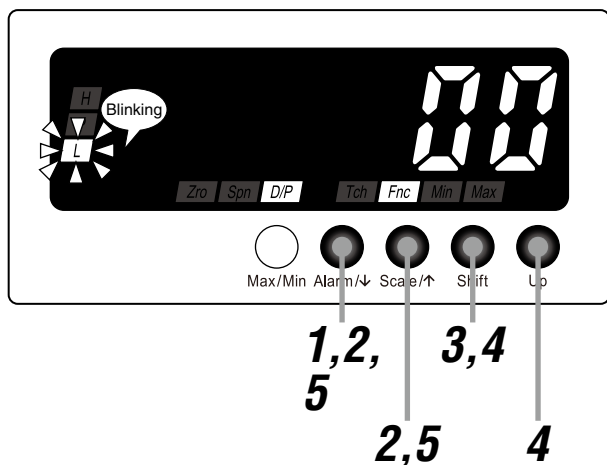

NOTE

The following figures are display examples. The displays depend on the settings.

1 Hold down Alarm/↓ button for 3 seconds or more to move on to Alarm Setting Mode.

- The alarm point is indicated.
- 'H', 'L' and 'Fnc' indicators turn on.

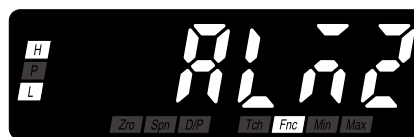

2 Press Alarm/↓ or Scale/↑ button to go to the L (H) trip delay setting.

- The L (H) trip delay is indicated.
- 'L' ('H') indicator blinks, 'D/P' and 'Fnc' indicators turn on.

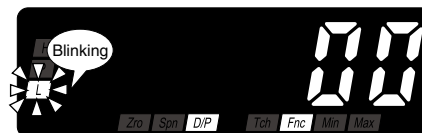

■ Display in setting H trip delay

NOTE

The trip delay is indicated within the range of 00 to 99 depending on the setting.

3 Press Shift button to shift the display into the setting standby mode.

- The second digit starts blinking, to which you can apply changes.

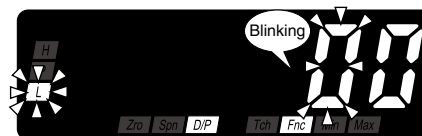

.....

4 Press Shift and Up buttons to set the L (H) trip delay.

- Set within the range of 00 to 99.

.....

5 Press Alarm/↓ or Scale/↑ button to apply the new setting.

- And the next parameter setting is indicated.

NOTE

- Press Alarm/↓ button, and the L (H) coil at alarm 'RYEN' or 'RYDN' will be indicated depending on the setting.
 - Press Scale/↑ button, and the L (H) deadband will be indicated within the range of 0000 to 9999 depending on the setting.
-

.....

6 ■ TO GO ON TO SET ANOTHER TRIP DELAY,
Repeat operation from Step 2.

■ TO SET THE NEXT PARAMETER,

Skip to Step 2 in "7.6 ALARM OUTPUT LOGIC (coil energized or de-energized at alarm)".

■ TO QUIT,

Hold down Alarm/↓ or Scale/↑ button for 3 seconds or more to return to Measuring Mode.

7.6 ALARM OUTPUT LOGIC (coil energized or de-energized at alarm)

Alarm output logic can be selected. This parameter is called energizing direction and coil energized 'RYEN' or de-energized 'RYDN' at alarm can be selected. In selecting coil de-energized at alarm, the alarm output logic is inverted. The default setting is coil energized.

7.6.1 OPERATING PROCEDURE

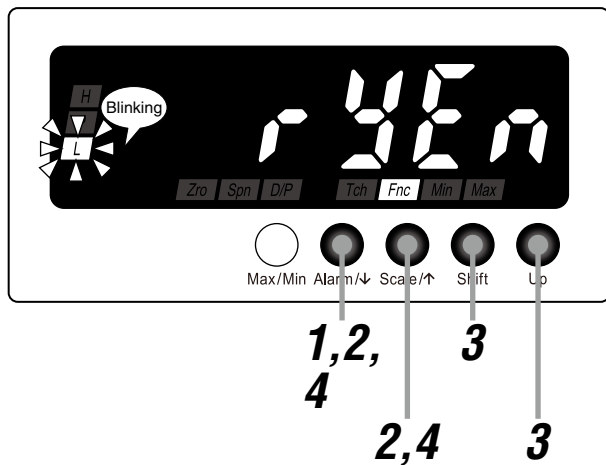

NOTE

- Procedures to change 'RYEN' to 'RYDN' are described here.
- To change 'RYDN' to 'RYEN', the procedures are same. Select 'RYEN' in Step 3.

1 Hold down Alarm/↓ button for 3 seconds or more to move on to Alarm Setting Mode.

- The alarm point is indicated.
- 'H', 'L' and 'Fnc' indicators turn on.



2 Press Alarm/↓ or Scale/↑ button to go to the setting of the L (H) coil at alarm.

- 'RYEN' is indicated.
- 'L' ('H') indicator blinks and 'Fnc' indicator turns on.

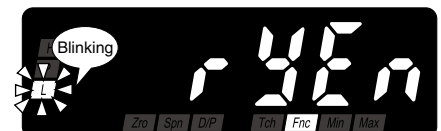

■ Display in setting H coil at alarm

3 Press Shift or Up button to select 'RYDN'.

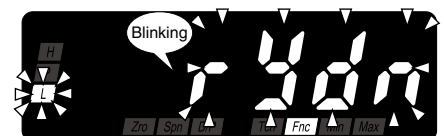

.....

4 Press Alarm/↓ or Scale/↑ button to apply the new setting.

- And the next parameter setting is indicated.

NOTE

- Press Alarm/↓ button, and the H alarm setpoint (or main display blinking at alarm) will be indicated within the range of -19999 to 19999 (or 'B 0', 'B 1', 'B 2', 'B 3' or 'B 4') depending on the setting.
 - Press Scale/↑ button, and the L (H) trip delay will be indicated within the range of 00 to 99 depending on the setting.
-

.....

5 ■ TO GO ON TO SET ANOTHER COIL AT ALARM,

Repeat operation from Step 2.

■ TO SET THE NEXT PARAMETER,

Skip to Step 2 in "7.7 MAIN DISPLAY BLINKING AT ALARM".

■ TO QUIT,

Hold down Alarm/↓ or Scale/↑ button for 3 seconds or more to return to Measuring Mode.

7.7 MAIN DISPLAY BLINKING AT ALARM

Main display blinking interval at alarm can be specified. The interval can be selected among those shown in the following table.

■ BLINKING INTERVAL AT ALARM

DISPLAY	FUNCTION	DEFAULT VALUE
	No blinking	
	Blinking in 1.0 second intervals	
	Blinking in 0.5 second intervals	
	Blinking in 0.2 second intervals	
	Blinking in 0.1 second intervals	

7.7.1 OPERATING PROCEDURE

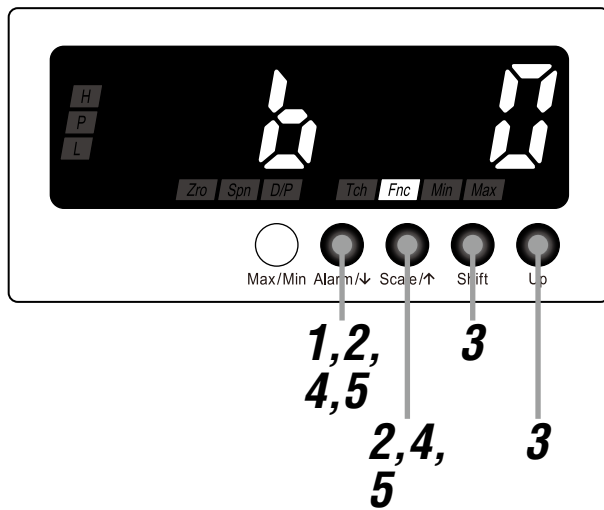

NOTE

The following figures are display examples. The displays depend on the settings.

1 Hold down Alarm/↓ button for 3 seconds or more to move on to Alarm Setting Mode.

- The alarm point is indicated.
- 'H', 'L' and 'Fnc' indicators turn on.

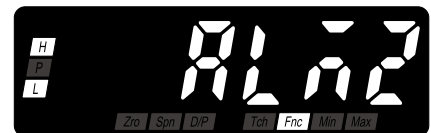

2 Press Alarm/↓ or Scale/↑ button to go to the setting of the main display blinking at alarm.

- The main display blinking at alarm is indicated.
- 'Fnc' indicator turns on.



NOTE

'B 0', 'B 1', 'B 2', 'B 3' or 'B 4' is indicated depending on the setting.

.....

3 Press Shift or Up button to select.

- Select one among 'B 0', 'B 1', 'B 2', 'B 3' and 'B 4'.

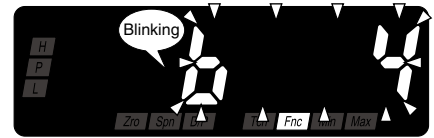

.....

4 Press Alarm/↓ or Scale/↑ button to apply the new setting.

- And the next parameter setting is indicated.

NOTE

- Press Alarm/↓ button, and the alarm point 'ALM2' will be indicated.
 - Press Scale/↑ button, and the H coil at alarm 'RYEN' or 'RYDN' will be indicated depending on the setting.
-

.....

5 Hold down Alarm/↓ or Scale/↑ button for 3 seconds or more to return to Measuring Mode.

8. AVERAGING INPUT

Moving average processing of measured values is configurable. The number of samples in processing the moving average can be selected in the following table. This operation averages sampled values, and then, averages with a new sample added and the oldest one omitted. Such operation is repeated as shown in the following figure. For instance, when 'A 4' is selected, the moving average processing with 4 samples (100 millisecond intervals) is repeated. Moving average is used to remove periodic varied noise superimposed on the input signal and suppress the display flickering.

■ NUMBER OF SAMPLES

DISPLAY	FUNCTION	DEFAULT VALUE
OFF	No moving averaging	A 4
A 2	Moving average with 2 samples (50 millisecond intervals)	
A 4	Moving average with 4 samples (100 millisecond intervals)	
A 8	Moving average with 8 samples (200 millisecond intervals)	
A 16	Moving average with 16 samples (400 millisecond intervals)	
A 32	Moving average with 32 samples (800 millisecond intervals)	
A 64	Moving average with 64 samples (1.6 second intervals)	

■ EXAMPLE OF MOVING AVERAGE WITH 4 SAMPLES

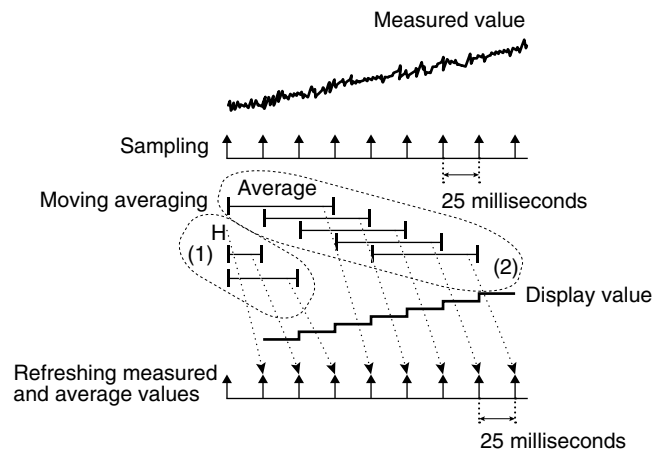

- (1) The moving average operation starts immediately after the power is on or the moving average is set. Until the sampling No. reaches the set value, all samples are averaged every 25 milliseconds.
- (2) After the sampling No. reaches the set value, a new sample is added to be averaged with the oldest one omitted. Such operation is repeated.

8.1 OPERATING PROCEDURE

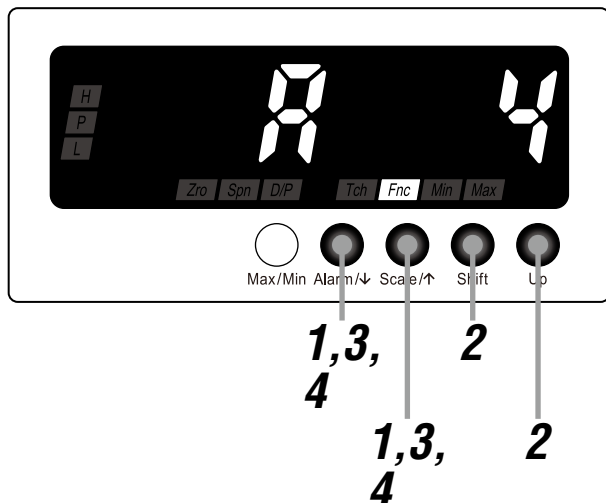

NOTE

The following figures are display examples. The displays depend on the settings.

1 Hold down Alarm/↓ and Scale/↑ buttons at once for 3 seconds or more to move on to Advanced Setting Mode.

- The moving average sampling No. is indicated.
- 'Fnc' indicator turns on.

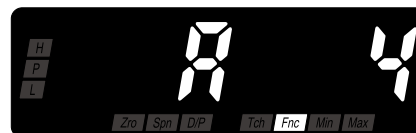

NOTE

'A OFF', 'A 2', 'A 4', 'A 8', 'A 16', 'A 32' or 'A 64' is indicated depending on the setting.

2 Press Shift or Up button to select.

- Select one among 'A OFF', 'A 2', 'A 4', 'A 8', 'A 16', 'A 32' and 'A 64'.

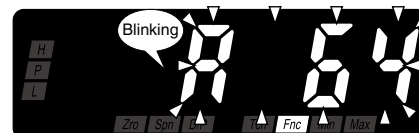

3 Press Alarm/↓ or Scale/↑ button to apply the new setting.

- And the next parameter setting is indicated.

NOTE

- Press Alarm/↓ button, and the low-end cutout 'DOFF' or 'D ON' will be indicated depending on the setting.
- Press Scale/↑ button, and the version indication will be indicated.

4 Hold down Alarm/↓ or Scale/↑ button for 3 seconds or more to return to Measuring Mode.

9. INDICATING INPUT LESS THRESHOLD VALUE AS 0%

An input signal less than the preset cutout value can be forcibly cut to the value of display scaling ZERO (figure below). This parameter is called low-end cutout and the value is called low-end cutout value. Enable the low-end cutout first (table below) and set the low-end cutout value within the range of 0.0 to 99.9%. The low-end cutout is effective to eliminate display error or fluctuation of the display values near the input 0% especially when the linearizer is set to "square root extraction"

■ LOW-END CUTOUT

DISPLAY	FUNCTION	DEFAULT VALUE
<code>daFF</code>	Low-end cutout OFF	<code>daFF</code>
<code>d_on</code>	Low-end cutout ON	

■ SETTING RANGE

Set the low-end cutout value in the percentage of the input span (input scaling SPAN - input scaling ZERO) within the range of 0.0 to 99.9%. The default value is 00.0.

■ DISPLAY EXAMPLE WITH LOW-END CUTOUT ON

e.g. With the linearizer set to square root extraction and low-end cutout value set to 4.0%, the input less than 4% (display value less than 20%) will be indicated as 0% input (value of display scaling ZERO).

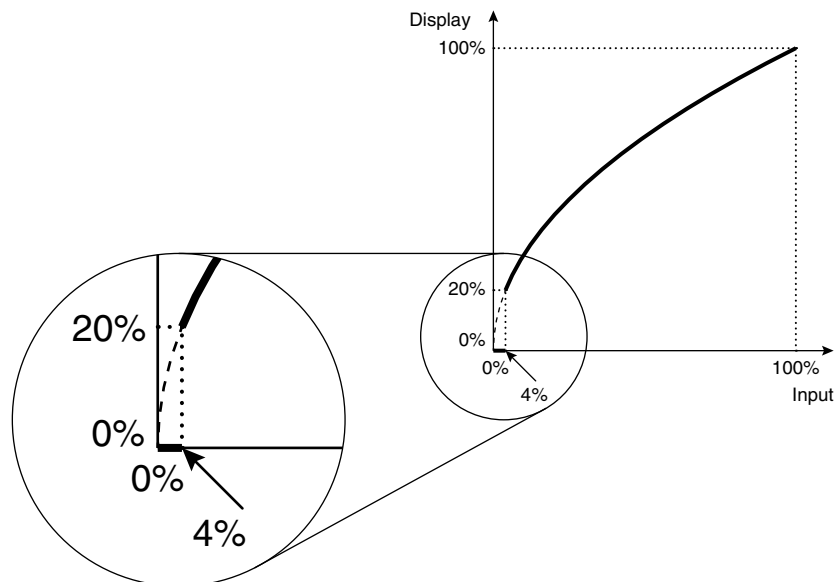

9.1 LOW-END CUTOUT

9.1.1 OPERATING PROCEDURE

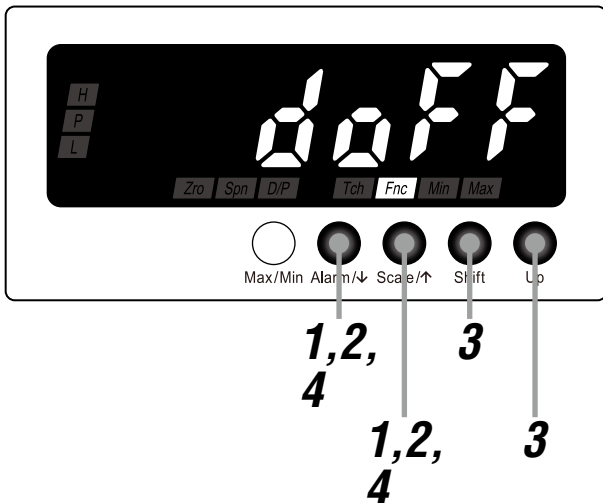

NOTE

- Procedures to change 'DOFF' to 'D ON' are described here.
- To change 'D ON' to 'DOFF', the procedures are the same. Select 'DOFF' in Step 3.

1 Hold down Alarm/↓ and Scale/↑ buttons at once for 3 seconds or more to move on to Advanced Setting Mode.

- The moving average sampling No. is indicated.
- 'Fnc' indicator turns on.

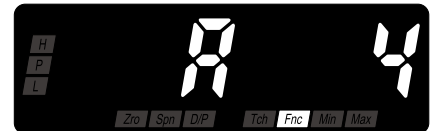

NOTE

'AOFF', 'A 2', 'A 4', 'A 8', 'A 16', 'A 32' or 'A 64' is indicated depending on the setting.

2 Press Alarm/↓ or Scale/↑ button to go to the low-end cutout setting.

- 'DOFF' is indicated.
- 'Fnc' indicator turns on.



3 Press Shift or Up button to select 'D ON'.

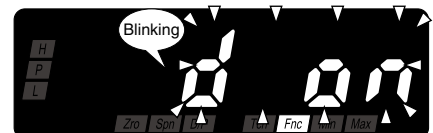

.....

4 Press Alarm/↓ or Scale/↑ button to apply the new setting.

- And the next parameter setting is indicated.

NOTE

- Press Alarm/↓ button, and the low-end cutout value will be indicated within the range of 'D00.0' to 'D99.9' depending on the setting. When low-end cutout OFF is selected, the brightness 'C 1', 'C 2', 'C 3', 'C 4' or 'C 5' will be indicated depending on the setting.
 - Press Scale/↑ button, and the moving average sampling No. 'AOFF', 'A 2', 'A 4', 'A 8', 'A 16', 'A 32' or 'A 64' will be indicated depending on the setting.
-

.....

5 ■ TO GO ON TO SET THE LOW-END CUTOUT VALUE,
Skip to Step 2 in "9.2 LOW-END CUTOUT VALUE."

■ TO QUIT,

Hold down Alarm/↓ or Scale/↑ button for 3 seconds or more to return to Measuring Mode.

9.2 LOW-END CUTOUT VALUE

9.2.1 OPERATING PROCEDURE

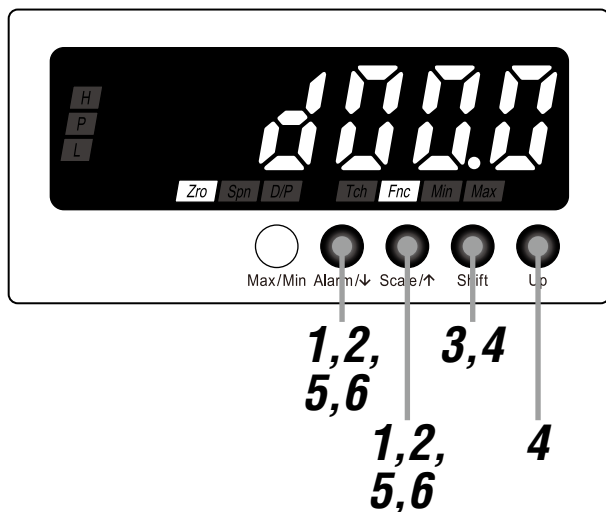

NOTE

The following figures are display examples. The displays depend on the settings.

1 Hold down Alarm/↓ and Scale/↑ buttons at once for 3 seconds or more to move on to Advanced Setting Mode.

- The moving average sampling No. is indicated.
- 'Fnc' indicator turns on.



NOTE

'A OFF', 'A 2', 'A 4', 'A 8', 'A 16', 'A 32' or 'A 64' is indicated depending on the setting.

2 Press Alarm/↓ or Scale/↑ button to go to the low-end cutout value setting.

- The low-end cutout value is indicated.
- 'Zro' and 'Fnc' indicators turn on.



NOTE

The low-end cutout value is indicated within the range of 'D00.0' to 'D99.9' depending on the setting.

3 Press Shift button to shift the display into the setting standby mode.

- The third digit starts blinking, to which you can apply changes.

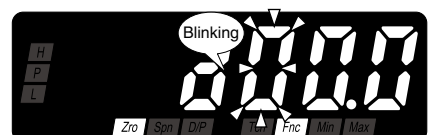

.....

4 Press Shift and Up buttons to set the low-end cutout value.

- Set within the range of 'D00.0' to 'D99.9'.

NOTE

Set the value for the display scaling. The decimal point is not indicated.

.....

5 Press Alarm/↓ or Scale/↑ button to apply the new setting.

- And the next parameter setting is indicated.

NOTE

- Press Alarm/↓ button, and the brightness 'C 1', 'C 2', 'C 3', 'C 4' or 'C 5' will be indicated depending on the setting.
 - Press Scale/↑ button, and the low-end cutout 'D ON' will be indicated.
-

.....

6 Hold down Alarm/↓ or Scale/↑ button for 3 seconds or more to return to Measuring Mode.

10. ADJUSTING BRIGHTNESS OF DISPLAY

The brightness of the display can be adjusted (figures below). The brightness can be selected in the following table.

■ DISPLAY BRIGHTNESS

DISPLAY	FUNCTION	DEFAULT VALUE
	Brightness level 1 (dark)	
	Brightness level 2	
	Brightness level 3	
	Brightness level 4	
	Brightness level 5 (bright)	

■ ADJUSTMENT IMAGE

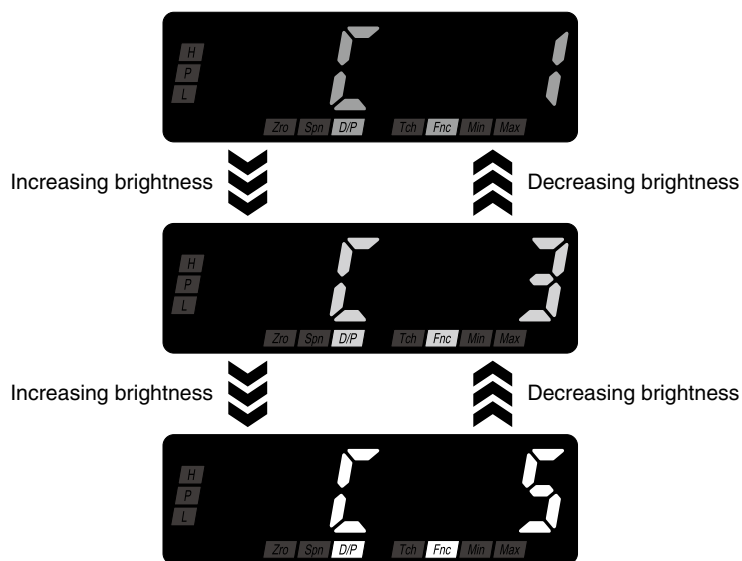

10.1 OPERATING PROCEDURE

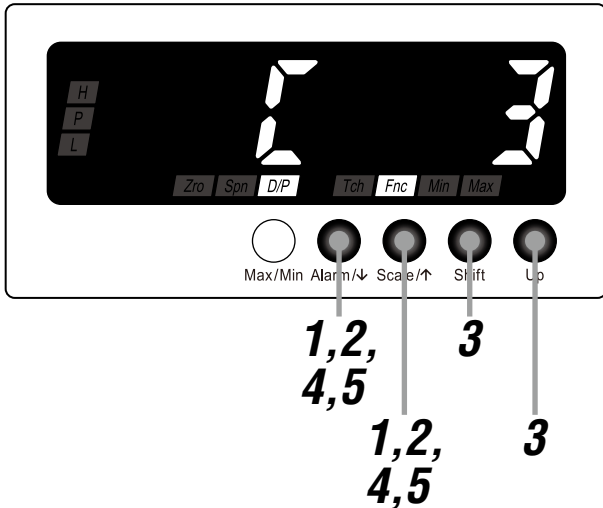

NOTE

The following figures are display examples. The displays depend on the settings.

1 Hold down Alarm/↓ and Scale/↑ buttons at once for 3 seconds or more to move on to Advanced Setting Mode.

- The moving average sampling No. is indicated.
- 'Fnc' indicator turns on.

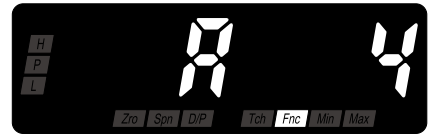

NOTE

'A OFF', 'A 2', 'A 4', 'A 8', 'A 16', 'A 32' or 'A 64' is indicated depending on the setting.

2 Press Alarm/↓ or Scale/↑ button to go to the brightness setting.

- The brightness is indicated.
- 'D/P' and 'Fnc' indicators turn on.

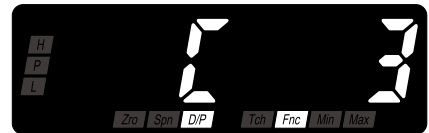

NOTE

'C 1', 'C 2', 'C 3', 'C 4' or 'C 5' is indicated depending on the setting.

3 Press Shift or Up button to select.

- Select one among 'C 1', 'C 2', 'C 3', 'C 4' and 'C 5'.

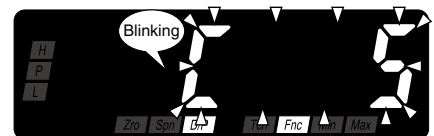

.....

4 Press Alarm/↓ or Scale/↑ button to apply the new setting.

- And the next parameter setting is indicated.

NOTE

- Press Alarm/↓ button, and the setting time out will be indicated within the range of 'R 00' to 'R 99' depending on the setting.
 - Press Scale/↑ button, and the low-end cutout value will be indicated within the range of 'D00.0' to 'D99.9' depending on the setting. The low-end cutout 'DOFF' will be indicated with the cutout set to OFF.
-

.....

5 Hold down Alarm/↓ or Scale/↑ button for 3 seconds or more to return to Measuring Mode.

11. GOING BACK AUTOMATICALLY TO MEASURING MODE

The display goes back automatically to Measuring Mode if the front buttons are left untouched for the specified time period while it is in one of the setting modes. This time period is called setting time out and can be set within the range of 1 to 99 seconds (Table 1). With the value set to 'R 00', the display must always be exited manually from the setting mode. The display does not go back automatically to Measuring Mode depending on the modes (Table 2).

■ TABLE 1: SETTING TIME OUT

DISPLAY	FUNCTION	DEFAULT VALUE
r 00	Setting time out disabled	r 60
r 01 to r 99	1 to 99 seconds	

■ TABLE 2: SETTING TIME OUT IN EACH MODE

MODE	OPERATION	SETTING TIME OUT
Measuring Mode	Confirming alarm setpoint	Enabled
	Displaying MAX or MIN value	Disabled
	Executing Forced Zero	Disabled
Scaling Setting Mode		Enabled
Alarm Setting Mode		Enabled
Advanced Setting Mode		Enabled
Lockout Setting Mode		Enabled

11.1 OPERATING PROCEDURE

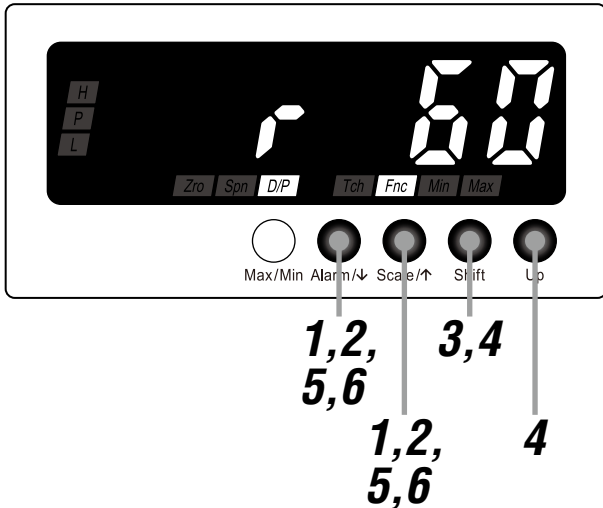

NOTE

The following figures are display examples. The displays depend on the settings.

1 Hold down Alarm/↓ and Scale/↑ buttons at once for 3 seconds or more to move on to Advanced Setting Mode.

- The moving average sampling No. is indicated.
- 'Fnc' indicator turns on.

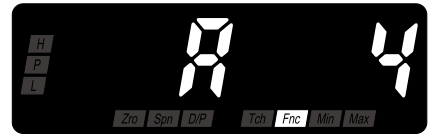

NOTE

'A OFF', 'A 2', 'A 4', 'A 8', 'A 16', 'A 32' or 'A 64' is indicated depending on the setting.

2 Press Alarm/↓ or Scale/↑ button to go to the setting time out setting.

- The setting time out is indicated.
- 'D/P' and 'Fnc' indicators turn on.

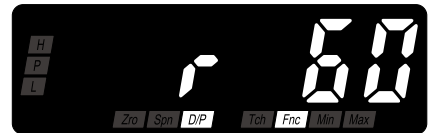

NOTE

The setting time out is indicated within the range of 'R 00' to 'R 99' depending on the setting.

3 Press Shift button to shift the display into the setting standby mode.

- The second digit starts blinking, to which you can apply changes.

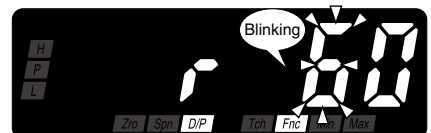

4 Press Shift and Up buttons to set the setting time out.

- Set within the range of 'R 00' to 'R 99'

.....
5 Press Alarm/↓ or Scale/↑ button to apply the new setting.

- And the next parameter setting is indicated.

NOTE

- Press Alarm/↓ button, and the transition time to Lockout Setting Mode will be indicated within the range of 'P 00' to 'P 99' depending on the setting.
 - Press Scale/↑ button, and the brightness 'C 1', 'C 2', 'C 3', 'C 4' or 'C 5' will be indicated depending on the setting.
-

.....
6 Hold down Alarm/↓ or Scale/↑ button for 3 seconds or more to return to Measuring Mode.

12. ADJUSTING DISPLAY REFRESHING RATE

The display refreshing rate can be set within the range of 0.1 to 99.9 seconds. With this value set to 00.0, the refreshing rate will be 50 milliseconds (table below). When the input signal changes rapidly, the display refreshing rate can be slowed to suppress the display flickering.

■ DISPLAY REFRESHING RATE

DISPLAY	FUNCTION	DEFAULT VALUE
<code>F000</code>	50 milliseconds	<code>F000</code>
<code>F00.1</code> to <code>F99.9</code>	0.1 to 99.9 seconds	

■ DISPLAY REFRESHING IMAGE

e.g. Refreshing rate 0.2 seconds

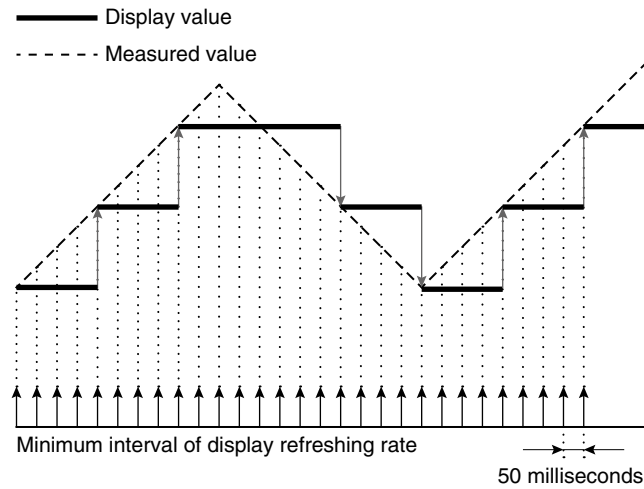

12.1 OPERATING PROCEDURE

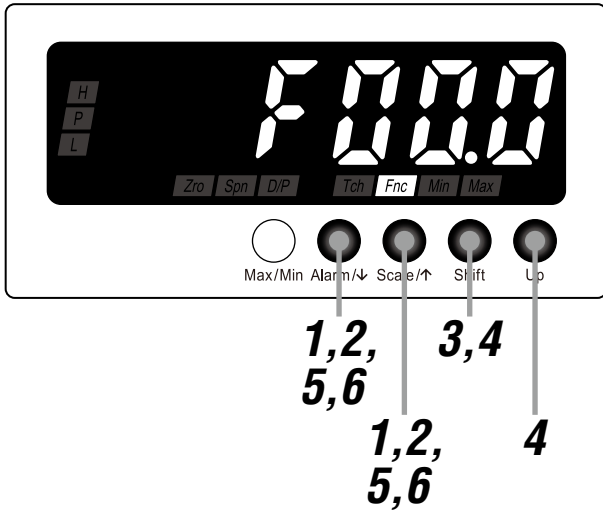

NOTE

The following figures are display examples. The displays depend on the settings.

1 Hold down Alarm/↓ and Scale/↑ buttons at once for 3 seconds or more to move on to Advanced Setting Mode.

- The moving average sampling No. is indicated.
- 'Fnc' indicator turns on.

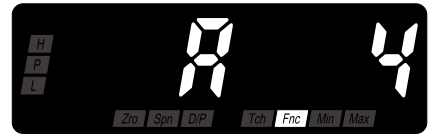

NOTE

'A OFF', 'A 2', 'A 4', 'A 8', 'A 16', 'A 32' or 'A 64' is indicated depending on the setting.

2 Press Alarm/↓ or Scale/↑ button to go to the display refreshing rate setting.

- The display refreshing rate is indicated.
- 'Fnc' indicator turns on.



NOTE

The display refreshing rate is indicated within the range of 'F00.0' to 'F99.9' depending on the setting.

3 Press Shift button to shift the display into the setting standby mode.

- The third digit starts blinking, to which you can apply changes.

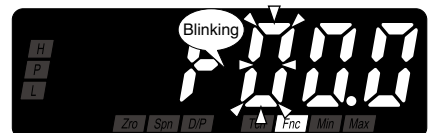

4 Press Shift and Up buttons to set the display refreshing rate.

- Set within the range of 'F00.0' to 'F99.9'.

.....
5 Press Alarm/↓ or Scale/↑ button to apply the new setting.

- And the next parameter setting is indicated.

NOTE

- Press Alarm/↓ button, and the version indication will be indicated.
 - Press Scale/↑ button, and the transition time to Lockout Setting Mode will be indicated within the range of 'P 00' to 'P 99' depending on the setting.
-

.....
6 Hold down Alarm/↓ or Scale/↑ button for 3 seconds or more to return to Measuring Mode.

13. USEFUL FUNCTIONS

13.1 CONFIRMING ALARM SETPOINTS

The alarm setpoints set in Alarm Setting Mode can be confirmed while in Measuring Mode.

Each time pressing Alarm/↓ button during Measuring Mode, the indication is switched in the order of L alarm setpoint to H alarm setpoint and back to original indication.

■ PROCEDURE TO CONFIRM ALARM SETPOINTS

Each time pressing Alarm/↓ button in Measuring Mode, the indication is changed from the present value to L alarm setpoint to H alarm setpoint and back to present value.

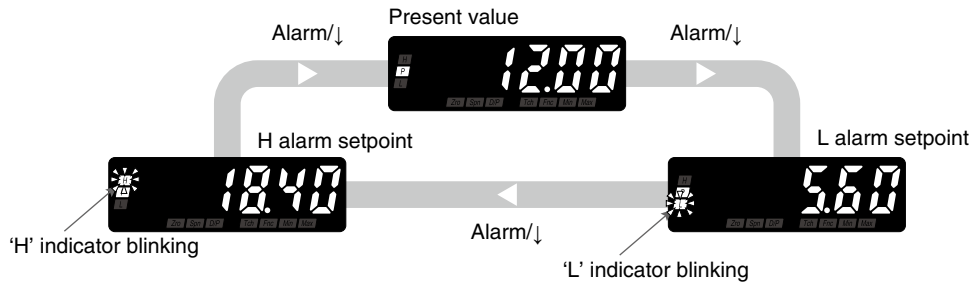

*1 Display depends on the specifications, settings and input.

NOTE

- When “No alarm” is selected for the alarm point parameter in Alarm Setting Mode, alarm setpoints cannot be confirmed.
- The alarm setpoints can be confirmed even when MAX or MIN value is indicated. After confirmation, the indication will be back to MAX or MIN value.
- The alarm setpoints can be confirmed while in Forced Zero mode. After confirmation, the indication will be back to the display value after Forced Zero.
- The alarm setpoints cannot be confirmed while ‘S.ERR’ or ‘O.L.’ is indicated. Increase or decrease the input signal within the conformance range and then confirm the setpoints.

13.2 FORCING THE PRESENT DISPLAY VALUE TO ZERO

The display value can be forced to 0 while in Measuring Mode. Press Up button during Measuring Mode to shift the present display value to zero and to continue measuring in reference to this point. This operation is called Forced Zero. This function can be used for applications such as measuring the weight of the contents in a container by canceling the weight of the empty container, or indicating the weight of each material adding into a container one after another.

■ DISPLAY VALUE IN EXECUTING AND CANCELING FORCED ZERO

The display value changes as shown in the following figure when Forced Zero is executed or canceled while in measuring.

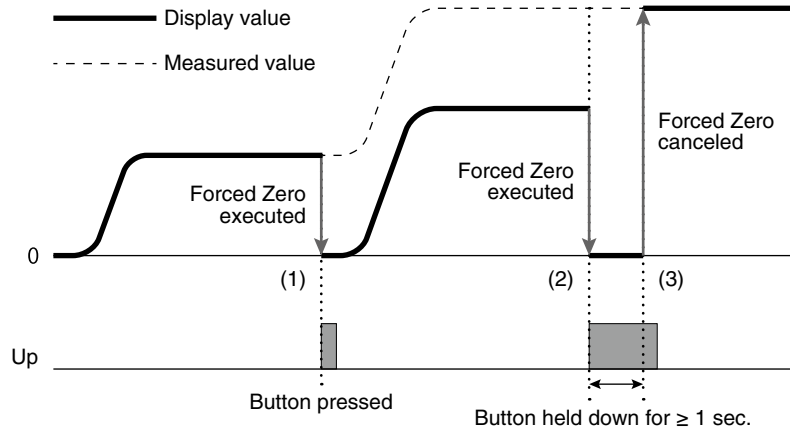

- (1) Press Up button to shift the present display value to zero.
- (2) Press Up button again for 1 second or more to cancel the Forced Zero mode. The display value is forced to 0 once.
- (3) Then the display is back to indicate the measured value.

■ OPERATING PROCEDURE TO EXECUTE/CANCEL FORCED ZERO

- (1) Press Up button in Measuring Mode to execute the Forced Zero.
- (2) Hold down Up button for 1 second or more to cancel the Forced Zero mode.

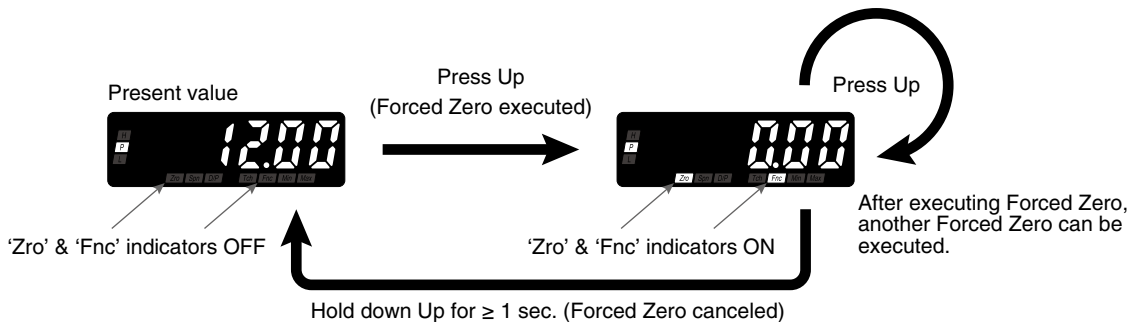

*1 Display depends on the specifications, settings and input.

NOTE

- Forced Zero cannot be executed or canceled while in the MAX/MIN Value Display mode.
- Forced Zero value is stored in memory even when the power is removed.
- Forced Zero cannot be executed or canceled while 'S.ERR' or 'O.L.' is indicated. Increase or decrease the input signal within the conformance range and then execute the Forced Zero again.

13.3 RETAINING MAX AND MIN VALUES

MAX and MIN values can be confirmed while in Measuring Mode. Each time pressing Max/Min button during Measuring Mode, the indication is switched in the order of MAX value to MIN value and back to original indication.

■ MAX AND MIN VALUES

MAX and MIN values are updated while in measuring.

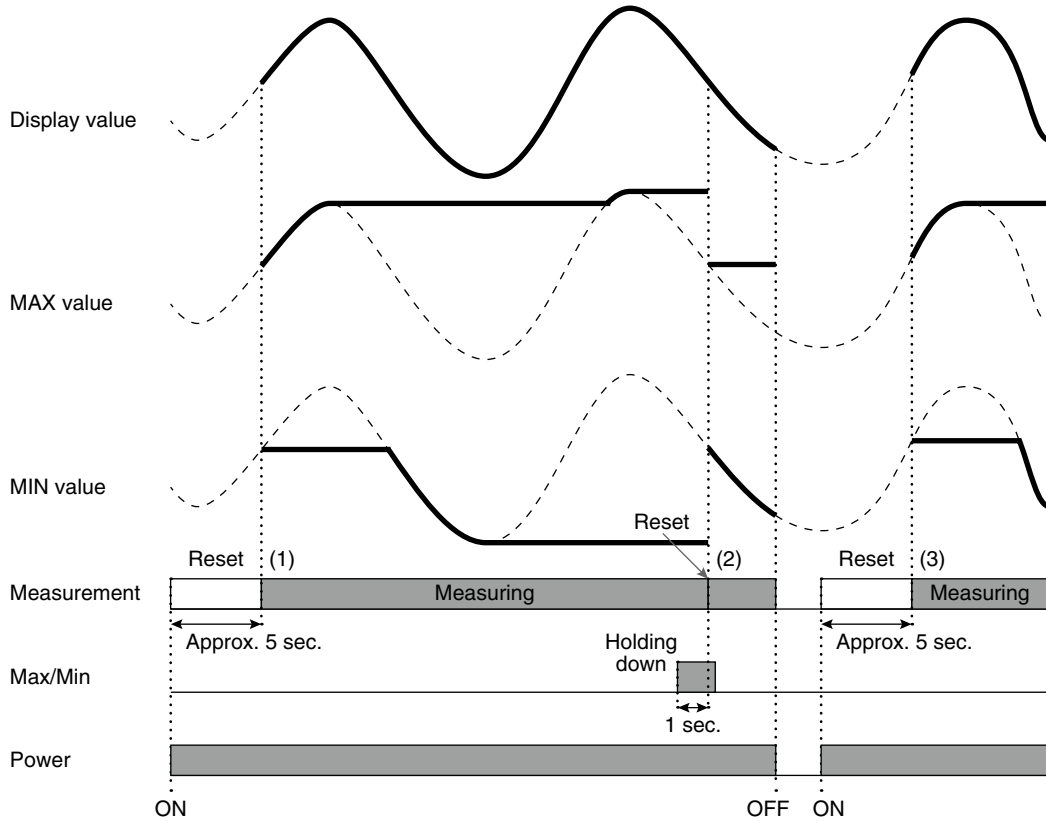

- (1) The internal memory is reset for approx. 5 seconds after the power is on, and the unit starts to measure MAX and MIN values.
- (2) Hold down Max/Min button for 1 second or more to reset the MAX and MIN values and then the unit starts to measure MAX and MIN values again.
- (3) The internal memory is reset for approx. 5 seconds after the power is off and on again, and then the unit starts to measure MAX and MIN values again.

■ PROCEDURE TO CONFIRM MAX OR MIN VALUE

- (1) Each time pressing Max/Min button during Measuring Mode, the indication is changed from the present value to MAX value, MIN value, and back to present value.
- (2) Hold down Max/Min button for 1 second or more to reset the MAX and MIN values and indicate new MAX and MIN values. The MAX and MIN values are reset when the power is turned off.

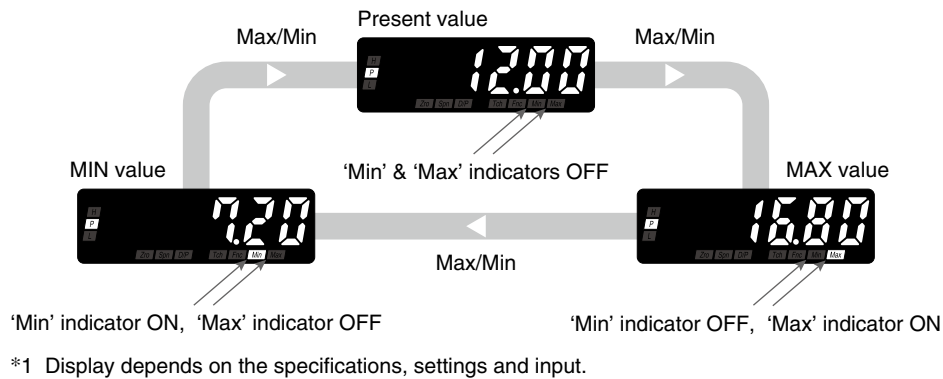

NOTE

- The MAX and MIN values are not reset even when the Forced Zero is executed or canceled.
- Pressing Max/Min button while in confirming the alarm setpoints switches the indication to MAX or MIN value.
- MAX and MIN values are not indicated while 'S.ERR' or 'O.L.' is indicated. Increase or decrease the input signal within the conformance range and then press Max/Min button again.

13.4 LIMITING BUTTON OPERATION

Transition from Measuring Mode to each setting mode can be limited. With this setting, the transition to each mode by holding down the buttons will be disabled. In Lockout Setting Mode, the lockout per mode is selectable.

■ LOCKOUT SETTING

Following 4 lockout settings are available.

PARAMETER	INDICATORS	DISPLAY	FUNCTION	DEFAULT VALUE
Alarm setting lockout	D/P, Fnc	RoFF	Unlock Alarm Setting Mode	RoFF
		R on	Lock Alarm Setting Mode	
Scaling setting lockout		S oFF	Unlock Scaling Setting Mode	S oFF
		S on	Lock Scaling Setting Mode	
Advanced setting lockout		doFF	Unlock Advanced Setting Mode	doFF
	d on	Lock Advanced Setting Mode		
Forced zero lockout	z oFF	Unlock (Enable) Forced Zero operation	z on	
	z on	Lock (Disable) Forced Zero operation		

13.4.1 OPERATING PROCEDURE

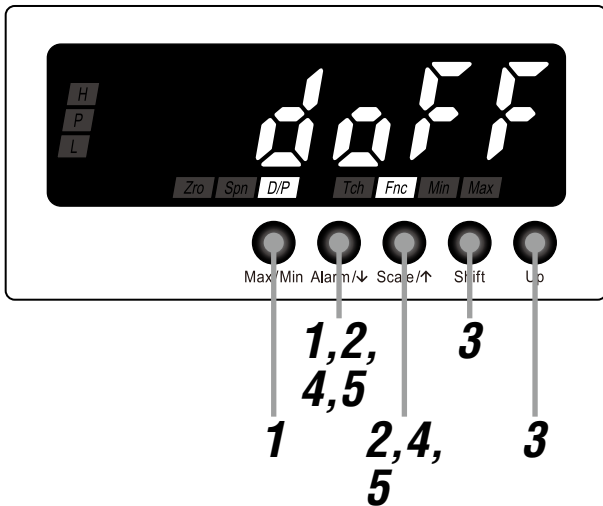

NOTE

- Procedures to lock the advanced setting mode are described here. The procedures to lock other setting modes are same. Select your desired mode to lock in Step 2.
- To cancel the limitation, select 'xOFF' in Step 3.

1 Hold down Max/Min and Alarm/↓ buttons at once for a preset time duration to move on to Lockout Setting Mode.

- The alarm setting lockout is indicated.
- 'D/P' and 'Fnc' indicators turn on.

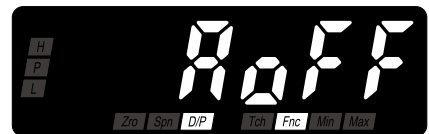

NOTE

'AOFF' or 'A ON' is indicated depending on the setting.

2 Press Alarm/↓ or Scale/↑ button to go to the advanced setting lockout setting.

- 'DOFF' is indicated.
- 'D/P' and 'Fnc' indicators turn on.

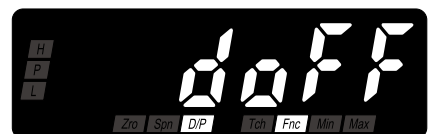

.....

3 Press Shift or Up button to select 'D ON'.

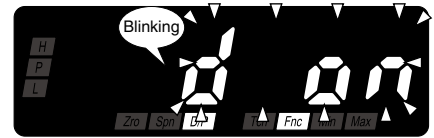

.....

4 Press Alarm/↓ or Scale/↑ button to apply the new setting.

- And the next parameter setting is indicated.

NOTE

- Press Alarm/↓ button, and the forced zero lockout 'ZOFF' or 'Z ON' will be indicated depending on the setting.
 - Press Scale/↑ button, and the scaling setting lockout 'SOFF' or 'S ON' will be indicated depending on the setting.
-

.....

5 Hold down Alarm/↓ or Scale/↑ button for 3 seconds or more to return to Measuring Mode.

13.5 TRANSITION TIME TO LOCKOUT SETTING MODE

Time duration to hold down the buttons for transition to Lockout Setting Mode can be set within the range of 0 to 99 seconds. The default value is 5 seconds.

13.5.1 OPERATING PROCEDURE

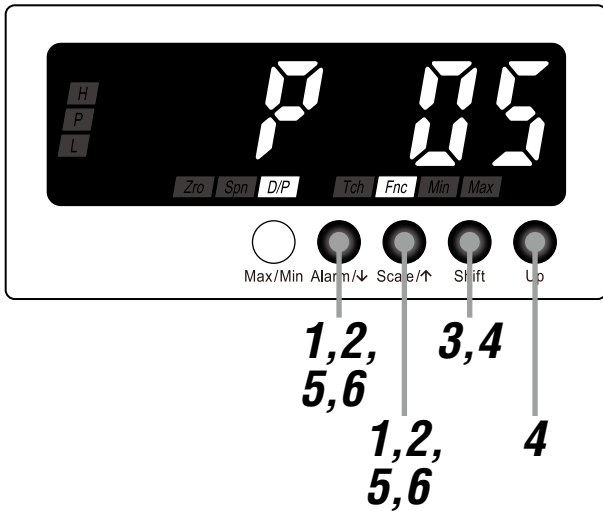

NOTE

The following figures are display examples. The displays depend on the settings.

1 Hold down Alarm/↓ and Scale/↑ buttons at once for 3 seconds or more to move on to Advanced Setting Mode.

- The moving average sampling No. is indicated.
- 'Fnc' indicator turns on.

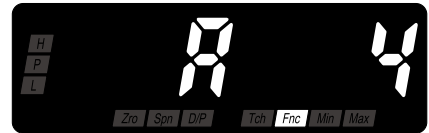

NOTE

'A OFF', 'A 2', 'A 4', 'A 8', 'A 16', 'A 32' or 'A 64' is indicated depending on the setting.

2 Press Alarm/↓ or Scale/↑ button to go to the setting of the transition time to Lockout Setting Mode.

- The transition time to Lockout Setting Mode is indicated.
- 'D/P' and 'Fnc' indicators turn on.



NOTE

The transition time is indicated within the range of 'P 00' to 'P 99' depending on the setting.

3 Press Shift button to shift the display into the setting standby mode.

- The second digit starts blinking, to which you can apply changes.

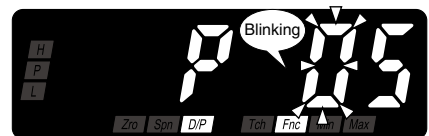

.....

4 Press Shift and Up buttons to set the transition time to Lockout Setting Mode.

- Set within the range of 'P 00' to 'P 99'.

.....

5 Press Alarm/↓ or Scale/↑ button to apply the new setting.

- And the next parameter setting is indicated.

NOTE

- Press Alarm/↓ button, and the display refreshing rate will be indicated within the range of 'F00.0' to 'F99.9' depending on the setting.
 - Press Scale/↑ button, and the setting time out will be indicated within the range of 'R 00' to 'R 99' depending on the setting.
-

.....

6 Hold down Alarm/↓ or Scale/↑ button for 3 seconds or more to return to Measuring Mode.

14. USER CALIBRATION

User calibration is calibration by a customer using customer’s measuring instruments and standards. To calibrate (adjust) the input signal, use “Teach Calibration” function. The unit is calibrated correctly at shipment and therefore there is normally no need for customers to calibrate it.

14.1 TEACH CALIBRATION

You can calibrate the input signal by the Teach Calibration function if you need calibration. Input scaling ZERO and SPAN can be adjusted by applying actual input signals. Please note that we do not warrant the result of your own calibration (adjustment). The internal calibration data is overwritten every time the unit is calibrated and it is stored even if the power is turned off. However the data will be lost after an initialization. Prepare measuring instruments and equipment for calibration by yourselves. Refer to each manual carefully for the instruments and equipment for information on handling them.

14.1.1 TEACH CALIBRATION FLOW

The Teach Calibration is carried out as shown in the following flowchart.

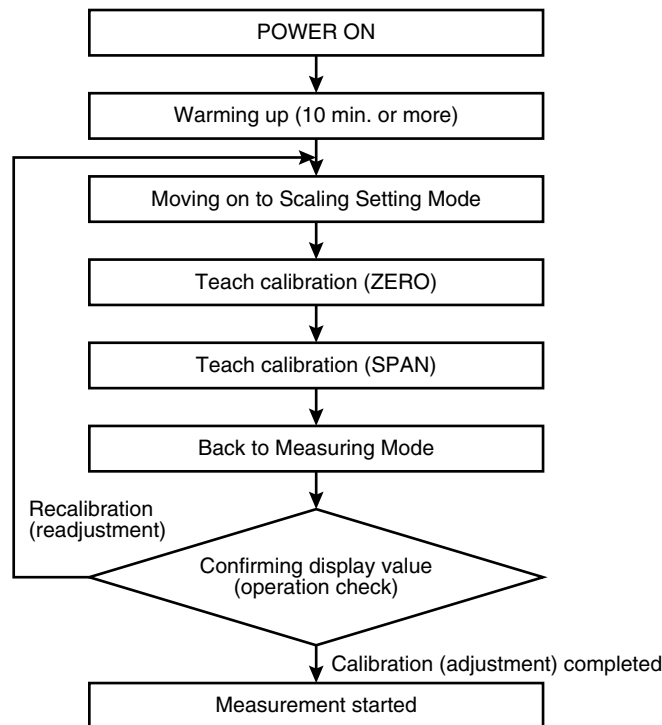

IMPORTANT

- Warm up measuring instruments, equipment and other devices on site for the time specified in each manual, and operate the unit in a stable condition.
- In setting the input scaling ZERO and SPAN using actual inputs, carry out the Teach Calibration within the setting range per input code. Do not set 'input scaling ZERO \geq input scaling SPAN' in carrying out the Teach Calibration.

14.1.2 OPERATING PROCEDURE

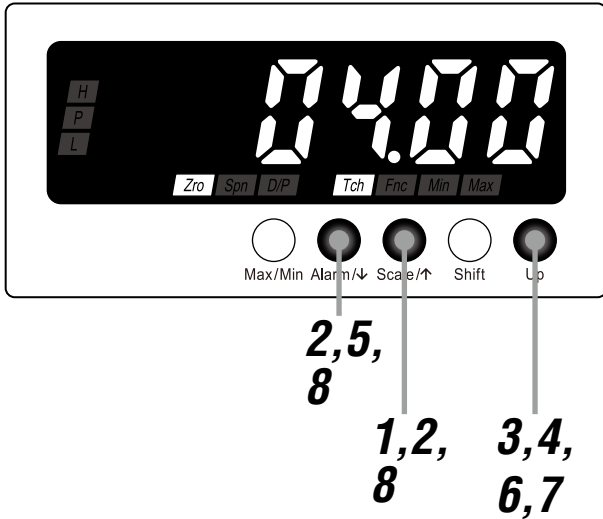

NOTE

The following figures are display examples. The displays depend on the specifications and settings.

1 Hold down Scale/↑ button for 3 seconds or more to move on to Scaling Setting Mode.

- The linearizer is indicated.
- 'D/P' indicator turns on.



IMPORTANT

Warm up the unit for 10 minutes or more before carrying out the Teach Calibration.

2 Press Alarm/↓ or Scale/↑ button to go to the input scaling ZERO setting.

- The input scaling ZERO is indicated.
- 'Zro' and 'Tch' indicators turn on.



NOTE

Skip to Step 5 when the teach calibration (ZERO) is not necessary.

3 Press Up button to go to the teach calibration (ZERO) setting.

- The present input is indicated.
- 'Tch' indicator starts blinking.

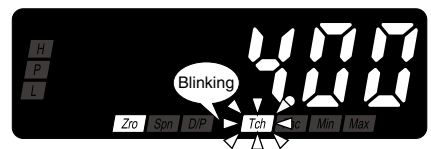

4 Apply 0% input and press Up button to register the value.

- The teach calibration (ZERO) is registered.
- 'Tch' indicator turns ON.



IMPORTANT

Confirm that the input signal is stable before pressing Up button.

5 Press Alarm/↓ button twice to go to the input scaling SPAN setting.

- The input scaling SPAN is indicated.
- 'Spn' and 'Tch' indicators turn on.

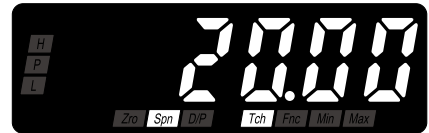

NOTE

Skip to Step 8 when the teach calibration (SPAN) is not necessary.

6 Press Up button to go to the teach calibration (SPAN) setting.

- The present input is indicated.
- 'Tch' indicator starts blinking.

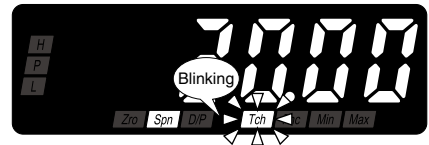

7 Apply 100% input and press Up button to register the value.

- The teach calibration (SPAN) is registered.
- 'Tch' indicator turns ON.



IMPORTANT

Confirm that the input signal is stable before pressing Up button.

8 Hold down Alarm/↓ or Scale/↑ button for 3 seconds or more to return to Measuring Mode.

15. INSPECTION / CLEANING

To use the unit in the normal and best conditions, inspect and clean the unit routinely or periodically.

- When the display and the buttons have dirt, wipe them with wet soft cloth. Do not use organic solvent such like benzine, thinner and alcohol. Doing so may result in deformation or discoloration of the unit.
- Make sure that abnormality such like smokes, unusual smell or abnormal noises is not found. Using the unit continuously with such abnormality may result in a fire or electric shock.
- Check the wiring periodically. In checking the wiring, for safety, interrupt electricity to the power, input and alarm output.
- Make sure periodically that the screws are fixed tightly. Loosened screws may cause drop of the unit.

16. TROUBLESHOOTING

16.1 ERROR MESSAGES

MAIN DISPLAY	ERROR MESSAGE	WHAT TO DO
	Input error, Out of the measurable range	Increase/decrease the input signal until it is back within the measurable range.
	Input overload	Check the wiring.
	Non-volatile memory error (reading)	Initialize the unit to its factory default status at the lockout setting mode.*1
	Non-volatile memory error (writing)	
	Internal data error	Repair is needed if the display does not recover after the power is reset.

*1 If the unit does not recover its function after the initialization, repairing in the factory may be required.

16.2 INITIALIZING SETTING VALUES

To restart setting from the default state, initialization can be used. Refer to attached 17.3 PARAMETER LIST for the default values.

IMPORTANT

- Currently set parameters will be lost after an initialization. It is recommended to record the parameters before initialization.
- Even if the unit is shipped with the specified parameters with the option code '/SET'; such parameters will be lost after an initialization. Be careful that the initialization does not recover the ex-factory settings.

16.2.1 OPERATING PROCEDURE

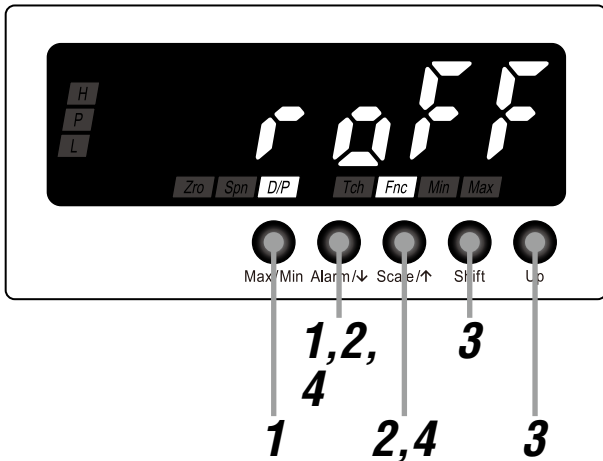

1 Hold down Max/Min and Alarm/↓ buttons at once for a preset time duration to move on to Lockout Setting Mode.

- The alarm setting lockout is indicated.
- 'D/P' and 'Fnc' indicators turn on.

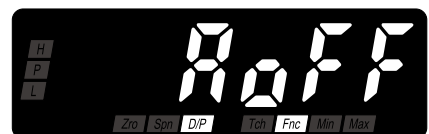

NOTE

'A OFF' or 'A ON' is indicated depending on the setting.

2 Press Alarm/↓ or Scale/↑ button to go to the initialization.

- 'ROFF' is indicated.
- 'D/P' and 'Fnc' indicators turn on.



3 Press Shift or Up button to select 'RST'.

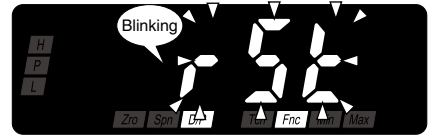

4 Press Alarm/↓ or Scale/↑ button to execute the initialization.

- The initialization will be completed in approx. 3 seconds and the display will return to Measuring Mode.

16.3 CONFIRMING FIRMWARE VERSION

The firmware version of the unit can be confirmed.

Confirm the version in the following cases:

- The display is different from the one described in the operating manual.
- The firmware version is necessary to consult us for troubles.

16.3.1 OPERATING PROCEDURE

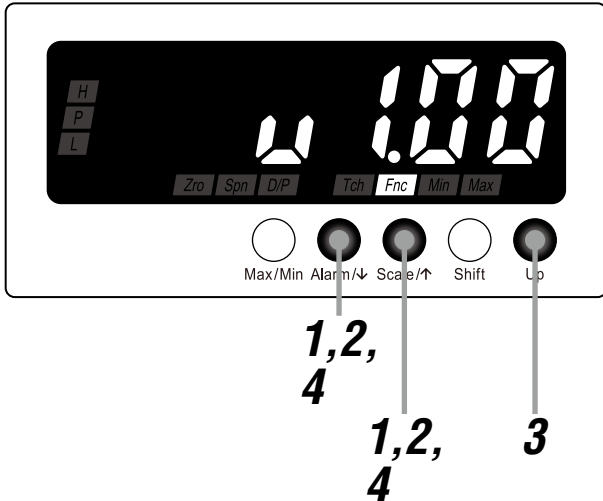

1 Hold down Alarm/↓ and Scale/↑ buttons at once for 3 seconds or more to move on to Advanced Setting Mode.

- The moving average sampling No. is indicated.
- 'Fnc' indicator turns on.

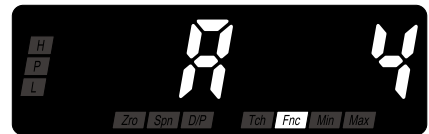

NOTE

'A OFF', 'A 2', 'A 4', 'A 8', 'A 16', 'A 32' or 'A 64' is indicated depending on the setting.

2 Press Alarm/↓ or Scale/↑ button to go to the version indication.

- The first half of the firmware version number is indicated.
- 'Fnc' indicator turns on.



3 Press Up button to indicate another 4 digits of the version number.



NOTE

- The above figures show the firmware version V1.00.0008.
- The displays depend on the firmware version number.

4 Hold down Alarm/↓ or Scale/↑ button for 3 seconds or more to return to Measuring Mode.

17. APPENDICES

17.1 SPECIFICATIONS

■ GENERAL SPECIFICATIONS

Construction		Panel mount type
Degree of protection		IP66; Applicable to the front of the panel meter mounted according to the specified panel cutout. Only screw mounting conforms.
Connection		Screwless spring terminal
Applicable wire size		0.2 to 0.5 mm ² , stripped length 6 mm
Housing material		Flame-resistant (gray)
Isolation		Input to alarm output to power
Setting (front button)	Scaling setting mode	Linearizer, input scaling ZERO/SPAN, display scaling ZERO/SPAN, decimal point position
	Alarm setting mode	Alarm point, H/L alarm setpoint, H/L trip action, H/L deadband (hysteresis), H/L trip delay, H/L coil at alarm, main display blinking at alarm
	Advanced setting mode	Moving average, low-end cutout, low-end cutout value, brightness, setting time out, transition time to Lockout Setting Mode, display refreshing rate, version indication
	Lockout setting mode	Alarm setting lockout, scaling setting lockout, advanced setting lockout, forced zero lockout, initialization
Averaging		None or moving average
Lockout setting		Prohibiting certain operations; protecting settings

■ DISPLAY

Display		16 mm (.63) high, 4 ½ digits, 7-segment LED
Display range		-19999 to 19999
Decimal point position		10 ⁻¹ , 10 ⁻² , 10 ⁻³ , 10 ⁻⁴ , or none
Zero indication		Higher-digit zeros are suppressed
Over-range indication		'-19999' or '19999' blinking for display values out of the display range 'S.ERR' and 'Min' or 'Max' blinking when the input signal is out of the usable range
Overload indication		'O.L.' and 'Max' blinking when input overload.
Alarm status indication	L indicator	Green turns on when the L alarm is tripped
	H indicator	Red turns on when the H alarm is tripped
	P indicator	Amber turns on when none of the other alarms is tripped Only 'P' turns on when no-alarm is selected with alarm setpoint
Function indicators		Zro, Spn, D/P, Tch, Fnc, Min, Max Display mode status and operation status, amber ON or blink

■ SUPPLY OUTPUT

Supply output (across the terminals 1 – 2)	Output voltage	24 – 28 V DC max. with no load 18 V DC min. at 20 mA no load	
	Current rating	≤ 22 mA DC	
	Shortcircuit protection	Current limited	35 mA max.
		Protected time duration	No limit

■ INPUT SPECIFICATIONS

DC current	Input resistance	250 Ω resistor incorporated
	Usable range	4.00 – 20.00 mA DC
	Conformance range	-20 – +120% of usable range

■ OUTPUT SPECIFICATIONS

Alarm output		Photo MOSFET relay
	Rating	26.4 V DC @ 100 mA (resistive load)
	ON resistance	$\leq 5 \Omega$

■ INSTALLATION

Power consumption	DC power	24 V DC	Operational voltage range 24 V DC $\pm 10\%$ Ripple 10% p-p max. 2.2 W max.
Operating temperature		-10 to +55°C (14 to 131°F)	
Operating humidity		10 to 90% RH (non-condensing)	
Mounting		Magnet or screw mounting	
Weight		85 g (3.0 oz)	

■ PERFORMANCE

Accuracy	$\pm 0.1\% \pm 1$ digit (input within 1 – 100% for square root extraction)
Temp. coefficient	$\pm 0.015\%/^{\circ}\text{C}$ ($\pm 0.008\%/^{\circ}\text{F}$)
Response time	≤ 0.5 sec. (alarm output: 0 – 100% at 90% setpoint)
Line voltage effect	$\pm 0.1\%$ over voltage range
Insulation resistance	$\geq 100 \text{ M}\Omega$ with 500 V DC
Dielectric strength	1500 V AC @ 1 minute (input to alarm output to power to ground)

■ STANDARDS & APPROVALS

EU conformity	EMC Directive EMI EN 61000-6-4 EMS EN 61000-6-2 RoHS Directive
---------------	---

17.2 MODEL NUMBERING

Code number: **47NLDY-[1]-R[2]**

INPUT

Current

4 – 20 mA DC (input resistance 250 Ω)

[1] DISPLAY COLOR

R: Red

YR: Orange

G: Green

B: Blue

W: White

POWER INPUT

DC Power

R: 24 V DC (operational voltage range 24 V \pm 10%, ripple 10% p-p max.)

[2] OPTIONS

Blank: None

/Q: With options (specify the specification)

■ SPECIFICATIONS OF OPTION: Q

EX-FACTORY SETTING

/SET: Preset according to the Ordering Information Sheet (No. ESU-9567)

17.3 PARAMETER LIST

MODE	PARAMETER	SETTING RANGE	INDICATOR	DISPLAY	DEFAULT VALUE	DECIMAL POINT POSITION	UNIT
Measuring	Present value	-19999 – 19999	[H], [P], [L]	----	----	*1	User-defined
	MAX value	-19999 – 19999	[Max]	----	----	*1	User-defined
	MIN value	-19999 – 19999	[Min]	----	----	*1	User-defined
	Forced zero	-19999 – 19999	[Zro], [Fnc]	----	----	*1	User-defined
	L alarm setpoint	-19999 – 19999	[L]	----	----	*1	User-defined
	H alarm setpoint	-19999 – 19999	[H]	----	----	*1	User-defined
Scaling setting	Linearizer	Linear, square root extraction	[DIP]	[Line], [Sqrt]	[Line]	----	----
	Input scaling ZERO	4.00 – 20.00	[Zro], [Tch]	[0400] to [2000]	[0400]	----	mA DC
	Display scaling ZERO	-19999 – 19999	[Zro], [DIP]	[19999] to [99999]	[0400]	*1	User-defined
	Input scaling SPAN	4.00 – 20.00	[Spn], [Tch]	[0400] to [2000]	[2000]	----	mA DC
	Display scaling SPAN	-19999 – 19999	[Spn], [DIP]	[19999] to [99999]	[2000]	*1	User-defined
	Decimal point position	No decimal point, or 10 ⁻¹ to 10 ⁻⁴	[DIP]	[0000], [0000], [0000], [0000]	[0000]	----	----
	Teach calibration (ZERO)	----	[Zro], [Tch]	----	----	----	----
	Teach calibration (SPAN)	----	[Spn], [Tch]	----	----	----	----
Alarm setting	Alarm point	Dual alarm	[H], [L], [Fnc]	[ALn2]	[ALn2]	----	----
		No alarm	[P], [Fnc]	[ALn0]			
	L alarm setpoint	-19999 – 19999	[L], [Fnc]	[19999] to [99999]	[0560]	*1	User-defined
	L trip action	High trip, low trip	[L], [Fnc]	[LnH], [LnLo]	[LnLo]	----	----
	L deadband (hysteresis)	0000 – 9999	[P], [L], [Fnc]	[0000] to [9999]	[0000]	----	User-defined
	L trip delay	00 – 99	[L], [DIP], [Fnc]	[00] to [99]	[00]	----	Second
	L coil at alarm	Coil energized at alarm, de-energized at alarm	[L], [Fnc]	[rYEn], [rYdn]	[rYEn]	----	----
	H alarm setpoint	-19999 – 19999	[H], [Fnc]	[19999] to [99999]	[1840]	*1	User-defined
	H trip action	High trip, low trip	[H], [Fnc]	[LnH], [LnLo]	[LnH]	----	----
	H deadband (hysteresis)	0000 – 9999	[H], [P], [Fnc]	[0000] to [9999]	[0000]	----	User-defined
	H trip delay	00 – 99	[H], [DIP], [Fnc]	[00] to [99]	[00]	----	Second
	H coil at alarm	Coil energized at alarm, de-energized at alarm	[H], [Fnc]	[rYEn], [rYdn]	[rYEn]	----	----
	Main display blinking at alarm	No blinking, blinking in 1.0, 0.5, 0.2, 0.1 sec. intervals	[Fnc]	[b 0], [b 1], [b 2], [b 3], [b 4]	[b 0]	----	Second

*1 Conforms to decimal point position setting.

NOTE 1: Indicators with the present value in Measuring Mode depend on the set alarm trip action.

NOTE 2: INDICATOR: = ON, [] = Blinking

MODE	PARAMETER	SETTING RANGE	INDICATOR	DISPLAY	DEFAULT VALUE	DECIMAL POINT POSITION	UNIT
Advanced setting	Moving average	None, 2, 4, 8, 16, 32, 64	[Fnc]	[R OFF] [R 2] [R 4] [R 8] [R 16] [R 32] [R 64]	[R 4]	----	Sample
	Low-end cutout	OFF, ON	[Fnc]	[d OFF] [d on]	[d OFF]	----	----
	Low-end cutout value	00.0 – 99.9	[Zro], [Fnc]	[d 000] to [d 999]	[d 000]	----	%
	Brightness	1 (dark) to 5 (bright)	[DIP], [Fnc]	[L 1] [L 2] [L 3] [L 4] [L 5]	[L 3]	----	----
	Setting time out	00 (setting time out disabled) 01 – 99	[DIP], [Fnc]	[r 00] to [r 99]	[r 60]	----	Second
	Transition time to Lockout Setting Mode	00 – 99	[DIP], [Fnc]	[P 00] to [P 99]	[P 05]	----	Second
	Display refreshing rate	00.0 – 99.9	[Fnc]	[F 000] to [F 999]	[F 000]	----	Second
	Version indication	----	[Fnc]	----	----	----	----
Lockout setting	Alarm setting lockout	OFF, ON	[DIP], [Fnc]	[R OFF] [R on]	[R OFF]	----	----
	Scaling setting lockout	OFF, ON	[DIP], [Fnc]	[S OFF] [S on]	[S OFF]	----	----
	Advanced setting lockout	OFF, ON	[DIP], [Fnc]	[d OFF] [d on]	[d OFF]	----	----
	Forced zero lockout	OFF, ON	[DIP], [Fnc]	[z OFF] [z on]	[z on]	----	----
	Initialization	OFF, initialization	[DIP], [Fnc]	[r OFF] [r 5k]	[r OFF]	----	----

NOTE 2: INDICATOR: = ON, = Blinking

17.4 PARAMETER MAP

17.4.1 OPERATION IN MEASURING MODE

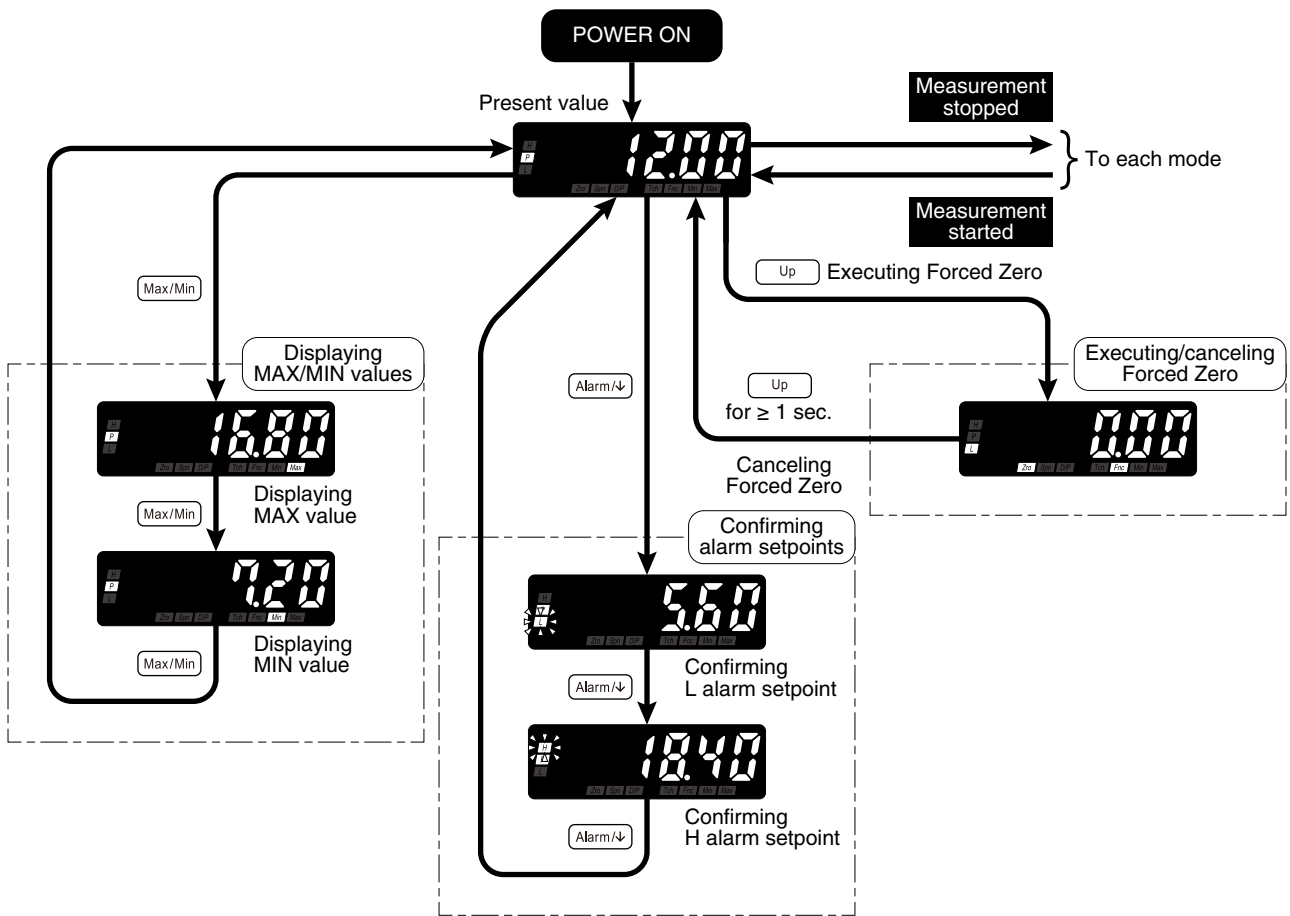

NOTE

- The display depends on the settings and input.
- When "No alarm" is selected for the alarm point parameter, alarm setpoints cannot be confirmed.
- Forced zero cannot be executed or canceled when the operation is disabled with the forced zero lockout setting.

17.4.2 SCALING SETTING MODE

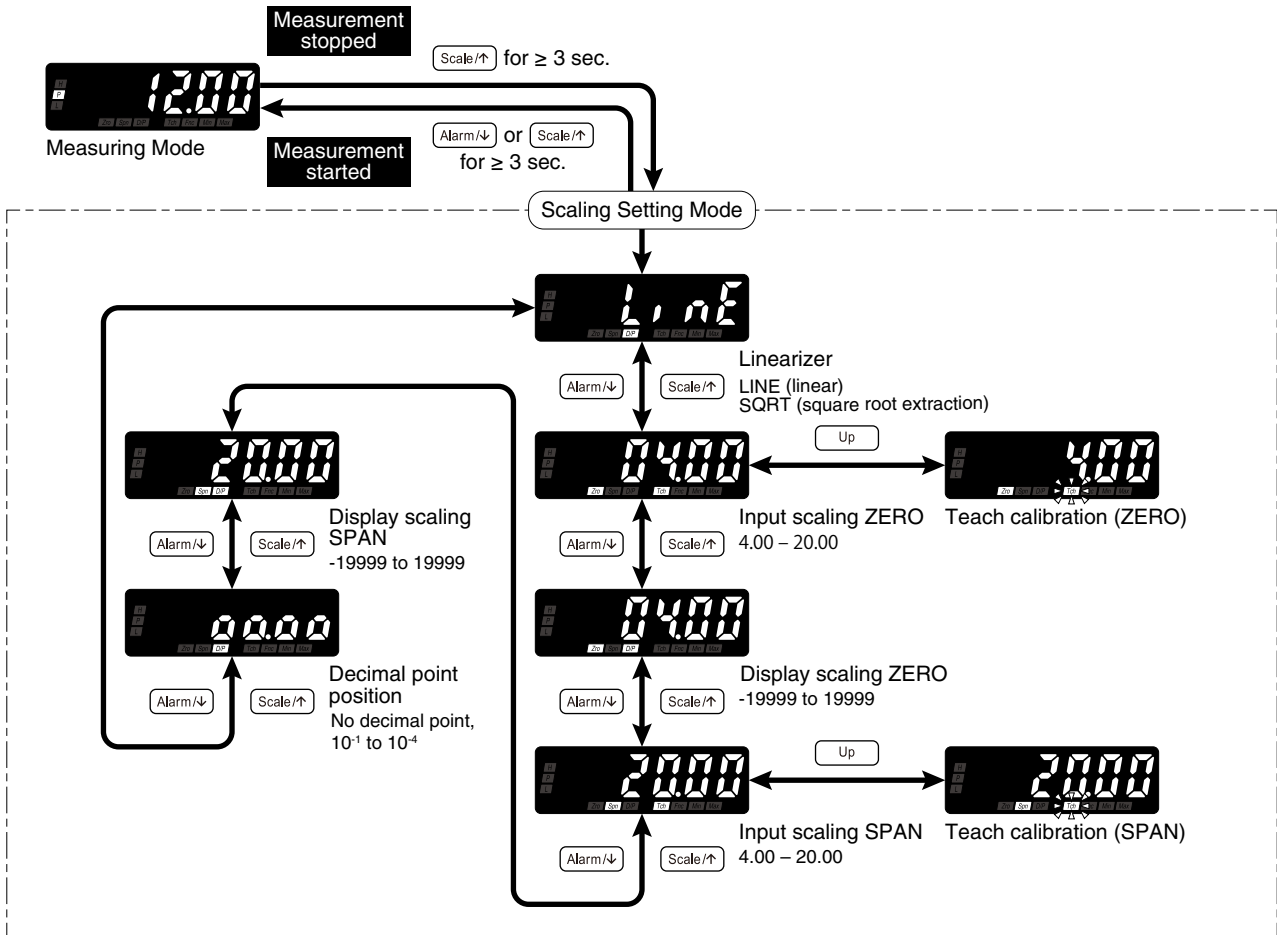

NOTE

The display depends on the settings and input.

17.4.3 ALARM SETTING MODE

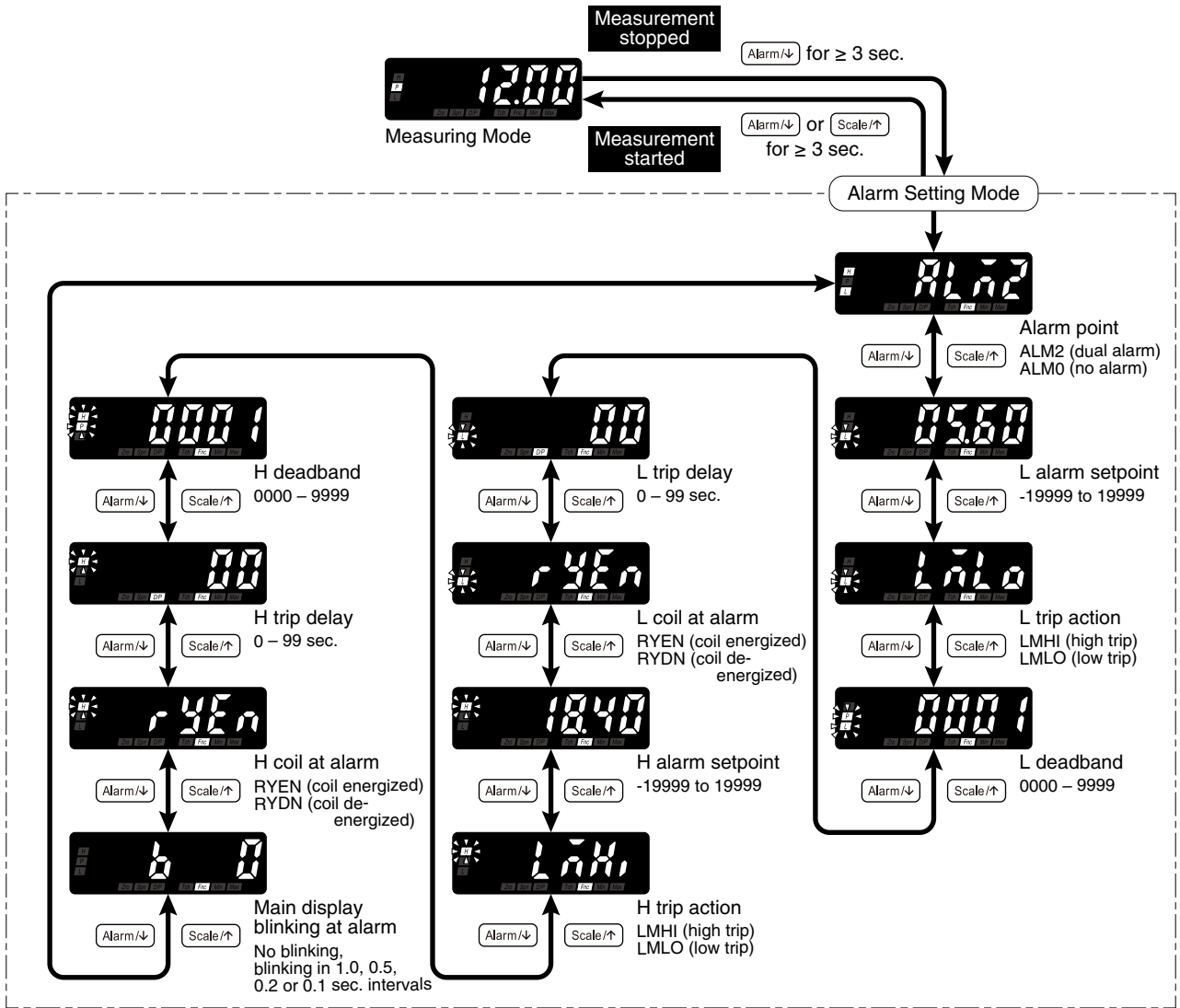

NOTE

- The display depends on the settings and input.
- Alarm Setting Mode is locked when "No alarm" is selected for the alarm point parameter.

17.4.4 ADVANCED SETTING MODE

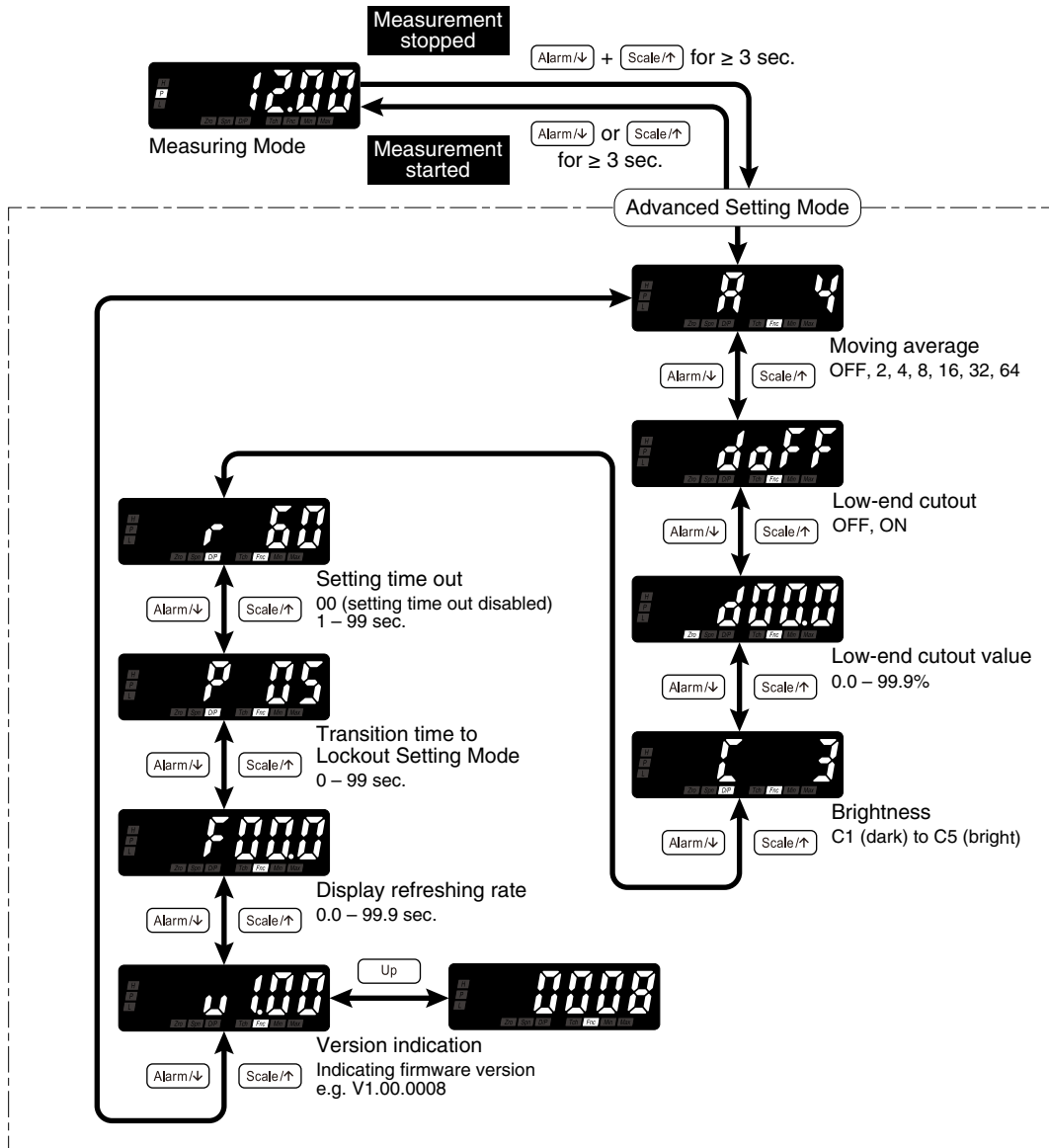

NOTE

- The display depends on the settings and input.
- With the low-end cutout set to OFF, the low-end cutout value setting is locked.
- Version indication is for indication only, not for setting.

17.4.5 LOCKOUT SETTING MODE

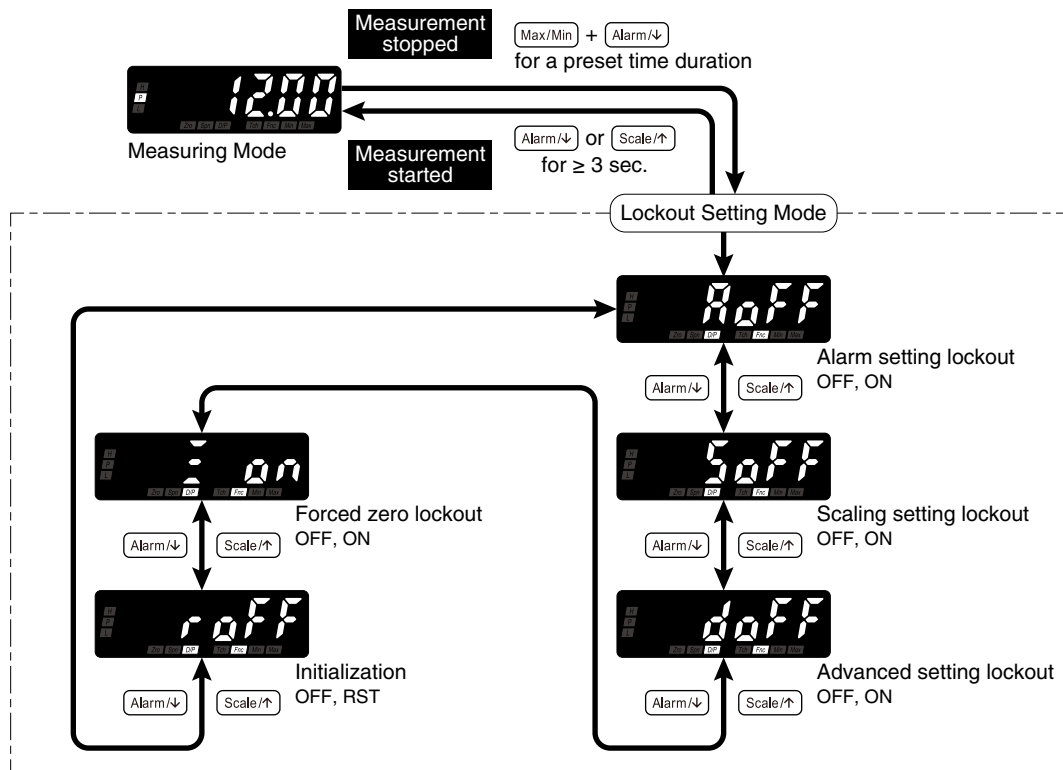













NOTE

The display depends on the settings and input.





















17.5 CHARACTER SET

■ NUMERALS AND NEGATIVE SIGN

0	1	2	3	4	5	6	7	8	9
									
-	-1*1								
									

*1 Indication when the fifth digit is '-1'.

■ ALPHABET

A	B	C	D	E	F	G	H	I	J
									
K	L	M	N	O	P	Q	R	S	T
									
U	V	W	X	Y	Z				
