

Digital Panel Meters 47 Series

STRAIN GAUGE INPUT DIGITAL PANEL METER

(4½ digit, LED display type)

Functions & Features

- 4½ digit strain gauge input digital panel meter
- 1/8 DIN size
- Moving average function to suppress the display flickering
- Scaling, tare adjustment, low-end cutout
- Max. and Min. value display
- Safety terminal cover tethered to the device with a strap
- IP66 front panel
- Separable terminal block

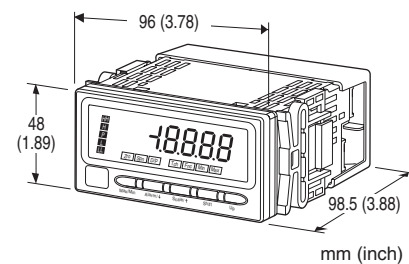

MODEL: 47LLC-[1][2][3][4]-[5][6]

ORDERING INFORMATION

- Code number: 47LLC-[1][2][3][4]-[5][6]
- Specify a code from below for each [1] through [6]. (e.g. 47LLC-S101G-M2/Q)
- Specify the specification for option code /Q (e.g. /C01/S01/SET)

[1] INPUT STRAIN GAUGE

- S1:** 0.0 - 1.0 mV/V
S2: 0.0 - 3.0 mV/V
S3: 0.0 - 10.0 mV/V
S4: 0.0 - 30.0 mV/V

[2] DC OUTPUT

0: Without

Current

- A:** 4 - 20 mA DC (Load resistance 550 Ω max.)
D: 0 - 20 mA DC (Load resistance 550 Ω max.)

Voltage

- 4:** 0 - 10 V DC (Load resistance 10 kΩ min.)
5: 0 - 5 V DC (Load resistance 5000 Ω min.)
6: 1 - 5 V DC (Load resistance 5000 Ω min.)
4W: -10 - +10 V DC (Load resistance 10 kΩ min.)

[3] ALARM OUTPUT

- 0:** None
1: N.O. relay contact, 4 points
2: SPDT relay contact, 2 points
3: Photo MOSFET relay, N.O., 4 points

[4] DISPLAY COLOR

- R:** Red
YR: Orange
G: Green
BG: Bluegreen
B: Blue
W: White

[5] POWER INPUT

AC Power

M2: 100 - 240 V AC (Operational voltage range 85 - 264 V, 50/60 Hz)

DC Power

- R:** 24 V DC
 (Operational voltage range 24 V ±10 %, ripple 10 %p-p max.)
P: 110 V DC
 (Operational voltage range 85 - 150 V, ripple 10 %p-p max.)

[6] OPTIONS

- blank:** none
/Q: With options (specify the specification)

SPECIFICATIONS OF OPTION: Q (multiple selections)

COATING (For the detail, refer to M-System's web site.)

Moving parts and indicators are not coated.

- /C01:** Silicone coating
/C02: Polyurethane coating
/C03: Rubber coating

TERMINAL SCREW MATERIAL

/S01: Stainless steel

EX-FACTORY SETTING

/SET: Preset according to the Ordering Information Sheet (No. ESU-9505)

GENERAL SPECIFICATIONS

Construction: Panel flush mounting

Degree of protection: IP66; applicable to the front of the panel meter mounted according to the specified panel cutout

Connection: M3 screw terminals (torque 0.6 N·m)

Screw terminal: Nickel-plated steel (standard) or stainless steel

Housing material: Flame-resistant resin (gray)

Isolation: Strain gauge input or excitation or contact input or SG to DC output to HH output or H output to L output or LL

output to power

Excitation: 2.5 V, 5 V, 7.5 V or 10 V selectable (front)

Tare adjustment: Via the front button control or by the external contact input

Setting: (Front button)

- Scaled range
- Alarm setpoint
- Hysteresis (deadband)
- Moving average
- Others

(Refer to the instruction manual for details)

Read rate: 40 times/sec. (25 msec.)

Averaging: None or moving average

Lockout Setting: Prohibiting certain operations; protecting settings

DISPLAY

Display: 16 mm (.63) high, 4 ½ digits, LED

Display range: -19999 to 19999

Decimal point position: 10⁻¹, 10⁻², 10⁻³, 10⁻⁴ or none

Zero indication: Higher-digit zeros are suppressed.

Over-range indication: '-19999' or '19999' blinking for display values out of the scaled range.

'S.ERR' and 'Min' or 'Max' blinking when the input signal is out of the usable range.

Alarm status indication

LL indicator: Turns on when the LL alarm is tripped.

L indicator: Turns on when the L alarm is tripped.

H indicator: Turns on when the H alarm is tripped.

HH indicator: Turns on when the HH alarm is tripped.

P indicator: Turns on when none of the other alarms is tripped.

Only 'P' turns on with no-alarm-output type. 'LL' or 'HH' does not turn on with dual-alarm-output type.

All setpoints can be independently set either for Hi or Lo alarm trip.

Engineering unit indication: Sticker label attached

DC, AC, mV, V, kV, μA, mA, A, kA, mW, W, kW, var, kvar, Mvar, VA, Hz, Ω, kΩ, MΩ, cm, mm, m, m/sec, mm/min, cm/min, m/min, m/h, m/s², inch, l, l/s, l/min, l/h, m³, m³/sec, m³/min, m³/h, Nm³/h, N·m, N/m², g, kg, kg/h, N, kN, Pa, kPa, MPa, t, t/h, °C, °F, %RH, J, kJ, MJ, rpm, sec, min, pH, %, ppm, etc.

INPUT SPECIFICATIONS

■ **Strain Gauge Input**

- **Strain Gauge:** Refer to the next table
- **Excitation:** 2.5 V, 5 V, 7.5 V or 10 V selectable

Maximum current: 120 mA

Load resistance: ≥ 85 Ω

Default setting: 2.5 V

■ **Tare Command Input:** TTL level (5V-CMOS level), open collector or dry contact

(saturation voltage ≤ 1 V, sink current 0.5 mA)

TYPE	STRAIN GAUGE RATING	ZERO ADJUSTMENT
S1	0.0 – 1.0mV/V	-10.00 – +10.00mV
S2	0.0 – 3.0mV/V	-30.00 – +30.00mV
S3	0.0 – 10.0mV/V	-100.0 – +100.0mV
S4	0.0 – 30.0mV/V	-300.0 – +300.0mV

TYPE	SPAN	INPUT VOLTAGE
S1	1.00 – 10.00mV	-10.00 – +20.00mV
S2	3.00 – 30.00mV	-30.00 – +60.00mV
S3	10.0 – 100.0mV	-100.0 – +200.0mV
S4	30.0 – 300.0mV	-300.0 – +600.0mV

Note: Choose Type S2 for the strain gauge rating 2.0mV/V with the excitation voltage 10V.

For detailed information, refer to "Input Scaling Values A/B v.s. Tare Adjustment" under "PARAMETER LIST" on the instruction manual.

OUTPUT SPECIFICATIONS

■ **DC Current**

Operational range: -5 – +105 %

■ **DC Voltage**

Operational range: -5 – +105 %

■ **Alarm Output:** Relay contact

Rated load: 250 V AC @ 3 A (cos φ = 1)

30 V DC @ 3 A (resistive load)

Maximum switching voltage: 250 V AC, 30 V DC

Maximum switching power: 750 VA, 90 W (resistive load)

Minimum load: 5 V DC @ 10 mA

Mechanical life: ≥ 5 × 10⁶ cycles (rate 180 cycles/min.)

■ **Alarm Output: Photo MOSFET Relay**

Rating: 120 V AC/DC @ 80 mA (resistive load)

ON resistance: ≤ 30 Ω

Permissible: 250 mW

INSTALLATION

Power consumption

• **AC:**

Approx. 9 VA at 100 V

Approx. 12 VA at 200 V

Approx. 13 VA at 264 V

• **DC:** Approx. 5 W

Operating temperature: -10 to +55°C (14 to 131°F)

Operating humidity: 30 to 90 %RH (non-condensing)

Mounting: Panel flush mounting

Weight: 300 g (0.66 lbs)

PERFORMANCE in percentage of max. span

Accuracy

Display: ±0.1 % ±1 digit

Output: $\pm 0.25\%$ (DC output = display + output)
Temp. coefficient: $\pm 0.015\%/^{\circ}\text{C}$ ($\pm 0.008\%/^{\circ}\text{F}$)
Input resolution: Max. 20 bits
Output resolution: Max. 16 bits
Response time: ≤ 0.5 sec.
 (alarm output: 0 - 100 % at 90 % setpoint)
 ≤ 0.5 sec. (DC output: 0 - 90 %)
Excitation: Set value ± 250 mV
Line voltage effect: $\pm 0.1\%$ over voltage range
Insulation resistance: $\geq 100\text{ M}\Omega$ with 500 V DC
Dielectric strength: 2000 V AC @ 1 minute (strain gauge
 input or excitation or contact input or SG to DC output to HH
 output or H output to L output or LL output to power to
 ground)

EXTERNAL VIEW

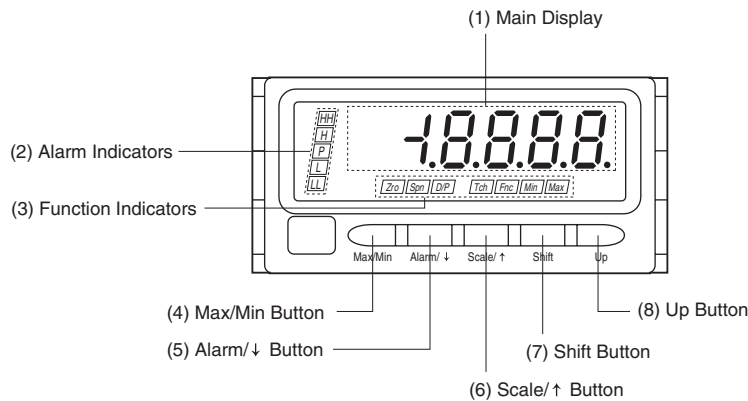

• COMPONENT IDENTIFICATION

No.	COMPONENT	FUNCTION
(1)	Main display	Indicates present values and setting values.
(2)	Alarm indicators *1	Indicate alarm status of the input signal.
(3)	Function indicators	Indicate the device status.
(4)	Max/Min button	Used to switch the main display to show the present values, maximum values or minimum values.
(5)	Alarm/↓ button	Used to confirm the alarm setpoints; to move on to the alarm setpoint and other setting modes; or to shift through setting items in each setting mode.
(6)	Scale/↑ button	Used to move on to the scaling and other setting modes; or to shift through setting items in each setting mode.
(7)	Shift button	Used to move on to the setting standby status and shift through display digits in each setting item.
(8)	Up button	Used to select setting values.

*1. Only the 'P' indicator turns on with 'no alarm output' option. For dual alarm type, 'LL' or 'HH' does not turn on.

EXTERNAL DIMENSIONS & TERMINAL ASSIGNMENTS unit: mm (inch)

■ TOP VIEW

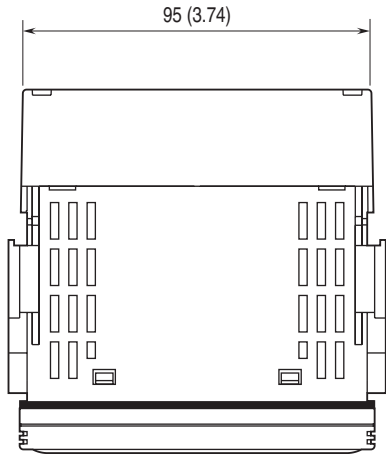

■ FRONT VIEW

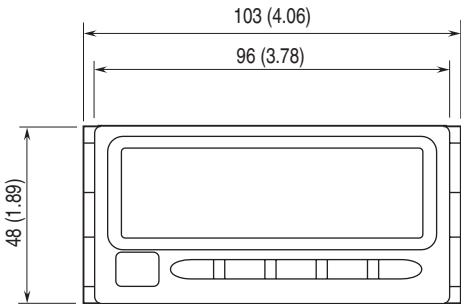

■ SIDE VIEW

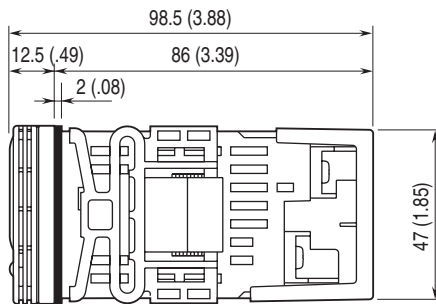

■ REAR VIEW

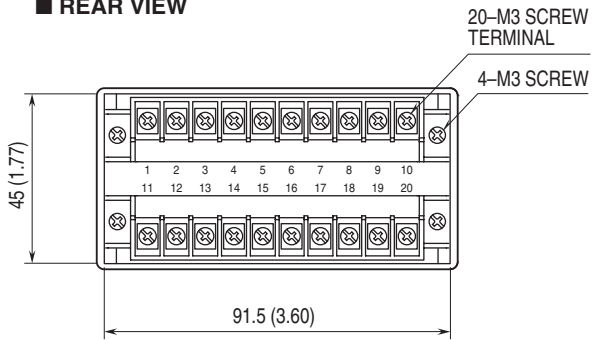

MOUNTING REQUIREMENTS unit: mm

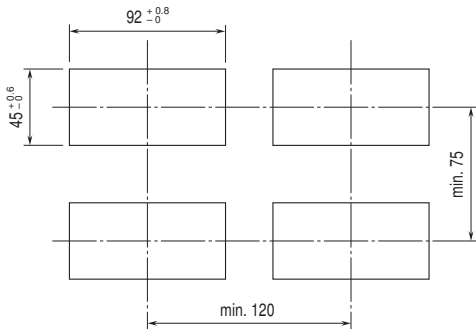

Panel thickness: 1.6 to 8.0 mm

SCHEMATIC CIRCUITRY & CONNECTION DIAGRAM

■ No alarm output

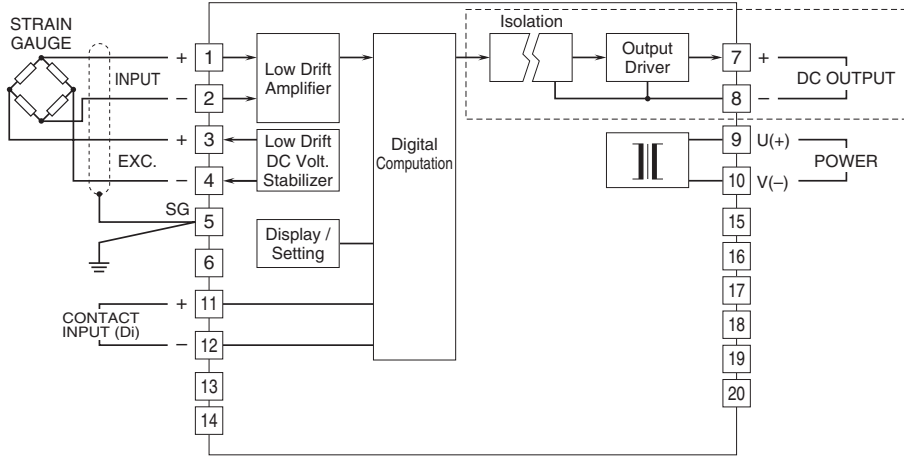

■ N.O. Contact, 4 points / Photo MOSFET relay, 4 points

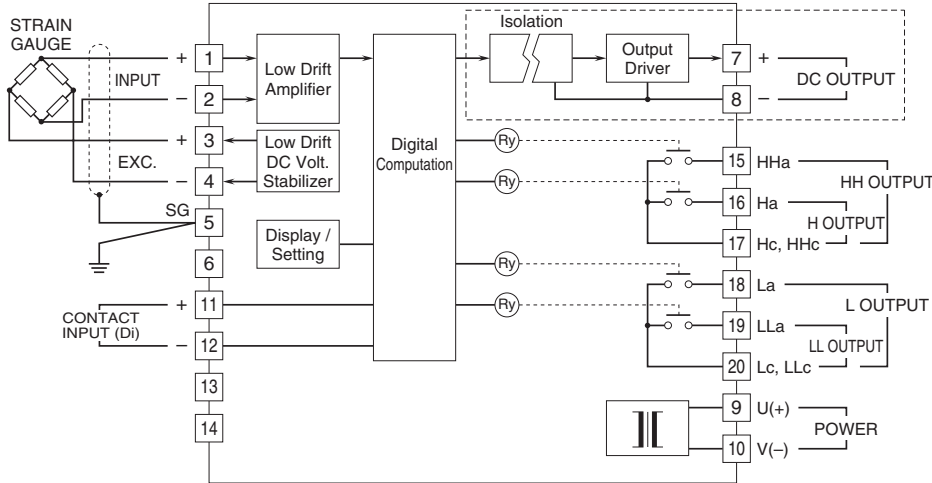

■ SPDT contact, 2 points

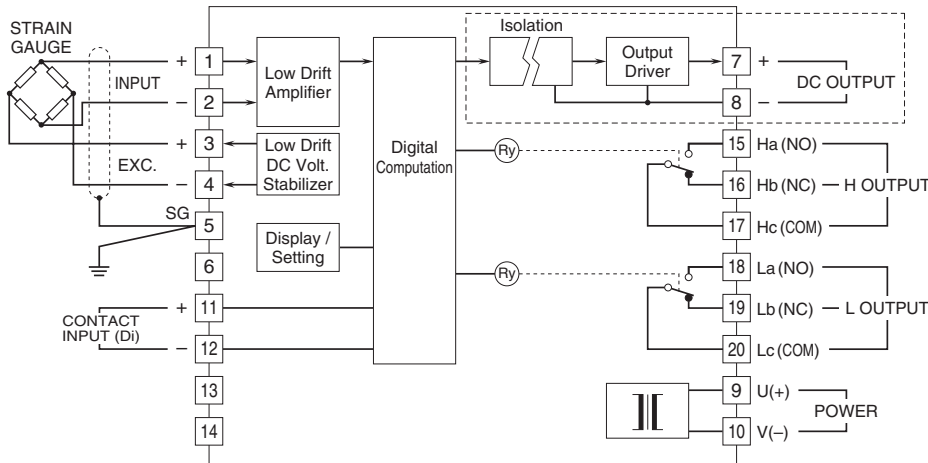

Note: The section enclosed by broken line is only with DC output option.

■ Relay Protection

• AC Powered

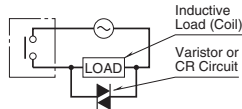

• DC Powered

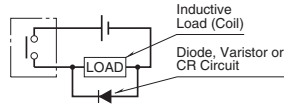



Specifications are subject to change without notice.