

Digital Panel Meters 47 Series

FREQUENCY INPUT DIGITAL PANEL METER

(4½ digit, LED display type)

Functions & Features

- 4½ digit digital panel meter
- Measures line frequency deviation of a heavycurrent power system
- 1/8 DIN size
- Max. and Min. value display
- IP66 front panel
- Separable terminal block
- Rear terminal cover for safety strapped to the meter

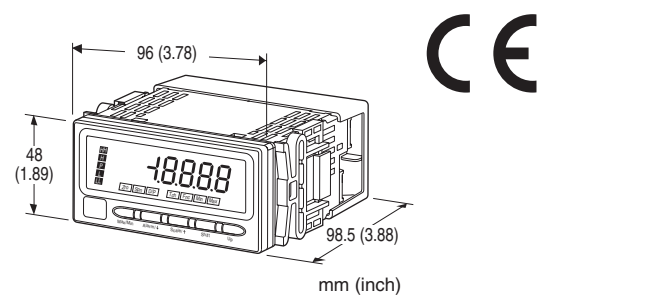

MODEL: 47LHZ-1[1][2][3]-[4][5]

ORDERING INFORMATION

- Code number: 47LHZ-1[1][2][3]-[4][5]
- Specify a code from below for each [1] through [5]. (e.g. 47LHZ-101G-M2/Q)
- Specify the specification for option code /Q (e.g. /C01/S01/SET)

INPUT

1: Frequency input

[1] DC OUTPUT

0: Without

Current

A: 4 - 20 mA DC (Load resistance 550 Ω max.)

D: 0 - 20 mA DC (Load resistance 550 Ω max.)

Voltage

4: 0 - 10 V DC (Load resistance 10 kΩ min.)

5: 0 - 5 V DC (Load resistance 5000 Ω min.)

6: 1 - 5 V DC (Load resistance 5000 Ω min.)

4W: -10 - +10 V DC (Load resistance 10 kΩ min.)

[2] ALARM OUTPUT

0: None

1: N.O. relay contact, 4 points

2: SPDT relay contact, 2 points

[3] DISPLAY COLOR

R: Red

YR: Orange

G: Green

BG: Bluegreen

B: Blue

W: White

[4] POWER INPUT

AC Power

M2: 100 - 240 V AC (Operational voltage range 85 - 264 V, 50/60 Hz)

DC Power

R: 24 V DC

(Operational voltage range 24 V ±10 %, ripple 10 %p-p max.)

P: 110 V DC

(Operational voltage range 85 - 150 V, ripple 10 %p-p max.)

[5] OPTIONS

blank: none

/Q: With options (specify the specification)

SPECIFICATIONS OF OPTION: Q (multiple selections)

COATING (For the detail, refer to M-System's web site.)

Moving parts and indicators are not coated.

/C01: Silicone coating

/C02: Polyurethane coating

/C03: Rubber coating

TERMINAL SCREW MATERIAL

/S01: Stainless steel

EX-FACTORY SETTING

/SET: Preset according to the Ordering Information Sheet

(No. ESU-9517)

GENERAL SPECIFICATIONS

Construction: Panel flush mounting

Degree of protection: IP66; applicable to the front of the panel meter mounted according to the specified panel cutout

Connection: M3 screw terminals (torque 0.6 N·m)

Screw terminal: Nickel-plated steel (standard) or stainless steel

Housing material: Flame-resistant resin (gray)

Isolation: Input to DC output to HH output or H output to L output or LL output to power

Input waveform: Up to 15 % of 3rd harmonic content

Setting: (Front button)

- Scaled range
- Input type

- Alarm setpoint
- Hysteresis (deadband)
- Others

(Refer to the instruction manual for details)

Lockout Setting: Prohibiting certain operations; protecting settings

DISPLAY

Display: 16 mm (.63) high, 4 ½ digits, LED

Display range: -19999 to 19999

Decimal point position: 10⁻¹, 10⁻², 10⁻³, 10⁻⁴ or none

Zero indication: Higher-digit zeros are suppressed.

Over-range indication: '19999' or '19999' blinking for display values out of the scaled range.

'S.ERR' and 'Min' or 'Max' blinking when the input signal is out of the usable range.

Alarm status indication

LL indicator: Turns on when the LL alarm is tripped.

L indicator: Turns on when the L alarm is tripped.

H indicator: Turns on when the H alarm is tripped.

HH indicator: Turns on when the HH alarm is tripped.

P indicator: Turns on when none of the other alarms is tripped.

Note: Only 'P' turns on with no-alarm-output type. 'LL' or 'HH' does not turn on with dual-alarm-output type.

All setpoints can be independently set either for Hi or Lo alarm trip.

Engineering unit indication: Sticker label attached

DC, AC, mV, V, kV, μA, mA, A, kA, mW, W, kW, var, kvar, Mvar, VA, Hz, Ω, kΩ, MΩ, cm, mm, m, m/sec, mm/min, cm/min, m/min, m/h, m/s², inch, l, l/s, l/min, l/h, m³, m³/sec, m³/min, m³/h, Nm³/h, N·m, N/m², g, kg, kg/h, N, kN, Pa, kPa, MPa, t, t/h, °C, °F, %RH, J, kJ, MJ, rpm, sec, min, pH, %, ppm, etc.

INPUT SPECIFICATIONS

Input voltage: Max. 300 V (conformance range 50 - 300 V)

Overload capacity: 450 V for 10 seconds, 360 V continuous

Default measuring range: 45 - 65 Hz

TYPE IND	MEASURING RANGE	OPERATIONAL RANGE	INPUT BURDEN
H50	45 - 55 Hz	40 - 60 Hz	≤0.5VA
H60	55 - 65 Hz	50 - 70 Hz	≤0.5VA
H55	45 - 65 Hz	40 - 70 Hz	≤0.5VA
H400	350 - 450 Hz	300 - 500 Hz	≤0.5VA
HF	10 - 500 Hz	5 - 600 Hz	≤0.5VA

OUTPUT SPECIFICATIONS

■ DC Current

Operational range: -5 - +105 %

■ DC Voltage

Operational range: -5 - +105 %

■ Alarm Output: Relay contact

Rated load: 250 V AC @ 3 A (cos φ = 1)

30 V DC @ 3 A (resistive load)

Maximum switching voltage: 250 V AC, 30 V DC

Maximum switching power: 750 VA, 90 W (resistive load)

Minimum load: 5 V DC @ 10 mA

Mechanical life: ≥ 5 × 10⁶ cycles (rate 180 cycles/min.)

INSTALLATION

Power consumption

•AC: Approx. 6.5VA

•DC: Approx. 3 W

Operating temperature: -10 to +55°C (14 to 131°F)

Operating humidity: 30 to 90 %RH (non-condensing)

Mounting: Panel flush mounting

Weight: 300 g (0.66 lbs)

PERFORMANCE in percentage of max. span

Accuracy

Display: ±0.1 Hz; ±1 Hz at 70 Hz or more (input 50 - 300 V)

Output: ±0.1 % (DC output = display + output)

Temp. coefficient: ±0.015 %/°C (±0.008 %/°F)

Input resolution: Max. 0.01 Hz

Output resolution: Max. 14 bits

Response time: ≤0.5 second except for 45 Hz or less

(alarm output: 0 - 100 % at 90 % setpoint)

≤0.5 second except for 45 Hz or less

(DC output: 0 - 90 %)

Line voltage effect: ±0.1 % over voltage range

Insulation resistance: ≥ 100 MΩ with 500 V DC

Dielectric strength: 2000 V AC @ 1 minute (input to DC output to HH output or H output to L output or LL output to power to ground)

STANDARDS & APPROVALS

CE conformity:

EMC Directive (2004/108/EC)

EMI EN 61000-6-4: 2007

EMS EN 61000-6-2: 2005

Low Voltage Directive (2006/95/EC)

EN 61010-1: 2001

Measurement Category III (input)

Measurement Category II (alarm output)

Installation Category II (power supply)

Pollution Degree 2

Input to alarm output to power: Reinforced insulation (300 V)

Input to DC output: Basic insulation (300 V)

Protection against access to the terminal blocks:

Finger protection (VDE 0660-514)

EXTERNAL VIEW

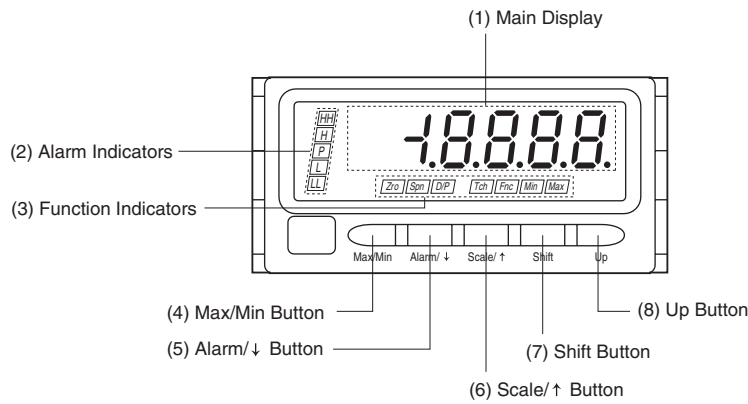

• COMPONENT IDENTIFICATION

No.	COMPONENT	FUNCTION
(1)	Main display	Indicates present values, setting values.
(2)	Alarm indicators	Indicate alarm status of the input signal.
(3)	Function indicators	Indicate setting modes and status.
(4)	Max/Min button	Used to switch the main display to show present values, maximum values or minimum values.
(5)	Alarm/↓ button	Used to move on to the alarm setting mode; or to shift through setting items in each setting mode.
(6)	Scale/↑ button	Used to move on to the scaling setting mode; or to shift through setting items in each setting mode.
(7)	Shift button	Used to move on to the setting standby status and shift through display digits in each setting item.
(8)	Up button	Used to select setting values.

Refer to the instruction manual for details on each function.

EXTERNAL DIMENSIONS & TERMINAL ASSIGNMENTS unit: mm (inch)

■ TOP VIEW

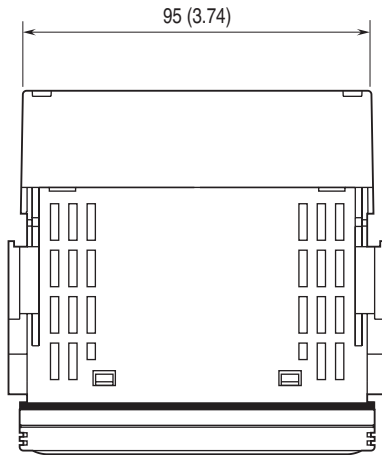

■ FRONT VIEW

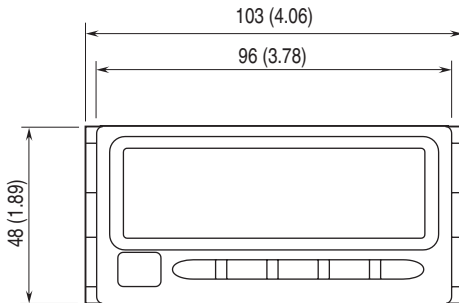

■ SIDE VIEW

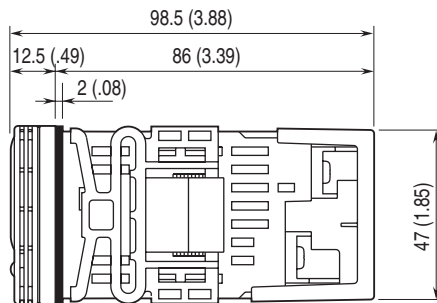

■ REAR VIEW

• No Alarm Output

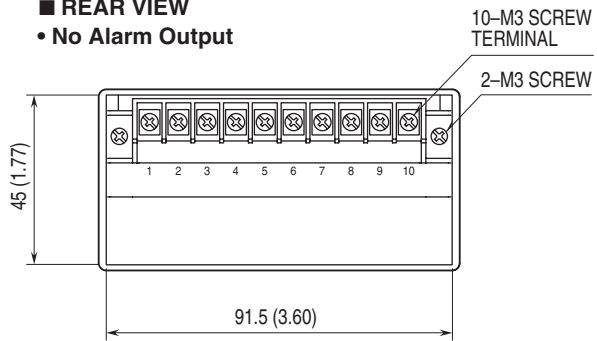

• Alarm Output

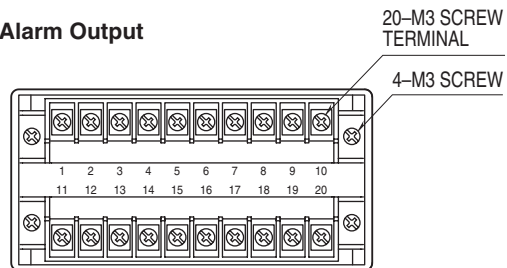

MOUNTING REQUIREMENTS unit: mm

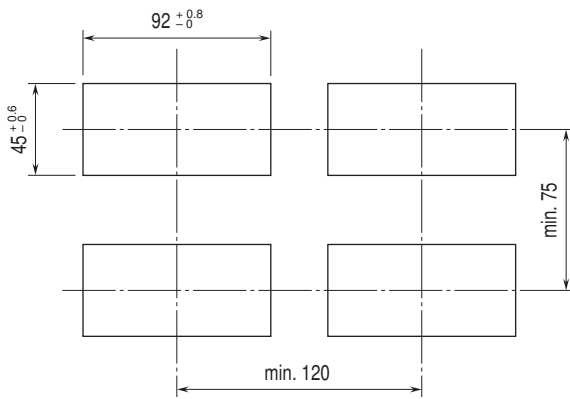

Panel thickness: 1.6 to 8.0 mm

SCHEMATIC CIRCUITRY & CONNECTION DIAGRAM

■ **ALARM SUFFIX CODE 0: No alarm output**

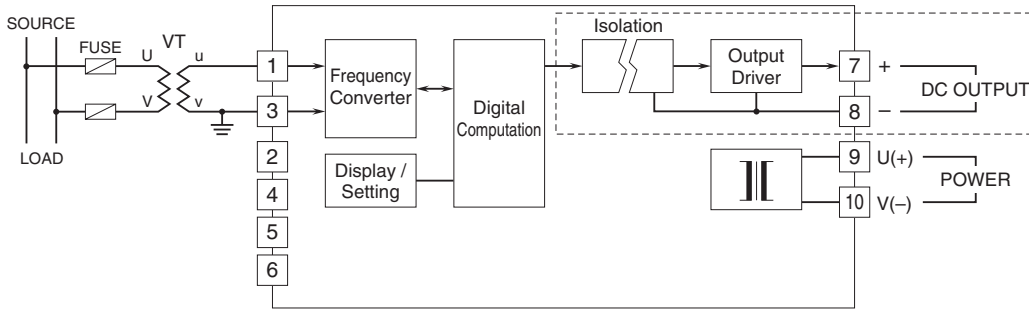

■ **ALARM SUFFIX CODE 1: N.O. contact, 4 points**

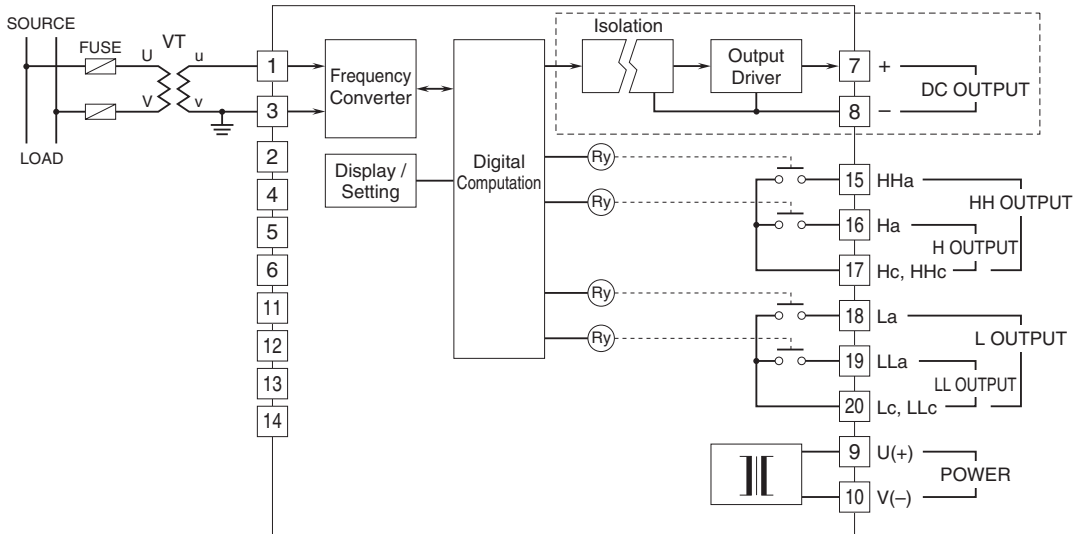

■ **ALARM SUFFIX CODE 2: SPDT contact, 2 points**

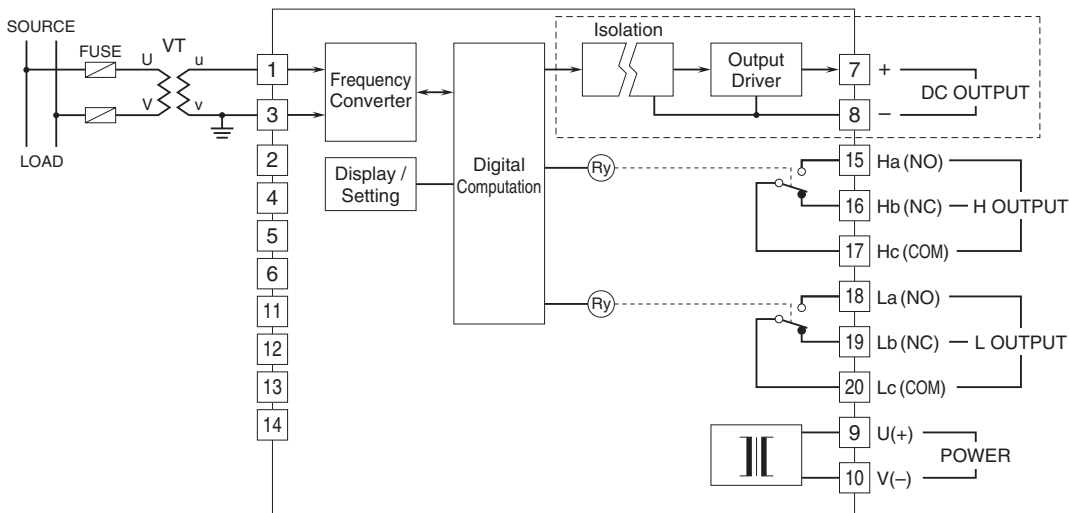

Note: The section enclosed by broken line is only with DC output option.

■ **Relay Protection**
• AC Powered

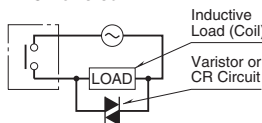

• DC Powered

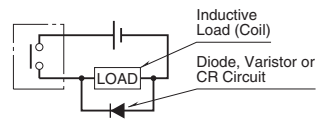



Specifications are subject to change without notice.