

# DC INPUT DIGITAL PANEL METER

(4 1/2 digit, LED display type)

MODEL **47LV**

## BEFORE USE ....

Thank you for choosing us. Before use, please check contents of the package you received as outlined below.

If you have any problems or questions with the product, please contact our sales office or representatives.

### ■ PACKAGE INCLUDES:

Digital panel meter  
(body + mounting bracket × 2 + watertight packing).....(1)  
Engineering unit sticker label sheet.....(1)

### ■ MODEL NO.

Confirm Model No. marking on the product to be exactly what you ordered.

### ■ INSTRUCTION MANUAL

This manual describes necessary points of caution when you use this product, including installation, connection and basic maintenance procedures.

For detailed explanations to operate and program the module, please refer to Model 47LV Operating Manual (EM-9502-B), downloadable at our web site.

2.00 marked parameters are usable with the product version 2.00 or higher.

## POINTS OF CAUTION

### ■ CONFORMITY WITH EU DIRECTIVES

- This equipment is suitable for Pollution Degree 2, Measurement category II (alarm output, transient voltage 2500V) and Installation Category II (transient voltage 2500V). Reinforced insulation (input or DC output to alarm output to power: 300V) and basic insulation (input to DC output: 300V) are maintained. Prior to installation, check that the insulation class of this unit satisfies the system requirements.
- Altitude up to 2000 meters.
- The equipment must be installed such that appropriate clearance and creepage distances are maintained to conform to CE requirements. Failure to observe these requirements may invalidate the CE conformance.
- The actual installation environments such as panel configurations, connected devices, connected wires, may affect the protection level of this unit when it is integrated in a panel system. The user may have to review the CE requirements in regard to the whole system and employ additional protective measures to ensure the CE conformity.
- In order to enable the operator to turn off the power input immediately, install a switch or a circuit breaker according to the relevant requirements in IEC 60947-2 and properly indicate it.

### ■ POWER INPUT RATING & OPERATIONAL RANGE

- Locate the power input rating marked on the product and confirm its operational range as indicated below:  
100 – 240V AC rating: 85 – 264V, 50/60 Hz, approx. 6.5VA  
24V DC rating: 24V ±10%, approx. 3W  
110V DC rating: 85 – 150V, approx. 3W

### ■ GENERAL PRECAUTIONS

- Before you remove the unit or mount it, turn off the power supply and input signal for safety.
- Be sure to put the terminal cover on while the power is supplied.

### ■ ENVIRONMENT

- Indoor use.
- When heavy dust or metal particles are present in the air, install the unit inside proper housing with sufficient ventilation.
- Do not install the unit where it is subjected to continuous vibration. Do not subject the unit to physical impact.
- Environmental temperature must be within -10 to +55°C (14 to 131°F) with relative humidity within 30 to 90% RH in order to ensure adequate life span and operation.
- Be sure that the ventilation slits are not covered with cables, etc.

### ■ REQUIREMENTS TO ENSURE IP66

- Observe the designated panel cutout size (W92 × H45 mm).
- The watertight packing included in the product package must be placed behind the front cover.
- Both mounting brackets must be fastened tightly until they hit the panel.
- Confirm visually that the packing is not contorted or excessively run off the edge after installation.

### ■ WIRING

- Make sure for safety that only qualified personnel perform the wiring.
- Do not install cables close to noise sources (high frequency line, etc.).
- Do not bind these cables together with those in which noises are present. Do not install them in the same duct.

### ■ EX-FACTORY SETTING (/SET)

- Activating “initialization” of Lockout Setting Mode, Ex-factory settings or user’s specified parameters will be deleted and overwritten with the factory default values. Notice that after this, Ex-factory settings will be irrecoverable.

### ■ AND ....

- The unit is designed to function as soon as power is supplied, however, a warm up for 10 minutes is required for satisfying complete performance described in the data sheet.

## COMPONENT IDENTIFICATION

### TOP VIEW

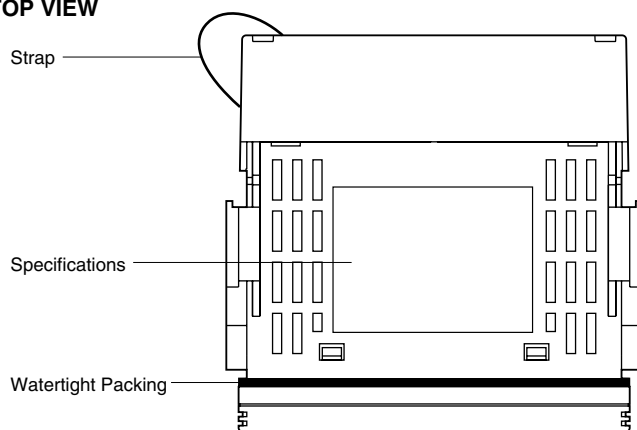

### FRONT VIEW

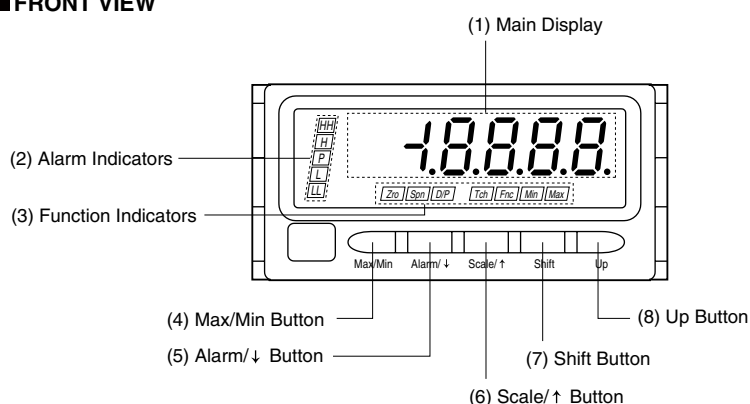

### SIDE VIEW

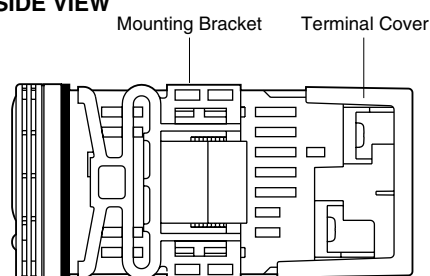

### COMPONENT IDENTIFICATION

No.	COMPONENT	FUNCTION
(1)	Main display	Indicates present values, setting values and status of the unit.
(2)	Alarm indicators *1	Indicate alarm status of the input signal. LL turns on when the LL alarm is tripped. L turns on when the L alarm is tripped. H turns on when the H alarm is tripped. HH turns on when the HH alarm is tripped. P turns on when none of the other alarms is tripped.
(3)	Function indicators	Indicate the status in each setting mode.
(4)	Max/Min button	Used to switch the main display to show the present values, maximum values or minimum values etc.
(5)	Alarm/↓ button	Used to confirm alarm setting value and to move on to the alarm and other setting modes; or to shift through setting items in each setting mode.
(6)	Scale/↑ button	Used to move on to the scaling and other setting modes; or to shift through setting items in each setting mode.
(7)	Shift button	Used to move on to the setting standby status of each setting mode and shift through display digits in each setting item.
(8)	Up button	Used to change setting values, to execute/cancel Forced Zero or to select setting values.

\*1. Only the 'P' indicator turns on with no-alarm-output type. 'LL' or 'HH' does not turn on with dual-alarm-output type.  
All setpoints can be independently set either for Hi or Lo alarm trip.

## INSTALLATION

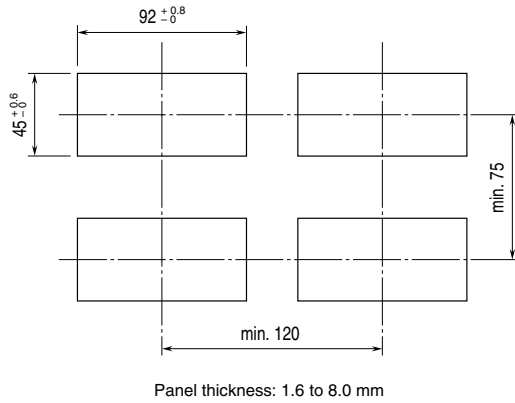

### ■ HOW TO MOUNT THE UNIT ON A PANEL

The watertight packing must be in place to hold the meter. Do not remove it.

- 1) Insert the unit into the panel cutout.
- 2) Push the mounting brackets into the grooves on both sides of the rear module, until they hit the panel's rear side.

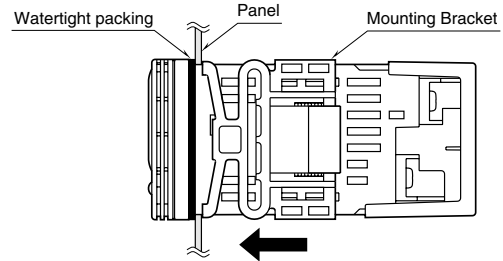

## TERMINAL CONNECTIONS

Connect the unit as in the diagram in the following page or refer to the connection diagram on the terminal cover.

### ■ EXTERNAL DIMENSIONS unit: mm (inch)

#### ■ TOP VIEW

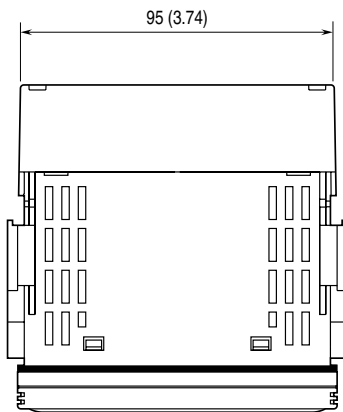

#### ■ FRONT VIEW

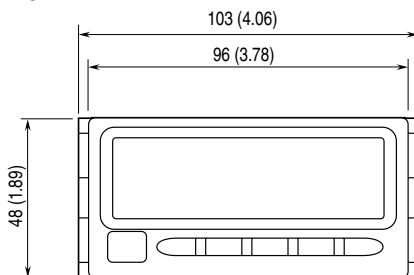

#### ■ SIDE VIEW

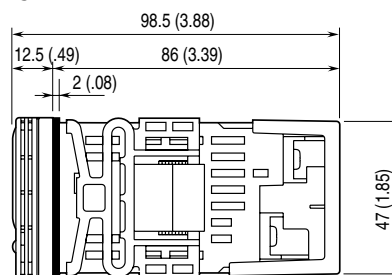

#### ■ REAR VIEW

##### • No Alarm Output

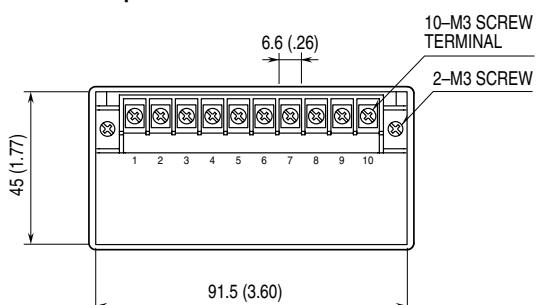

##### • Alarm Output

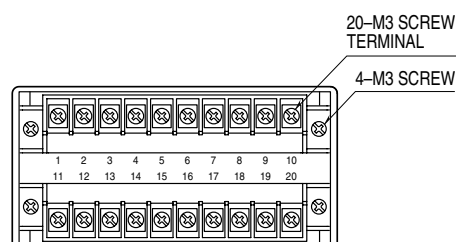

■ CONNECTION DIAGRAM

■ ALARM OUTPUT CODE 0: No alarm output

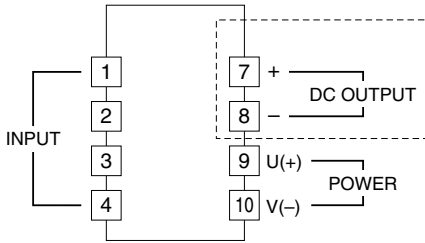

• Input code: 1, 2

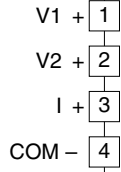

• Input code: 3

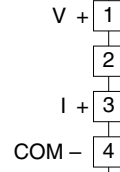

• Input code: 4

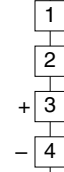

• Input code: 5, 6

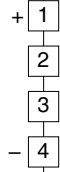

■ ALARM OUTPUT CODE 1: N.O. contact, 4 points

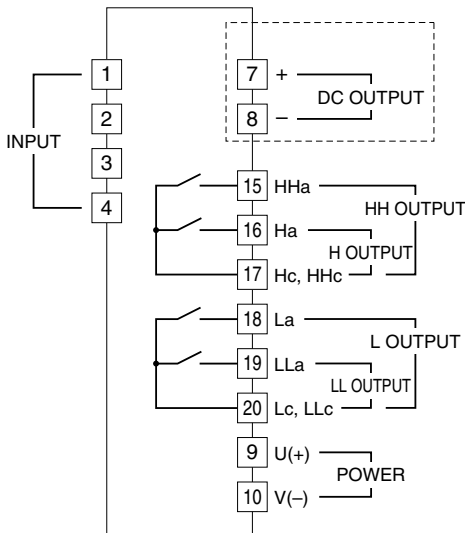

■ ALARM OUTPUT CODE 2: SPDT contact, 2 points

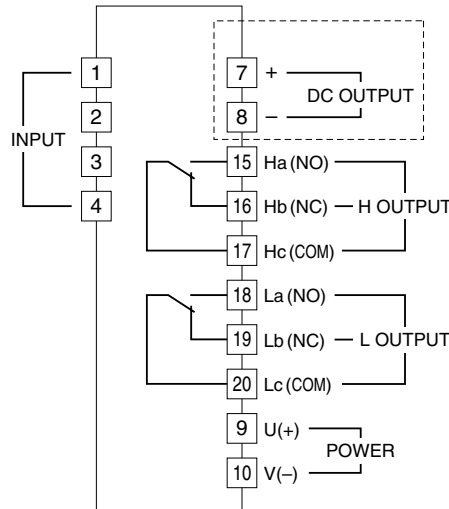

■ Relay Protection

• AC Powered

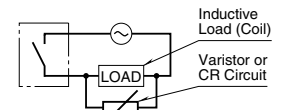

• DC Powered

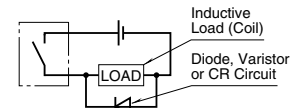

Note: The section enclosed by broken line is only with DC output option.

• Input Terminal Assignments

INPUT TYPE (indicator)	MEASURING RANGE	INPUT TERMINALS
V200 V10 V5 V1 A2-2 A1-1 V700	±200V ±10V ±5V ±1V ±2A ±1A ±700V	[1]-[4]
V01 V001	±100mV ±10mV	[2]-[4]

INPUT TYPE (indicator)	MEASURING RANGE	INPUT TERMINALS
V0-5 V1-5	0 - 5V 1 - 5V	[2]-[4]
A100 A1 A0-2 A4-2 A01	±100mA ±1mA 0 - 20mA 4 - 20mA ±100µA	[3]-[4]

■ TERMINAL BLOCK

• How to remove the terminal cover

Insert the minus tip of a screwdriver into each hole at the four corners of the cover and pull it to the direction as indicated below to separate the terminal cover.

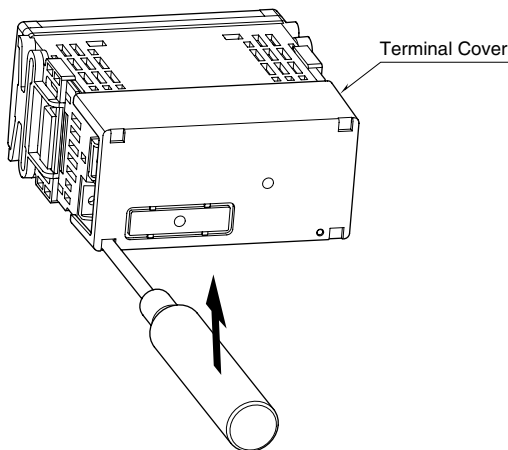

• How to remove the terminal block

The terminal block is separable in two pieces. Loosen two screws on both sides of the terminal block to separate. Be sure to turn off the power supply, input signal and power supply to the output relays before separating the terminal block.

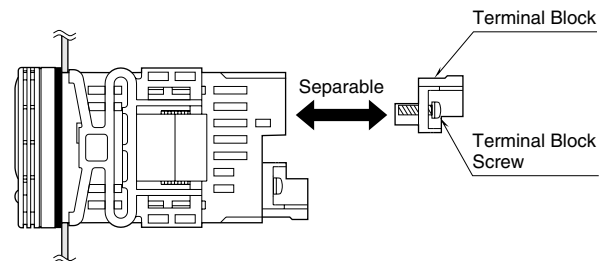

---

## WIRING INSTRUCTIONS

### ■ SCREW TERMINAL

Torque: 0.6 N·m

### ■ SOLDERLESS TERMINAL

Refer to the drawing below for recommended ring tongue terminal size. Spade tongue type is also applicable.

Applicable wire size: 0.25 to 1.65 mm<sup>2</sup> (AWG 22 to 16)

Recommended manufacturer: Japan Solderless Terminal MFG.Co.Ltd, Nichifu Co.,ltd

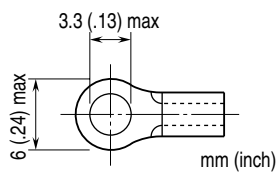

---

## LIGHTNING SURGE PROTECTION

We offer a series of lightning surge protectors for protection against induced lightning surges. Please contact us to choose appropriate models.