

BEFORE USE

Thank you for choosing M-System. Before use, please check contents of the package you received as outlined below.

If you have any problems or questions with the product, please contact M-System's Sales Office or representatives.

■ PACKAGE INCLUDES:

- Digital panel meter (1)
- Instruction manual..... (1)
- Engineering unit sticker label sheet (1)

■ MODEL NO.

Confirm Model No. marking on the product to be exactly what you ordered.

■ INSTRUCTION MANUAL

This manual describes necessary points of caution when you use this product, including installation, connection and basic maintenance procedures.

POINTS OF CAUTION**■ CONFORMITY WITH EC DIRECTIVES**

- This equipment is suitable for use in a Pollution Degree 2 environment and in Installation Category II, with the maximum operating voltage of 300V. Reinforced insulation is maintained between signal input, output and power input, basic insulation is between the input and DC output. Prior to installation, check that the insulation class of this unit satisfies the system requirements.
- Altitude up to 2000 meters
- The equipment must be installed such that appropriate clearance and creepage distances are maintained to conform to CE requirements. Failure to observe these requirements may invalidate the CE conformance.
- In order to enable the operator to turn off the power input immediately, install a switch or a circuit breaker according to the relevant requirements in IEC 60947-1 and IEC 60947-3 and properly indicate it.

■ POWER INPUT RATING & OPERATIONAL RANGE

Locate the power input rating marked on the product and confirm its operational range as indicated below:

- 100 – 240V AC rating: 85 – 264V, 50/60 Hz, approx. 6.5VA
- 24V DC rating: 24V ±10%, approx. 3W
- 110V DC rating: 85 – 150V, approx. 3W

■ GENERAL PRECAUTIONS

- Before you remove the unit or mount it, turn off the power supply and input signal for safety.
- Be sure to put the terminal cover on while the power is supplied.

■ ENVIRONMENT

- Indoor use
- When heavy dust or metal particles are present in the air, install the unit inside proper housing with sufficient ventilation.
- Do not install the unit where it is subjected to continuous vibration. Do not subject the unit to physical impact.
- Environmental temperature must be within -10 to +55°C (14 to 131°F) with relative humidity within 30 to 90% RH in order to ensure adequate life span and operation.
- Be sure that the ventilation slits are not covered with cables, etc.

■ REQUIREMENTS TO ENSURE IP66

- Observe the designated panel cutout size (W92 × H45 mm).
- The watertight packing included in the product package must be placed behind the front cover.
- Both mounting brackets must be fastened tightly until they hit the panel.
- Confirm visually that the packing is not contorted or excessively run off the edge after installation.

■ WIRING

- Make sure for safety that only qualified personnel perform the wiring.
- Do not install cables (power supply, input and output) close to noise sources (high frequency line, etc.).
- Do not bind these cables together with those in which noises are present. Do not install them in the same duct.

■ AND

The unit is designed to function as soon as power is supplied, however, a warm up for 10 minutes is required for satisfying complete performance described in the data sheet.

COMPONENT IDENTIFICATION

■ TOP VIEW

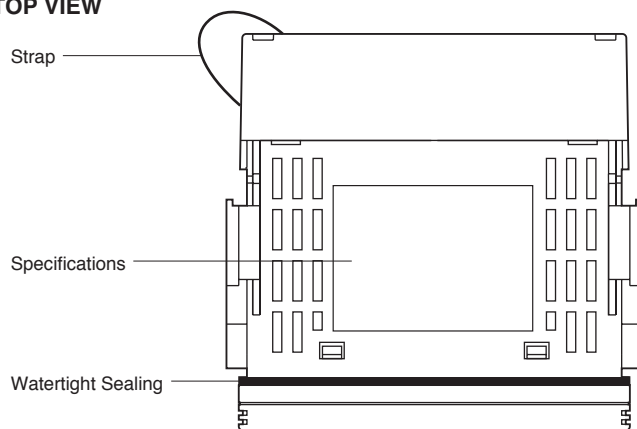

■ FRONT VIEW

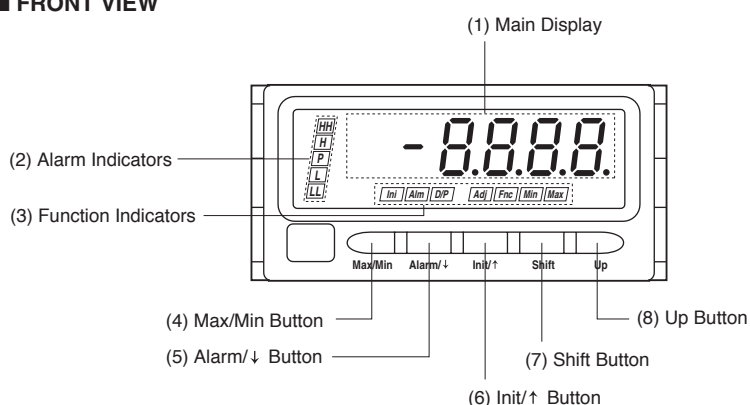

■ SIDE VIEW

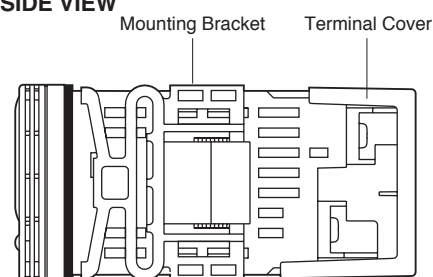

• COMPONENT IDENTIFICATION

No.	COMPONENT	FUNCTION
(1)	Main display	Indicates present values, setting values.
(2)	Alarm indicators *1	Indicate alarm status of the input signal. LL turns on when the LL alarm is tripped. L turns on when the L alarm is tripped. H turns on when the H alarm is tripped. HH turns on when the HH alarm is tripped. P turns on when none of the other alarms is tripped.
(3)	Function indicators	Indicate setting modes and status.
(4)	Max/Min button	Used to switch the main display to show present values, maximum values or minimum values.
(5)	Alarm/↓ button	Used to move on to the alarm setting mode; or to shift through setting items in each setting mode.
(6)	Init/↑ button	Used to move on to the initial setting mode; or to shift through setting items in each setting mode.
(7)	Shift button	Used to move on to the setting standby status and shift through display digits in each setting item.
(8)	Up button	Used to change setting values.

*1. Only the 'P' indicator turns on with no-alarm-output type. 'LL' or 'HH' does not turn on with dual-alarm-output type. All setpoints can be independently set either for Hi or Lo alarm trip.

INSTALLATION

■ PANEL CUTOUT unit: mm

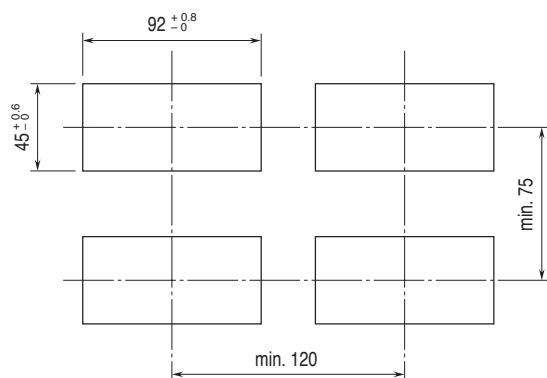

Panel thickness: 1.6 to 8.0 mm

■ HOW TO MOUNT THE UNIT ON A PANEL

The watertight packing must be in place to hold the meter. Do not remove it.

- 1) Insert the unit into the panel cutout.
- 2) Push the mounting brackets into the grooves on both sides of the rear module, until they hit the panel's rear side.

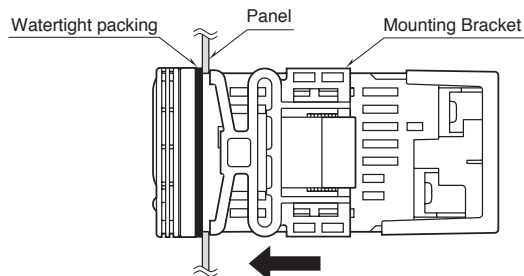

TERMINAL CONNECTIONS

Connect the unit as in the diagram in the following page or refer to the connection diagram on the terminal cover.

■ EXTERNAL DIMENSIONS unit: mm (inch)

■ TOP VIEW

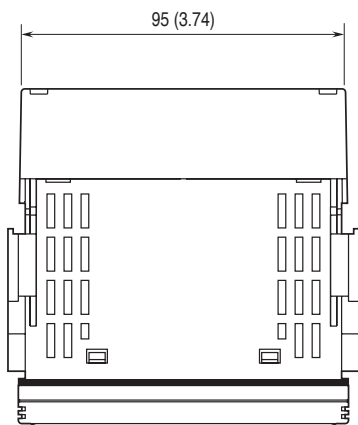

■ FRONT VIEW

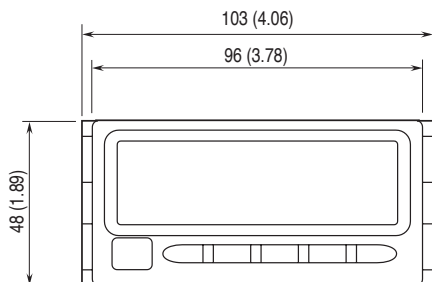

■ SIDE VIEW

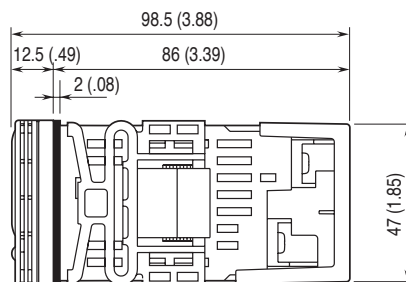

■ REAR VIEW

• No Alarm Output

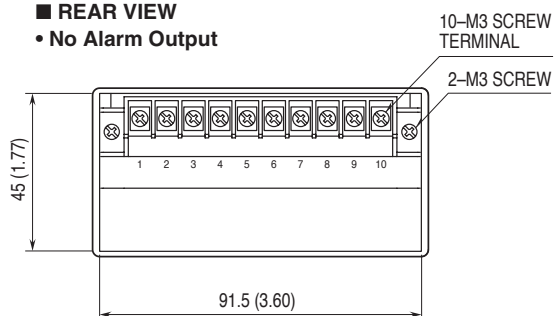

• Alarm Output

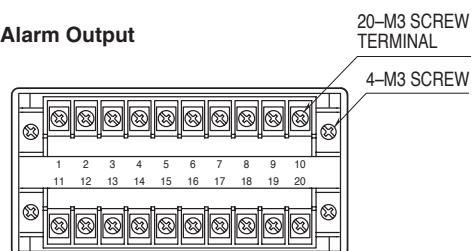

■ CONNECTION DIAGRAM

■ ALARM SUFFIX CODE 0: No alarm output

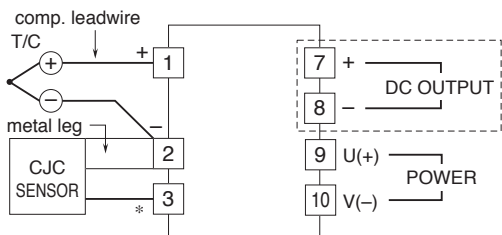

■ ALARM SUFFIX CODE 1: N.O. contact, 4 points

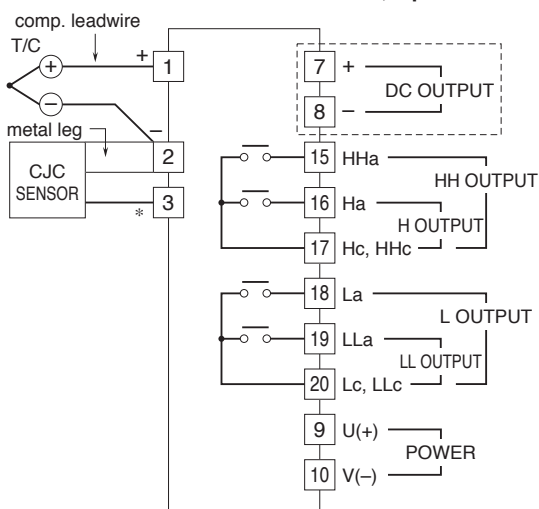

■ ALARM SUFFIX CODE 2: SPDT contact, 2 points

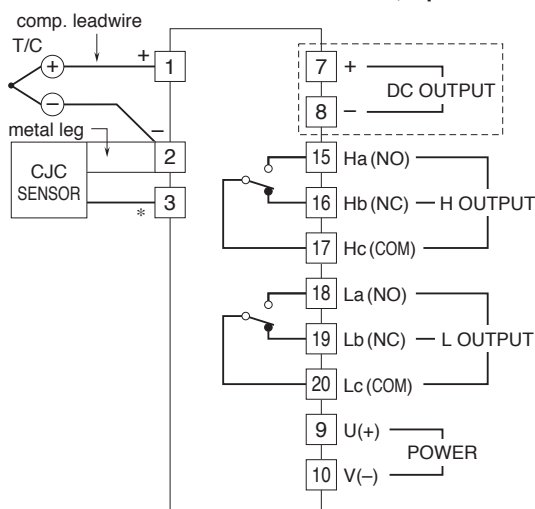

*DO NOT loosen the screw of the terminal 3. Loosen only the terminals 1 – 2 when connecting extension wires.
Note: The section enclosed by broken line is only with DC output option.

■ Relay Protection
• AC Powered

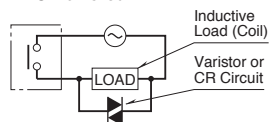

• DC Powered

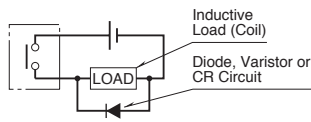

■ TERMINAL BLOCK

• How to remove the terminal block cover

Insert the minus tip of a screwdriver into each hole at the four corners of the cover and pull it to the direction as indicated below to separate the terminal block cover.

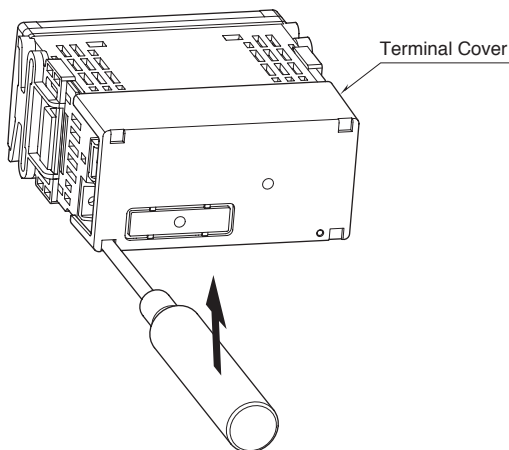

• How to remove the terminal block

The terminal block is separable in two pieces. Loosen two screws on both sides of the terminal block to separate. Be sure to turn off the power supply, input signal and power supply to the output relays before separating the terminal block.

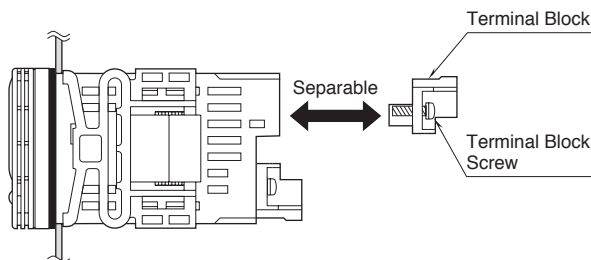

SETTING PROCEDURE

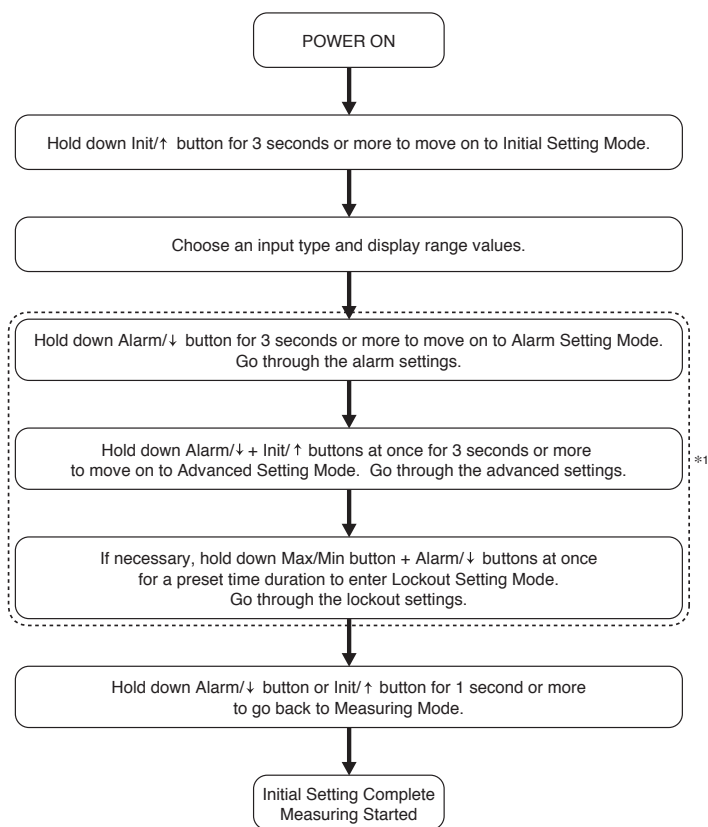

■ INITIAL SETTING FLOWCHART

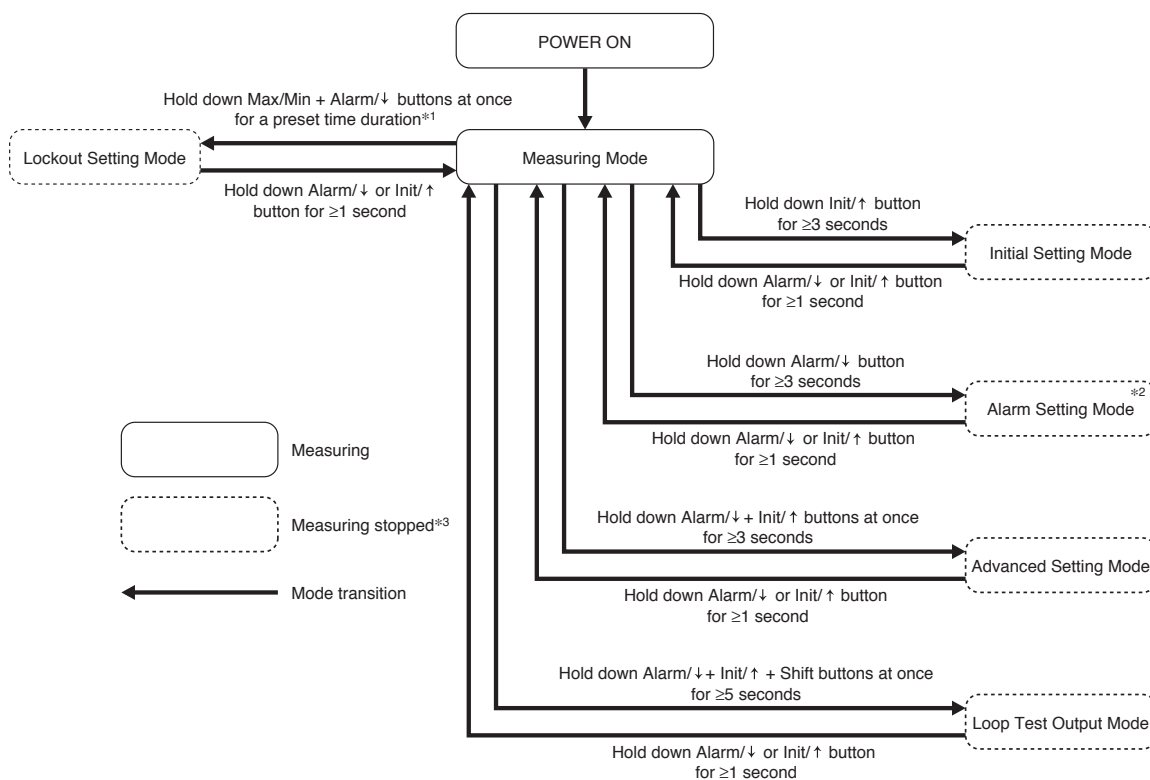

*1. Optional settings for parameters in a broken-line section.
Alarm Setting Mode is locked with no-alarm-output type.

■ GENERAL SETTING FLOWCHART



 Measuring
 Measuring stopped*3
 Mode transition

*1. Preset time can be specified with "Transition Time to Lockout Setting Mode" in Advanced Setting Mode.

*2. Alarm Setting Mode is locked with no-alarm-output type.

*3. The last measured values or status are held for DC and alarm outputs while the measuring is stopped. (Except the analog output adjustments during the loop test and the initial setting)

■ OPERATIONS IN MEASURING MODE

• Switching the main display to MAX or MIN values

Press Max/Min button to switch the main display to MAX or MIN values.

'Max' or 'Min' indicator turns on during the MAX/MIN display mode.

Press Max/Min button again for 1 second or more, or turn the power supply off and on to cancel the MAX/MIN display mode.

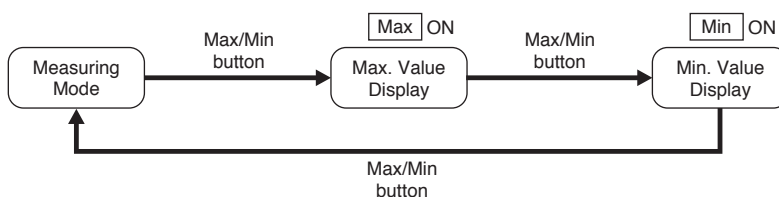

• Confirming alarm setpoints

Press Alarm/↓ button to confirm alarm setpoints.

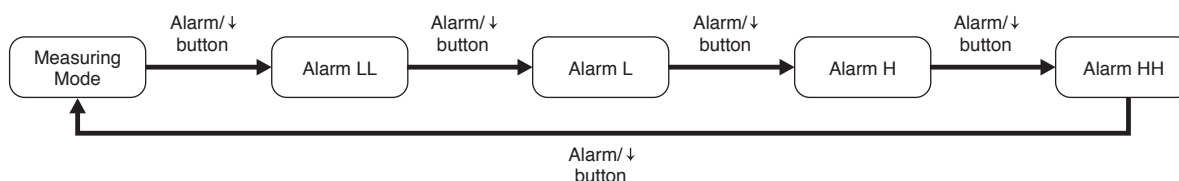

■ OPERATIONS IN SETTING MODES

• Main display

The main display shows the current settings while the panel meter is in the setting mode.

• Shifting through setting parameters

In any setting mode, pressing Alarm/↓ button shifts one parameter to the next. Pressing Init/↑ button shifts one to the previous.

• Changing parameters

Pressing Shift button while one of the parameter settings is indicated on the display shifts the panel meter into the setting standby mode. The digit to which you can apply changes starts blinking.

Press Up button to change the blinking value.

Press Shift button to go to the next digit.

Press Alarm/↓ or Init/↑ button to apply the new value and go to the next or previous parameter setting.

• If you get lost...

Hold down Max/Min button for 1 second or more to return to the measuring mode without applying the last changes. (Those which have been already applied by pressing Alarm/↓ or Init/↑ button are not cancelled.)

■ INITIAL SETTING MODE

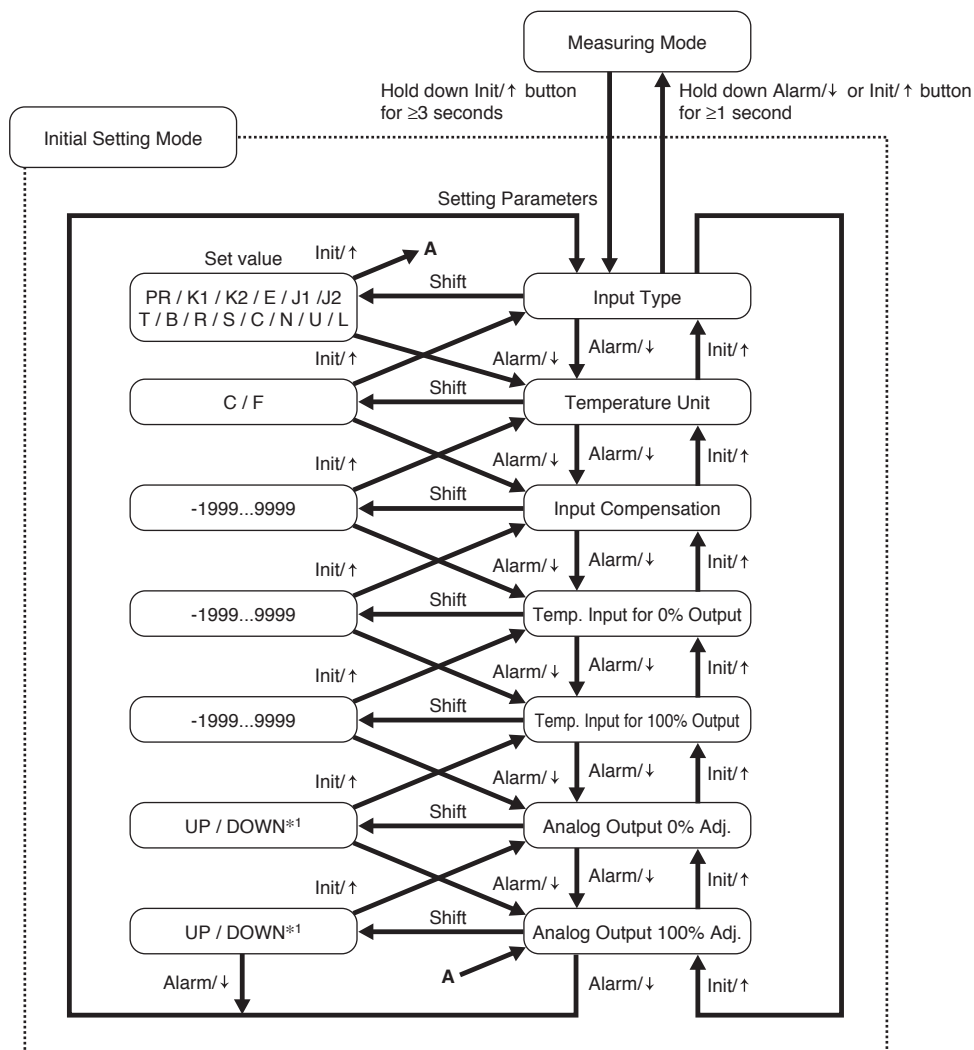

*1. Refer to the initial setting parameter list for detailed procedures.

PARAMETER	INDICATORS	DISPLAY	FUNCTION	DEFAULT VALUE
Input type	[Ini]	P_r	(PR)	P_1
		P_1	K (CA)	
		P_2	K (CA), narrow span	
		E	E (CRC)	
		J_1	J (IC)	
		J_2	J (IC), narrow span	
		t	T (CC)	
		b	B (RH)	
		r	R	
		S	S	
Temperature unit *1	[Ini]	C	°C	C
		F	°F	
Input compensation	[Ini] [Adj]	- 1999 ... 9999 *2	Temperature input offset setting	0000
Analog output 0%	[Ini] [Adj] [Min]	- 1999 ... 9999 *2	Temperature input for 0% output	0000
Analog output 100%	[Ini] [Adj] [Max]	- 1999 ... 9999 *2	Temperature input for 100% output	0 100
Analog output 0% adjustment	[Ini] [Adj]	UP (increasing)	Analog output 0% adjustment: adjustable range -5 to 105%	Adj
	[Fnc] [Min]	$down$ (decreasing)		
Analog output 100% adjustment	[Ini] [Adj]	UP (increasing)	Analog output 100% adjustment: adjustable range -5 to 105%	Adj
	[Fnc] [Max]	$down$ (decreasing)		

Input compensation: Offset temperature value is added at all measuring points. No gain setting.

Analog output 0% / 100%: 0% value < 100% value

Analog output 0% / 100% adjustment: Pressing [Shift] button switches the signal to increase or decrease, and then pressing [Up] button controls it toward the desired output value. 0% value < 100% value

*1. °F indication is not available for K2 and J2 input type.

*2. -199.9 to 999.9 for K2 and J2 input type. Temperature values must be re-set if the decimal point position is shifted due to an input type change from K2/J2 to other types, or to K2/J2 from others.

■ ALARM SETTING MODE

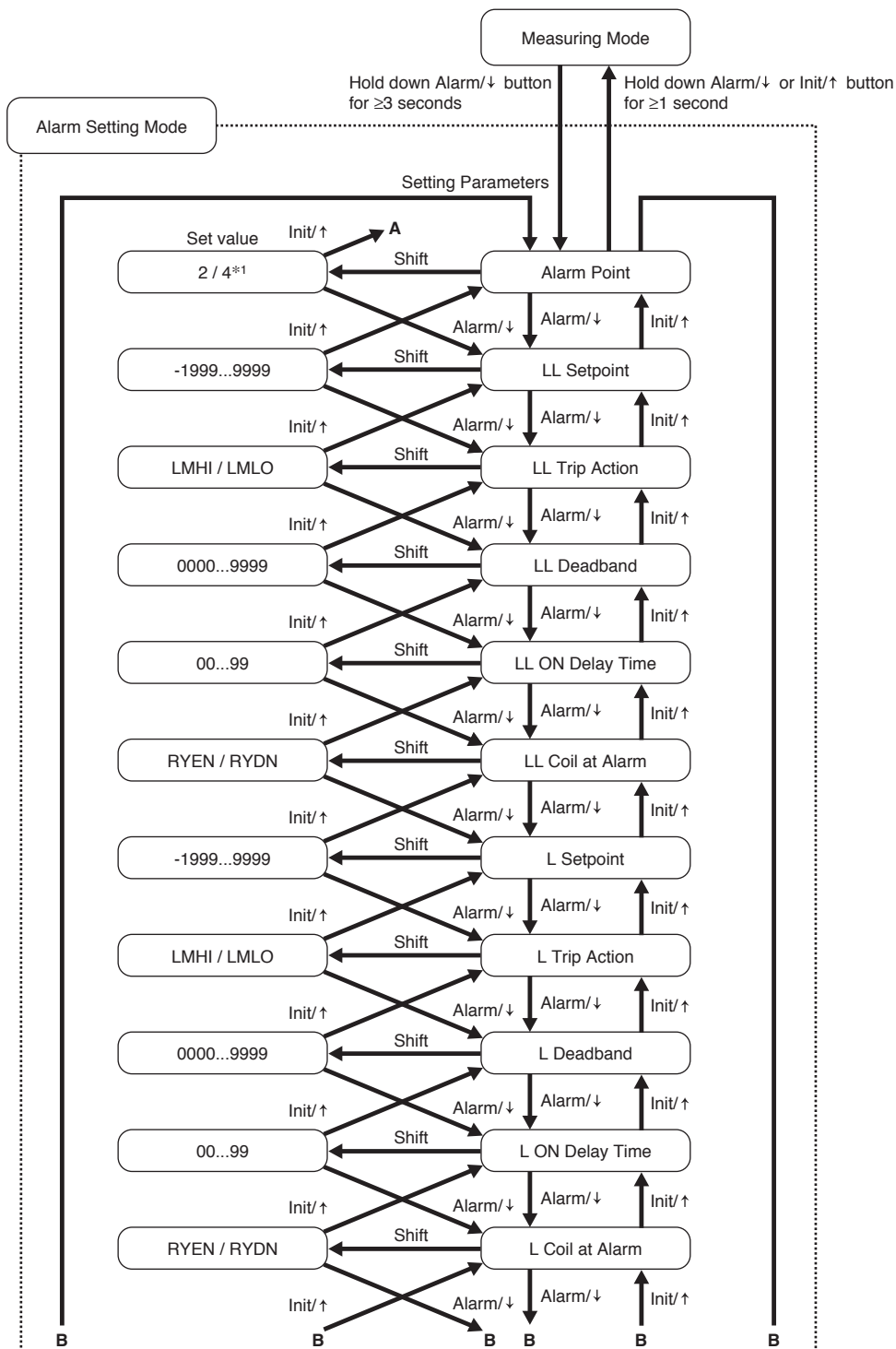

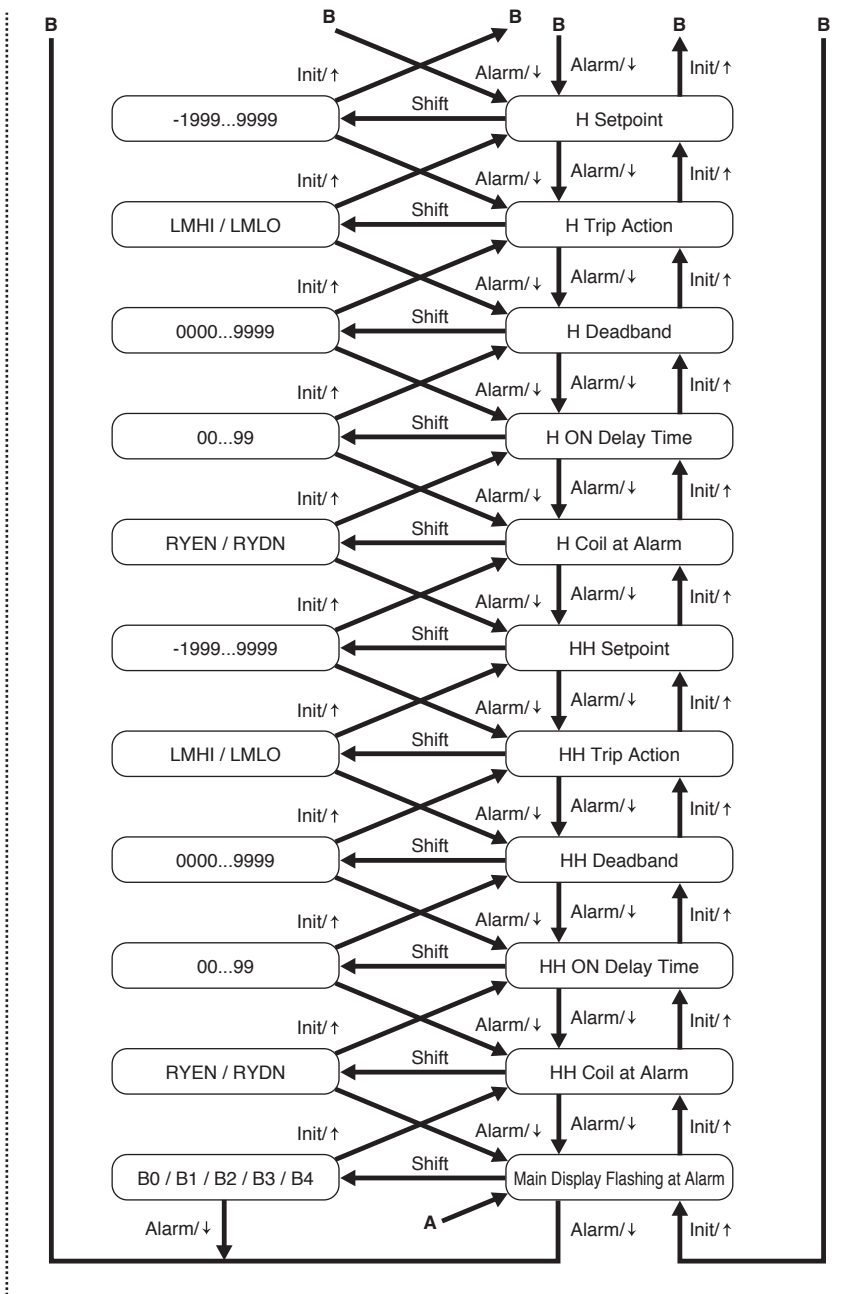

*1. Alarm point is fixed at "2" when the alarm model suffix code 2 is specified.

PARAMETER	INDICATORS	DISPLAY	FUNCTION	DEFAULT VALUE
Alarm points	<input type="checkbox"/> H <input type="checkbox"/> L <input type="checkbox"/> Fnc	<i>RLn2</i>	Dual alarm: L, H	<i>RLn2</i>
	<input type="checkbox"/> HH <input type="checkbox"/> H <input type="checkbox"/> L <input type="checkbox"/> LL <input type="checkbox"/> Fnc	<i>RLn4</i>	Quad alarm: LL, L, H, HH	<i>RLn4</i>
LL setpoint	<input type="checkbox"/> LL <input type="checkbox"/> Fnc	- 1999 ... 9999*1	LL: Setpoint value	0020
LL trip action	<input type="checkbox"/> LL <input type="checkbox"/> Fnc	<i>LnHi</i>	LL: Hi trip	<i>LnLo</i>
		<i>LnLo</i>	LL: Lo trip	
LL deadband (hysteresis)	<input type="checkbox"/> P <input type="checkbox"/> LL <input type="checkbox"/> Fnc	0000 ... 9999	LL: Deadband (hysteresis) value	0001
LL ON delay time	<input type="checkbox"/> LL <input type="checkbox"/> D/P <input type="checkbox"/> Fnc	00 ... 99	LL: ON delay time (seconds)	00
LL coil at alarm	<input type="checkbox"/> LL <input type="checkbox"/> Fnc	<i>rYEn</i>	LL: Coil energized at alarm	<i>rYEn</i>
		<i>rYdn</i>	LL: Coil de-energized at alarm	
L setpoint	<input type="checkbox"/> L <input type="checkbox"/> Fnc	- 1999 ... 9999*1	L: Setpoint value	0030
L trip action	<input type="checkbox"/> L <input type="checkbox"/> Fnc	<i>LnHi</i>	L: Hi trip	<i>LnLo</i>
		<i>LnLo</i>	L: Lo trip	
L deadband (hysteresis)	<input type="checkbox"/> P <input type="checkbox"/> L <input type="checkbox"/> Fnc	0000 ... 9999	L: Deadband (hysteresis) value	0001
L ON delay time	<input type="checkbox"/> L <input type="checkbox"/> D/P <input type="checkbox"/> Fnc	00 ... 99	L: ON delay time (seconds)	00
L coil at alarm	<input type="checkbox"/> L <input type="checkbox"/> Fnc	<i>rYEn</i>	L: Coil energized at alarm	<i>rYEn</i>
		<i>rYdn</i>	L: Coil de-energized at alarm	
H setpoint	<input type="checkbox"/> H <input type="checkbox"/> Fnc	- 1999 ... 9999*1	H: Setpoint value	0070
H trip action	<input type="checkbox"/> H <input type="checkbox"/> Fnc	<i>HnHi</i>	H: Hi trip	<i>HnHi</i>
		<i>HnLo</i>	H: Lo trip	
H deadband (hysteresis)	<input type="checkbox"/> P <input type="checkbox"/> H <input type="checkbox"/> Fnc	0000 ... 9999	H: Deadband (hysteresis) value	0001
H ON delay time	<input type="checkbox"/> H <input type="checkbox"/> D/P <input type="checkbox"/> Fnc	00 ... 99	H: ON delay time (seconds)	00
H coil at alarm	<input type="checkbox"/> H <input type="checkbox"/> Fnc	<i>rYEn</i>	H: Coil energized at alarm	<i>rYEn</i>
		<i>rYdn</i>	H: Coil de-energized at alarm	
HH setpoint	<input type="checkbox"/> HH <input type="checkbox"/> Fnc	- 1999 ... 9999*1	HH: Setpoint value	0080
HH trip action	<input type="checkbox"/> HH <input type="checkbox"/> Fnc	<i>HnHi</i>	HH: Hi trip	<i>HnHi</i>
		<i>HnLo</i>	HH: Lo trip	
HH deadband (hysteresis)	<input type="checkbox"/> P <input type="checkbox"/> HH <input type="checkbox"/> Fnc	0000 ... 9999	HH: Deadband (hysteresis) value	0001
HH ON delay time	<input type="checkbox"/> HH <input type="checkbox"/> D/P <input type="checkbox"/> Fnc	00 ... 99	HH: ON delay time (seconds)	00
HH coil at alarm	<input type="checkbox"/> HH <input type="checkbox"/> Fnc	<i>rYEn</i>	HH: Coil energized at alarm	<i>rYEn</i>
		<i>rYdn</i>	HH: Coil de-energized at alarm	
Main display flashing at alarm	<input type="checkbox"/> Fnc	<i>b 0</i>	No flashing	<i>b 0</i>
		<i>b 1</i>	Flashing in 1.0 sec. intervals	
		<i>b 2</i>	Flashing in 0.5 sec. intervals	
		<i>b 3</i>	Flashing in 0.2 sec. intervals	
		<i>b 4</i>	Flashing in 0.1 sec. intervals	

Note 1: Alarm Setting Mode is locked with no-alarm-output type.

Alarm points depend upon the model suffix code. LL and HH setpoints are usable only for quad alarm type.

Note 2: LED status: = ON, = Blinking

Note 3: Alarm is disabled when '----' is specified for the setpoint.

Note 4: All alarm setpoints are disabled (reset to '----' status) when the input type has been changed. Re-setting is required.

*1. -199.9 to 999.9 for K2 and J2 input type.

■ ADVANCED SETTING MODE

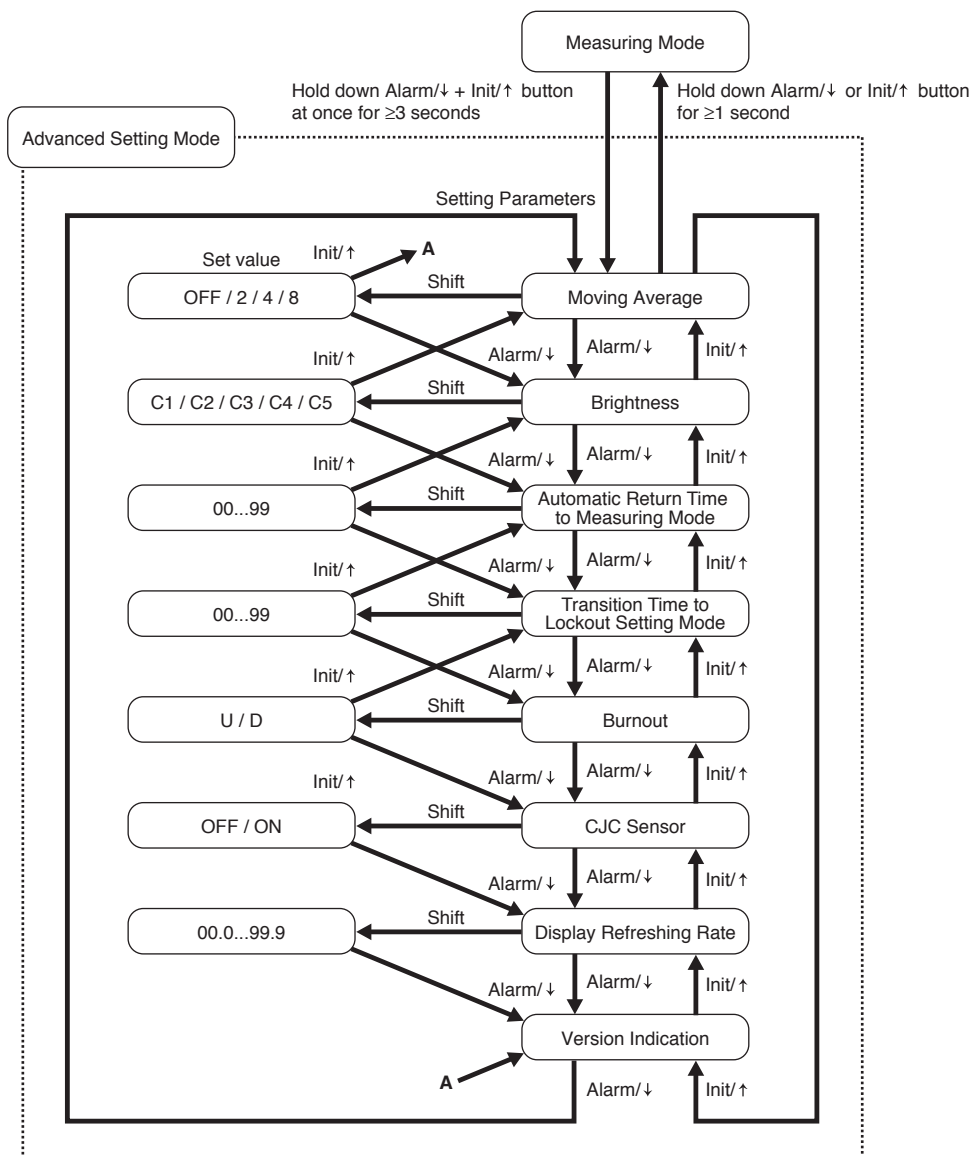

PARAMETER	INDICATORS	DISPLAY	FUNCTION	DEFAULT VALUE
Moving average	[Fnc]	<i>R</i> <i>o</i> <i>F</i> <i>F</i>	No moving averaging	<i>R</i> <i>o</i> <i>F</i> <i>F</i>
		<i>R</i> <i>2</i>	Moving average with 2 samples	
		<i>R</i> <i>4</i>	Moving average with 4 samples	
		<i>R</i> <i>8</i>	Moving average with 8 samples	
Brightness	[D/P] [Fnc]	[<i>l</i>] <i>1</i>	Brightness level 1 (dark)	[<i>l</i>] <i>3</i>
		[<i>l</i>] <i>2</i>	Brightness level 2	
		[<i>l</i>] <i>3</i>	Brightness level 3	
		[<i>l</i>] <i>4</i>	Brightness level 4	
		[<i>l</i>] <i>5</i>	Brightness level 5 (bright)	
Automatic return time to Measuring Mode	[D/P] [Fnc]	<i>r</i> <i>00</i> ... <i>r</i> <i>99</i>	Specify in seconds	<i>r</i> <i>15</i>
Transition time to Lockout Setting Mode	[D/P] [Fnc]	<i>P</i> <i>00</i> ... <i>P</i> <i>99</i>	Specify in seconds	<i>P</i> <i>05</i>
Burnout *1	[Fnc]	<i>b</i> <i>n</i> <i>U</i>	Upscale burnout	<i>b</i> <i>n</i> <i>U</i>
		<i>b</i> <i>n</i> <i>d</i>	Downscale burnout	
CJC sensor	[Fnc]	[<i>o</i>] <i>F</i> <i>F</i>	CJC sensor Disabled	[<i>o</i>] <i>n</i>
		[<i>o</i>] <i>n</i>	CJC sensor Enabled	
Display refreshing rate *2	[Fnc]	<i>F</i> <i>000</i> ... <i>F</i> <i>999</i>	Specify in seconds	<i>F</i> <i>000</i>
Version indication	[Fnc]	N/A	Version number, indication only	N/A

Automatic return time to Measuring Mode: The display goes back automatically to Measuring Mode if the front buttons are left untouched for the specified time period while it is in one of the setting modes (except the loop test output mode).

With this value set to 0, the display must always be exited manually from the setting mode.

Transition time to Lockout Setting Mode: The display goes to Lockout Setting Mode only when the designated buttons are pressed for the specified time duration.

CJC sensor: Specify either the cold junction compensation is enabled or not.

*1. Do not change the setting while in the burnout condition.

*2. F00.0 = 100 msec. refreshing rate

LOCKOUT SETTING MODE

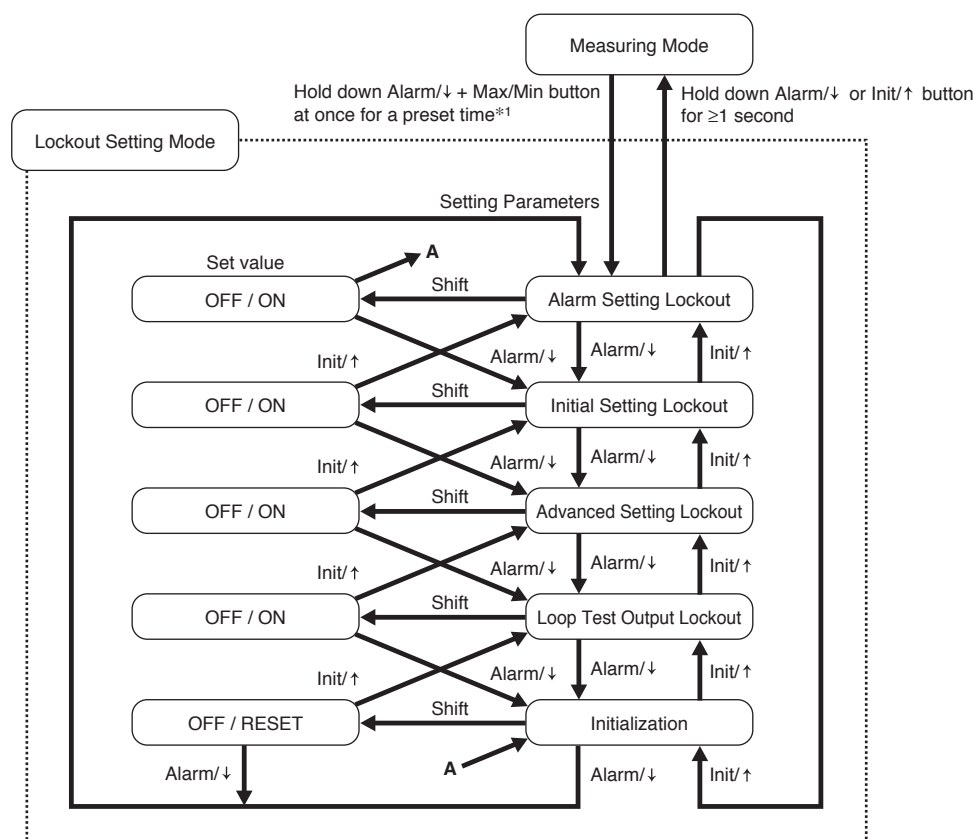

*1. Preset time can be specified with "Transition Time to Lockout Setting Mode" in Advanced Setting Mode.

PARAMETER	INDICATORS	DISPLAY	FUNCTION	DEFAULT VALUE
Alarm setting lockout	D/P Fnc	RoFF	Unlock Alarm Setting Mode	RoFF
		R on	Lock Alarm Setting Mode	
Initial setting lockout	D/P Fnc	oFF	Unlock Initial Setting Mode	oFF
		o n	Lock Initial Setting Mode	
Advanced setting lockout	D/P Fnc	doFF	Unlock Advanced Setting Mode	doFF
		d on	Lock Advanced Setting Mode	
Loop test output lockout	D/P Fnc	toFF	Unlock Loop Test Output Mode	toFF
		t on	Lock Loop Test Output Mode	
Initialization	D/P Fnc	roFF	No initialization	roFF
		rESt	Execute Initialization	

■ LOOP TEST OUTPUT MODE

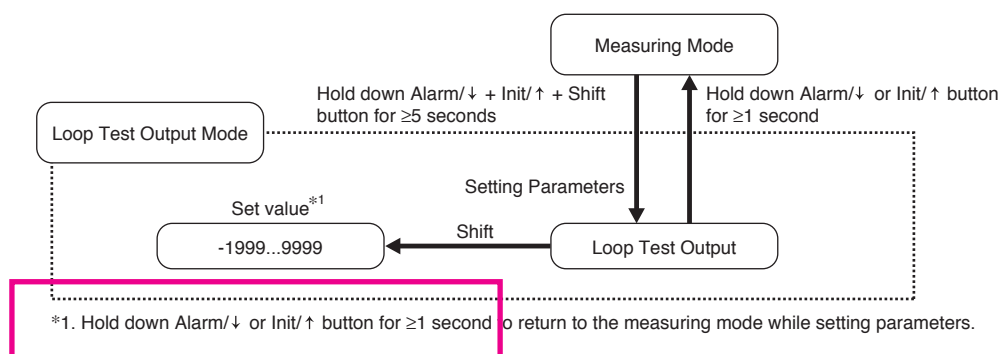

PARAMETER	INDICATORS	DISPLAY	FUNCTION	DEFAULT VALUE
Loop test output	<div style="display: flex; flex-wrap: wrap; gap: 5px;"> Ini Alm D/P </div> <div style="display: flex; flex-wrap: wrap; gap: 5px; margin-top: 5px;"> Adj Fnc </div> <div style="display: flex; flex-wrap: wrap; gap: 5px; margin-top: 5px;"> Min / Max </div>	- 1999 ... 9999* ¹ (display blinking)	Temperature value for the loop test output	N/A

Loop test output: Pressing [Shift] button switches the signal to increase ([Max] ON) or decrease ([Min] ON), and then pressing [Up] button controls it toward the desired output value.

*1. Temperature value can be specified within the usable range for the respective sensor types.
Decimal point position for K2 and J2 input type: -199.9 to 999.9

ERROR MESSAGES

MAIN DISPLAY	ERROR MESSAGE	WHAT TO DO
5Err	Input error, Out of the measuring range	Increase/decrease the input signal until it is back within the measuring range.
bErr	Input wire breakdown (burnout)* ¹	Check the input wires.
iErr	Non-volatile memory error (reading)	While the error message is on the display, press Up button for 3 seconds or more to initialize the unit to its factory default status.* ²
uErr	Non-volatile memory error (writing)	
rErr	Internal data error	Repair is needed if the display does not recover after the power is reset.

*1. CJC sensor's wire breakdown is not detectable.

*2. All parameter settings are reset to the factory default values. If the unit does not recover its function after the initialization, repairing in the factory may be required.

CHARACTER SET

0	1	2	3	4	5	6	7	8	9	-	A	B	C	D	E	F	G	H	I	J	K	L	M	N	O	P	Q	R	S	T	U	V	W	X	Y	Z
0	1	2	3	4	5	6	7	8	9	-	A	b	c	d	E	F	G	H	,	U	P	L	ñ	o	P	q	r	S	t	U	u	y	ü	ý	z	

LIGHTNING SURGE PROTECTION

M-System offers a series of lightning surge protectors for protection against induced lightning surges. Please contact M-System to choose appropriate models.

M-SYSTEM WARRANTY

M-System warrants such new M-System product which it manufactures to be free from defects in materials and workmanship during the 36-month period following the date that such product was originally purchased if such product has been used under normal operating conditions and properly maintained, M-System's sole liability, and purchaser's exclusive remedies, under this warranty are, at M-System's option, the repair, replacement or refund of the purchase price of any M-System product which is defective under the terms of this warranty. To submit a claim under this warranty, the purchaser must return, at its expense, the defective M-System product to the below address together with a copy of its original sales invoice.

THIS IS THE ONLY WARRANTY APPLICABLE TO M-SYSTEM PRODUCT AND IS IN LIEU OF ALL OTHER WARRANTIES, EXPRESS OR IMPLIED, INCLUDING ANY IMPLIED WARRANTIES OF MERCHANTABILITY OR FITNESS FOR A PARTICULAR PURPOSE. M-SYSTEM SHALL HAVE NO LIABILITY FOR CONSEQUENTIAL, INCIDENTAL OR SPECIAL DAMAGES OF ANY KIND WHATSOEVER.

M-System Co., Ltd., 5-2-55, Minamitsumori, Nishinari-ku, Osaka 557-0063 JAPAN, Phone: (06) 6659-8201, Fax: (06) 6659-8510, E-mail: info@m-system.co.jp