

POTENTIOMETER INPUT DIGITAL PANEL METER
(5 1/2 digit, LCD display type)

MODEL **47DM**

BEFORE USE

Thank you for choosing us. Before use, please check contents of the package you received as outlined below. If you have any problems or questions with the product, please contact our sales office or representatives.

■ PACKAGE INCLUDES:

Digital panel meter
(body + mounting bracket × 2 + watertight packing).....(1)
Engineering unit sticker label sheet.....(1)

■ MODEL NO.

Confirm Model No. marking on the product to be exactly what you ordered.

■ INSTRUCTION MANUAL

This manual describes necessary points of caution when you use this product, including installation, connection and basic maintenance procedures.

For detailed explanations to operate and program the module, please refer to Model 47DM Operating Manual (EM-9510-B).

The 47D Series is programmable either by using the front control buttons or the PC Configurator Software. For detailed information on the PC configuration, refer to the 47DCFG users manual.

Software and manuals are downloadable at our web site.

POINTS OF CAUTION

■ POWER INPUT RATING & OPERATIONAL RANGE

- Locate the power input rating marked on the product and confirm its operational range as indicated below:
100 – 240V AC rating: 85 – 264V, 50/60 Hz, ≤ 12VA
24V DC rating: 24V ±10%, ≤ 3.5W
110V DC rating: 85 – 150V, ≤ 3.5W

■ GENERAL PRECAUTIONS

- Before you remove the unit or mount it, turn off the power supply and input signal for safety.
- Be sure to put the terminal cover on while the power is supplied.

■ ENVIRONMENT

- Indoor use.
- When heavy dust or metal particles are present in the air, install the unit inside proper housing with sufficient ventilation.
- Do not install the unit where it is subjected to continuous vibration. Do not subject the unit to physical impact.
- Environmental temperature must be within -10 to +55°C (14 to 131°F) with relative humidity within 30 to 90% RH in order to ensure adequate life span and operation.
- Be sure that the ventilation slits are not covered with cables, etc.

■ REQUIREMENTS TO ENSURE IP66

- Observe the designated panel cutout size (W92 × H45 mm).
- The watertight packing included in the product package must be placed behind the front cover.
- Both mounting brackets must be fastened tightly until they hit the panel.
- Confirm visually that the packing is not contorted or excessively run off the edge after installation.

■ WIRING

- Make sure for safety that only qualified personnel perform the wiring.
- Do not install cables close to noise sources (high frequency line, etc.).
- Do not bind these cables together with those in which noises are present. Do not install them in the same duct.

■ TERMINAL BLOCK

• How to remove the terminal cover

Insert the minus tip of a screwdriver into each hole at the four corners of the cover and pull it to the direction as indicated below to separate the terminal cover.

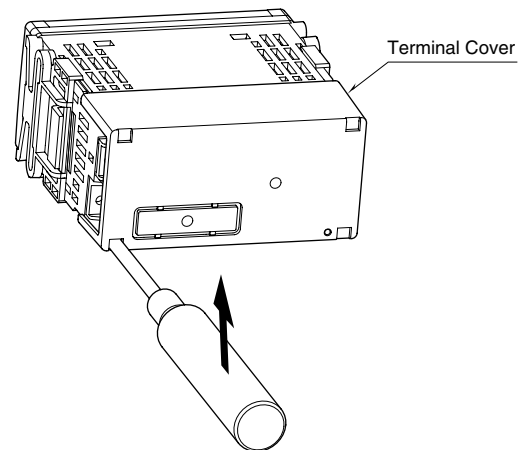

• How to remove the terminal block

The terminal block is separable in two pieces. Loosen two screws on both sides of the terminal block to separate. Be sure to turn off the power supply, input signal and power supply to the output relays before separating the terminal block.

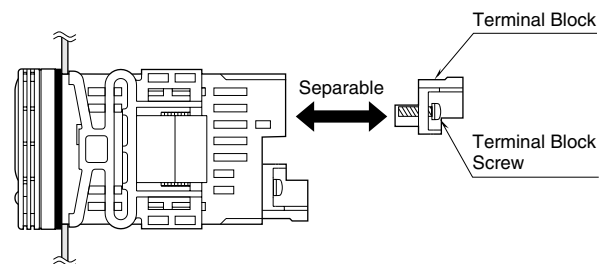

■ EX-FACTORY SETTING (/SET)

- Activating “initialization” of Lockout Setting Mode, Ex-factory settings or user’s specified parameters will be deleted and overwritten with the factory default values. Notice that after this, Ex-factory settings will be irrecoverable.

■ AND

- The unit is designed to function as soon as power is supplied, however, a warm up for 10 minutes is required for satisfying complete performance described in the data sheet.
- Delay power off for 10 seconds or more after changing of settings including the one set with Zero signal.

VIEWING ANGLE

The display is designed to provide the optimal legibility when viewed from the angles as shown below.

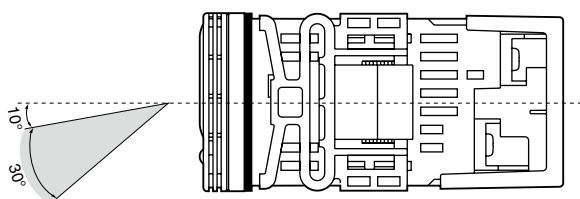

INSTALLATION

■ PANEL CUTOUT unit: mm

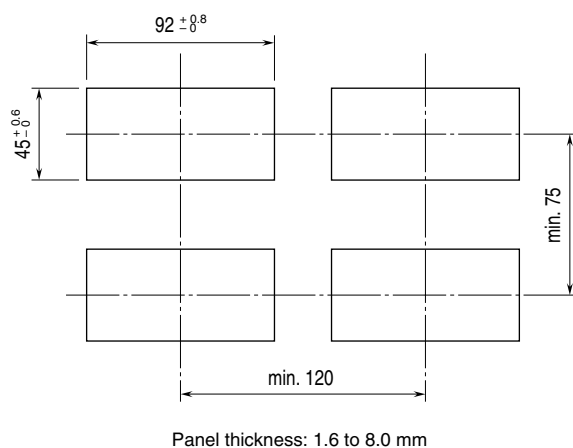

LIGHTNING SURGE PROTECTION

We offer a series of lightning surge protectors for protection against induced lightning surges. Please contact us to choose appropriate models.

■ HOW TO MOUNT THE UNIT ON A PANEL

The watertight packing must be in place to hold the meter. Do not remove it.

- 1) Insert the unit into the panel cutout.
- 2) Push the mounting brackets into the grooves on both sides of the rear module, until they hit the panel’s rear side.

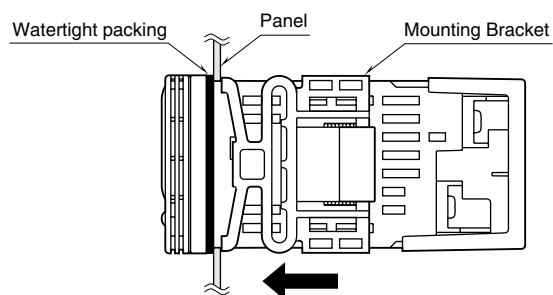

COMPONENT IDENTIFICATION

■ TOP VIEW

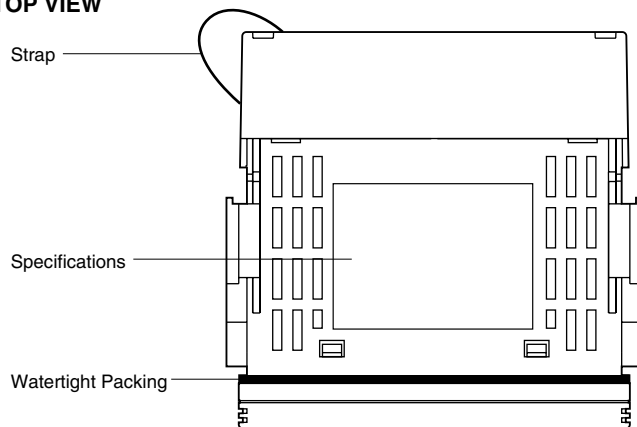

■ FRONT VIEW

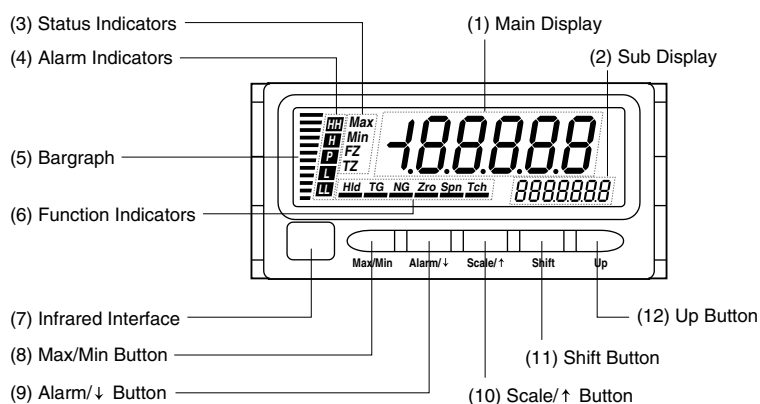

■ SIDE VIEW

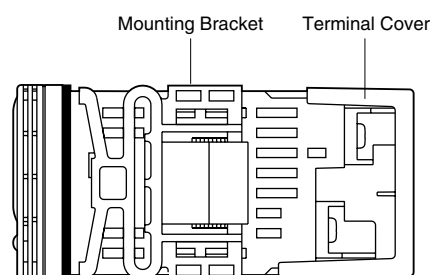

• COMPONENT IDENTIFICATION

No.	COMPONENT	FUNCTION
(1)	Main display	Indicates present values, setting values and status of the unit.
(2)	Sub display	Indicates the present setting mode.
(3)	Status indicators	Indicate Max/Min display mode, Forced zero mode and Tare adjustment mode.
(4)	Alarm indicators	Indicate alarm status of the input signal.
(5)	Bargraph	Indicates present signal level against the scaled range.
(6)	Function indicators	Indicate the device status.
(7)	Infrared interface	Used for the infrared communication.
(8)	Max/Min button	Used to switch the main display to show present values, maximum values or minimum values etc.
(9)	Alarm/↓ button	Used to confirm alarm setpoints and to move on to the alarm and other setting modes; or to shift through setting items in each setting mode.
(10)	Scale/↑ button	Used to move on to the scaling and other setting modes; or to shift through setting items in each setting mode.
(11)	Shift button	Used to move on to the setting standby status and shift through display digits in each setting item.
(12)	Up button	Used to change and apply setting values; or to execute/cancel Forced Zero and tare adjustment.

Note: Refer to the operating manual for details on each function.

TERMINAL CONNECTIONS

Connect the unit as in the diagram in the following page or refer to the connection diagram on the terminal cover.

EXTERNAL DIMENSIONS unit: mm (inch)

TOP VIEW

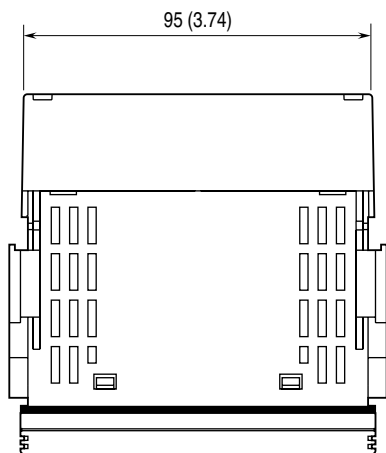

FRONT VIEW

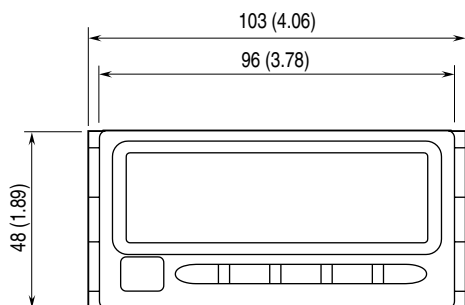

SIDE VIEW

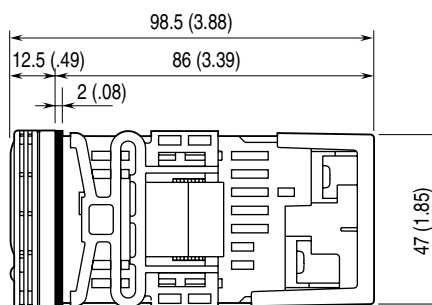

REAR VIEW

No Options

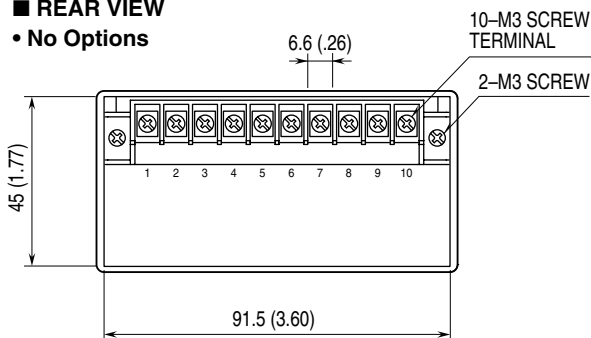

Alarm Output, RS-485/Modbus

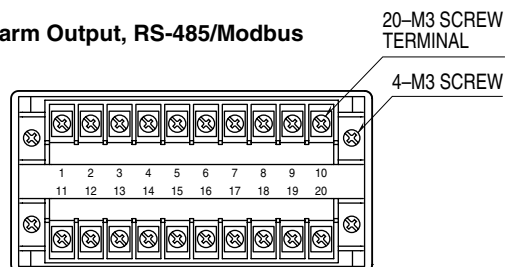

BCD Output, Event Trigger Input, Alarm Output (Photo MOSFET Relay)

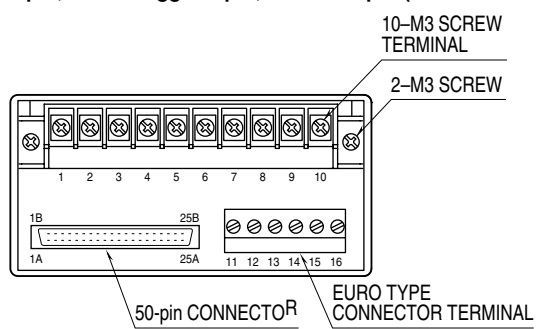

CONNECTION

Input, excitation supply, DC output, relay output, network interface, power: M3 separable screw terminal (nickel plated steel (standard) or stainless steel; torque 0.6 N·m)

Photo MOSFET relay, event trigger input: Euro type connector terminal (applicable wire size: max. 1.3 dia., 0.5 – 1.25 mm², stripped length 7 – 8 mm)

BCD output: 50-pin connector
(Honda Tsushin Kogyo HDR-E50LFDT1-SLE+)

■ CONNECTION DIAGRAM

■ REAR TERMINAL ASSIGNMENTS

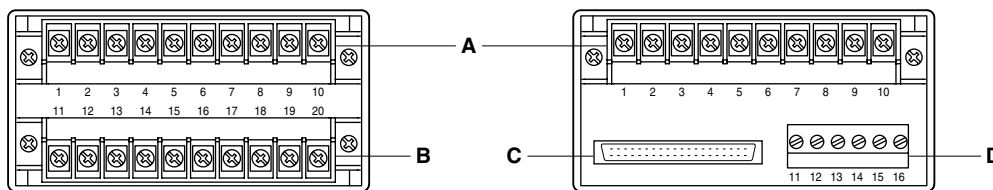

■ A : BASIC

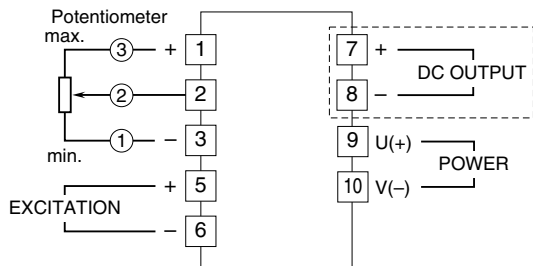

Note: The section enclosed by broken line is only with DC output option.

• Excitation Supply Connection Examples

+12V Sensor Excitation

Max. 80mA is allowed on the sensor excitation loop.
The excitation is Not isolated from the potentiometer input.
DO NOT SHORT across the terminals 1 / 2 / 3 and 5 / 6.

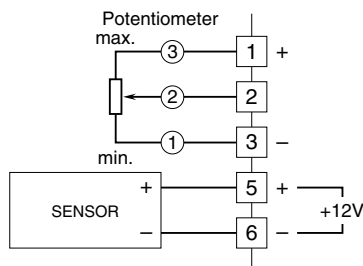

+24V Two-wire Transmitter Excitation

The excitation supply can be used to power a two-wire transmitter.
The excitation is Not isolated from the potentiometer input.
DO NOT SHORT across the terminals 1 / 2 / 3 and 5 / 6.

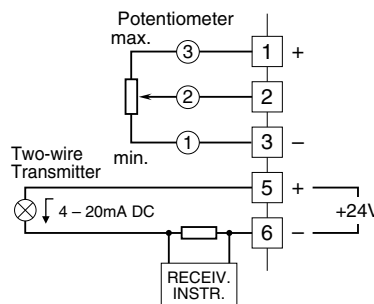

■ B

• Alarm Output : N.O. contact, 4 points

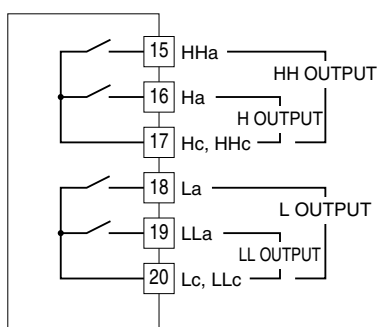

• Alarm Output : SPDT contact, 2 points

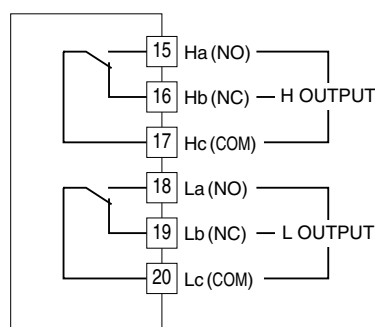

• RS-485 / Modbus RTU

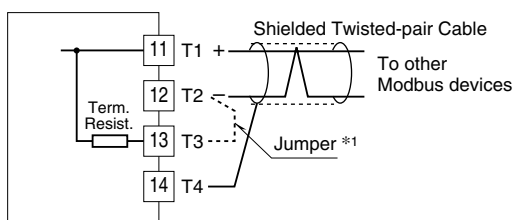

*1. When the device is located at the end of a transmission line via twisted-pair cable (when there is no cross-wiring), close across the terminal 12 – 13 with a leadwire. When the device is not at the end, no shortcircuit wire is required.

■ Relay Protection

• AC Powered

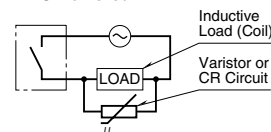

• DC Powered

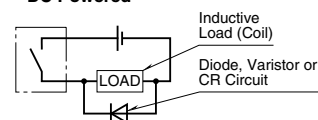

■ C : BCD OUTPUT

• Connector Pin Assignment



PIN NO.	ASSIGNMENT	PIN NO.	ASSIGNMENT
1A	COM	1B	Do 38
2A	COM	2B	COM
3A	LL	3B	Do 34
4A	L	4B	COM
5A	PASS	5B	Do 32
6A	H	6B	COM
7A	HH	7B	Do 31
8A	POL	8B	COM
9A	RESET	9B	Do 28
10A	HOLD	10B	COM
11A	MIN_REQ	11B	Do 24
12A	MAX_REQ	12B	COM
13A	REQ	13B	Do 22
14A	COM	14B	COM
15A	RUN	15B	Do 21
16A	DAV	16B	Do 68
17A	OVF	17B	Do 18
18A	Do 58	18B	Do 64
19A	Do 54	19B	Do 14
20A	Do 52	20B	Do 62
21A	Do 51	21B	Do 12
22A	Do 48	22B	Do 61
23A	Do 44	23B	Do 11
24A	Do 42	24B	COM
25A	Do 41	25B	COM

Open collector

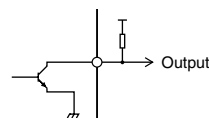

Output Logic

Voltage Level at ON	Output Logic
Hi	Positive
Lo	Negative

Connected to a digital display (example)

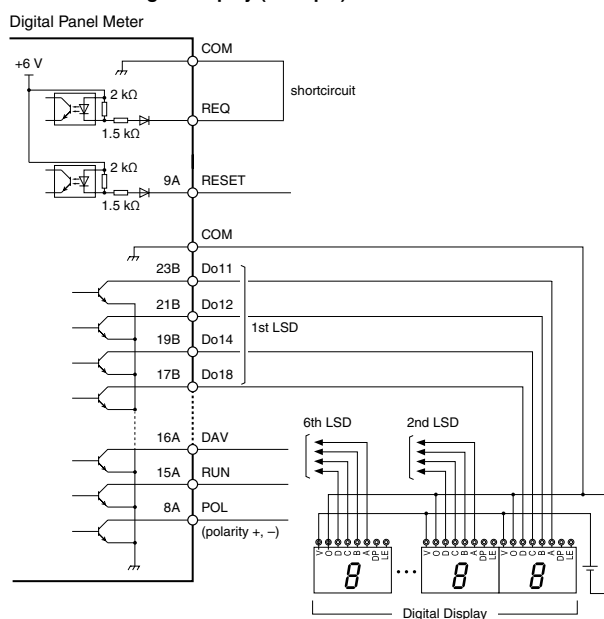

Use Special cable (model: HDR40) and Connector Terminal Block (model: CNT).
Refer to the cable's data sheet for pin assignments.

Connected to a PLC (example)

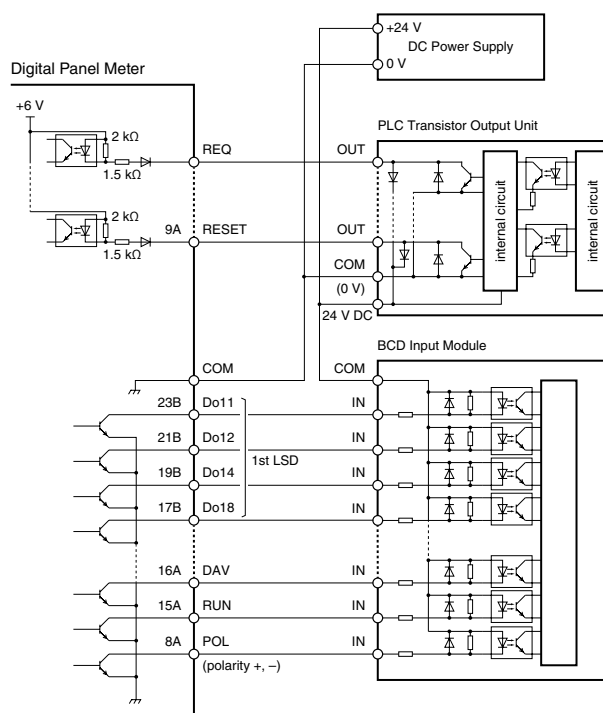

■ D

• Alarm Output : Photo MOSFET Relay N.O. contact, 4 points

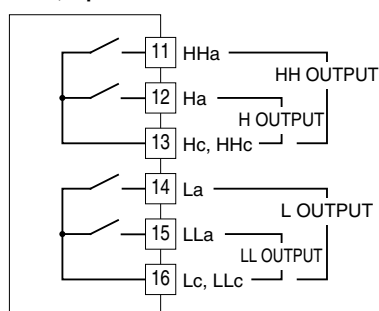

• Event Trigger Input

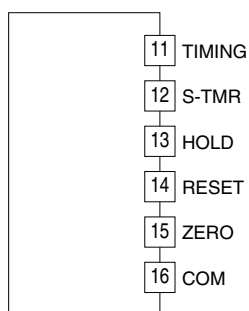

Connection Example

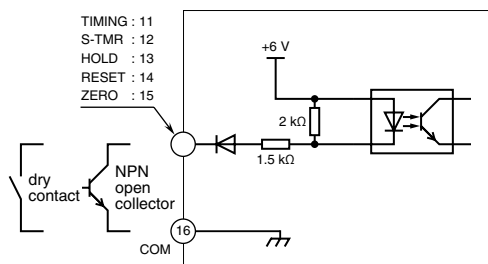

MODBUS WIRING CONNECTION

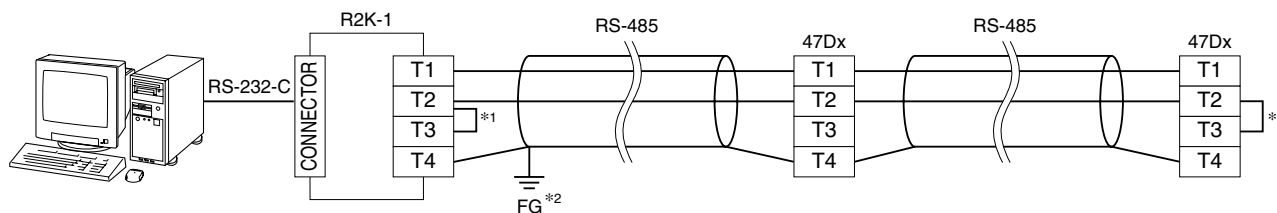

*1. Internal terminating resistor is used when the device is at the end of a transmission line.

*2. Install shield cables to all sections and ground them at single point.

PC CONFIGURATION VIA INFRARED COMMUNICATION

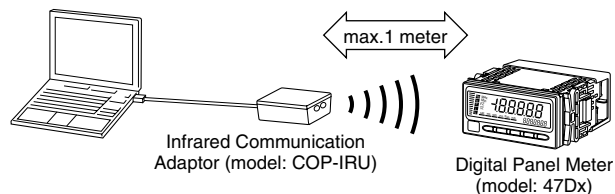

Note 1. Hold down Alarm/↓ + Up buttons at once for 3 seconds to move on to Infrared Communication mode (IRU indicated).
Hold down Alarm/↓ or Scale/↑ button for 1 second to cancel the mode.
Analog output and Modbus functions are stopped while in this mode.

Note 2. The COP-IRU can communicate with single panel meter only. DO NOT turn more than one panel meter on to the infrared communication mode.

SYSTEM CONFIGURATION EXAMPLES

■ RS-485 / RS-232-C

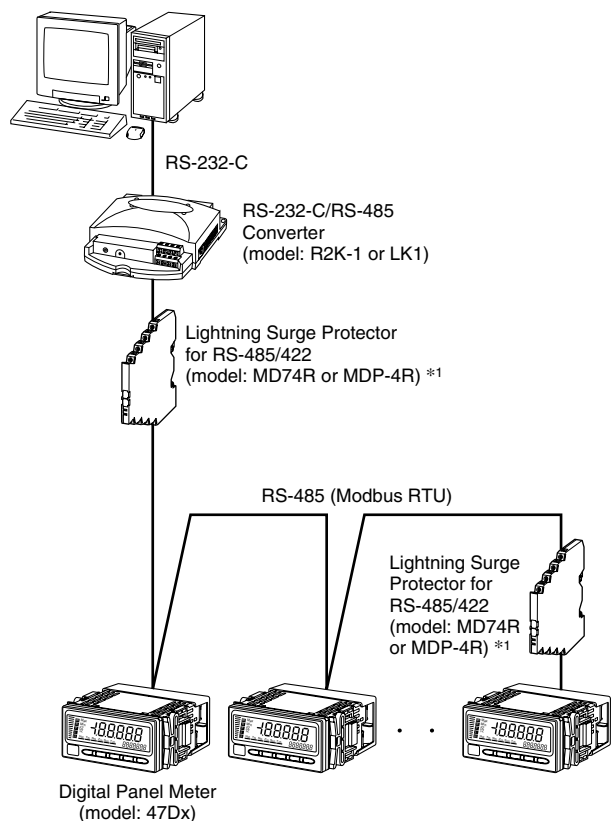

■ RS-485 / ETHERNET

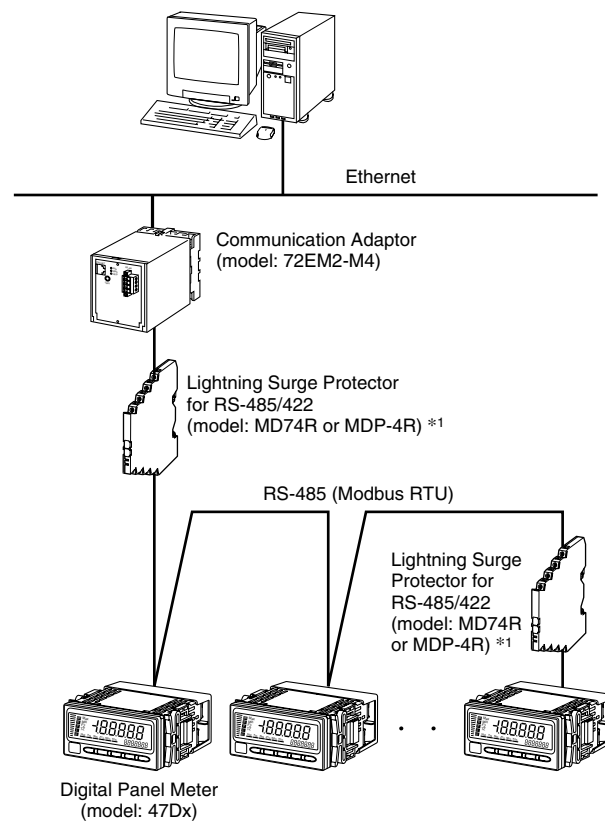

*1. Insert lightning surge protectors recommended in this example if necessary.