

## Digital Panel Meters 40 Series

### RTD INPUT DIGITAL PANEL METER

(4 digits, process meter)

#### Functions & Features

- 4 digit ( $\pm 9999$ ) panel meter
- HOLD functions
- High visible, 0.8" (20.3mm) high and bright LED

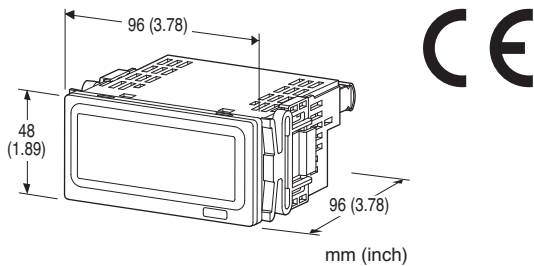

### MODEL: 40DR-R1-[1][2]

#### ORDERING INFORMATION

- Code number: 40DR-R1-[1][2]
- Specify a code from below for each of [1] and [2].  
(e.g. 40DR-R1-R/Q)
- Specify the specification for option code /Q  
(e.g. /C01/SET)

#### INPUT

**R1:** Pt 100 (JIS'97, IEC)

(Usable range -200 to +850°C, -328 to +1562°F)

Pt 100 (JIS'89)

(Usable range -200 to +650°C, -328 to +1202°F)

#### [1] POWER INPUT

##### AC Power

**K3:** 100 - 120V AC

(Operational voltage range 85 - 132 V, 47 - 66 Hz)

**L3:** 200 - 240V AC

(Operational voltage range 170 - 264 V, 47 - 66 Hz)

##### DC Power

**R:** 24 V DC

(Operational voltage range 24 V  $\pm 20$  %, ripple 10 %p-p max.)

#### [2] OPTIONS

**blank:** none

**/Q:** With options (specify the specification)

#### SPECIFICATIONS OF OPTION: Q (multiple selections)

##### COATING (For the detail, refer to M-System's web site.)

Moving parts and indicators are not coated.

**/C01:** Silicone coating

**/C02:** Polyurethane coating

**/C03:** Rubber coating

##### EX-FACTORY SETTING

**/SET:** Preset according to the Ordering Information Sheet  
(No. ESU-9533)

#### GENERAL SPECIFICATIONS

**Construction:** Panel flush mounting

**Connection:** M3 screw terminals (torque 0.6 N·m)

**Solderless terminal:** Refer to the drawing at the end of the section.

**Recommended manufacturer:** Japan Solderless Terminal MFG.Co.Ltd, Nichifu Co.,Ltd

**Applicable wire size:** 0.25 to 1.65 mm<sup>2</sup> (AWG 22 to 16)

**Screw terminal:** Nickel-plated steel

**Housing material:** Flame-resistant resin (gray)

**Isolation:** Input to power

**A/D conversion:**  $\Sigma - \Delta$

**Sampling rate:** 10 times/sec. (100 msec.)

**Averaging:** None or moving average

**Setting:** (Front button)

- Temperature unit
- Moving average
- Brightness
- Others

##### Recommended solderless terminal

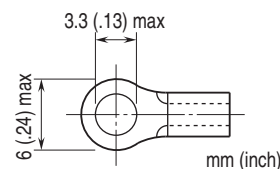

#### DISPLAY

**Display:** 4 digits of 20.3 mm (0.8 inch) height, 7-segment, red LED

**Display range:** -9999 to 9999

**Decimal point position:** 10<sup>-1</sup> or none

**Zero indication:** Higher-digit zeros are suppressed.

**Over-range indication:**

'S.ERR' blinks surpassing the permissible range.

'B.ERR' blinks at burnout.

**Engineering unit indication:** Sticker label attached

DC, AC, mV, V, kV,  $\mu$ A, mA, A, kA, mW, W,

kW, var, kvar, Mvar, VA, Hz,  $\Omega$ , k $\Omega$ , M $\Omega$ ,

cm, mm, m, m/sec, mm/min, cm/min, m/min,

m/h, m/s<sup>2</sup>, inch, l, l/s, l/min, l/h, m<sup>3</sup>, m<sup>3</sup>/sec,

m<sup>3</sup>/min, m<sup>3</sup>/h, Nm<sup>3</sup>/h, N·m, N/m<sup>2</sup>, g, kg, kg/h,

N, kN, Pa, kPa, MPa, t, t/h, °C, °F, %RH, J,  
kJ, MJ, rpm, sec, min, pH, %, ppm, etc.

## INPUT SPECIFICATIONS

### ■ RTD (3-wire)

**Maximum leadwire resistance:** 10 Ω per wire

**Sensing current:** Approx. 0.5 mA

**Usable range (conformance range):**

Pt100 (JIS'97, IEC) -200 to +850°C or -328 to +1562°F

Pt100 (JIS'89) -200 to +650°C or -328 to +1202°F

**Operational range:** -230 to +880°C or -382 to +1616°F

■ **Hold Input:** Dry contact input

**Detecting level:** ≤ 1.5 V

**Sensing:** Approx. 5 V DC, 1 mA

## INSTALLATION

**Power consumption**

•AC:

Approx. 1.3 VA for 100 - 120 V

Approx. 1.2 VA for 200 - 240 V

•DC: Approx. 0.5 W

**Operating temperature:** -10 to +55°C (14 to 131°F)

**Operating humidity:** 30 to 90 %RH (non-condensing)

**Mounting:** Panel flush mounting

**Weight:** 160 g (0.35 lb)

## PERFORMANCE

**Accuracy**

-200 - +200°C: ±0.2°C rdg ±1 digit

200 - 850°C: ±0.6°C rdg ±1 digit

-328 - +1562°F: ±1°F rdg ±1 digit

**Temp. coefficient:** ±0.1 °C/°C

**Line voltage effect:** ±1 digit over voltage range

**Insulation resistance:** ≥ 100 MΩ with 500 V DC

**Dielectric strength:** 1500 V AC @1 minute (input to power to ground)

## STANDARDS & APPROVALS

**EU conformity:**

EMC Directive

EMI EN 61000-6-4

EMS EN 61000-6-2

Low Voltage Directive

EN 61010-1

Installation Category II

Pollution Degree 2

Input to power: Reinforced insulation (300 V)

RoHS Directive

## DISPLAY HOLD COMMAND

Displayed value is held with an external HOLD command input. Connect the contacts across HOLD to COM.

(a) 5V-CMOS, TTL

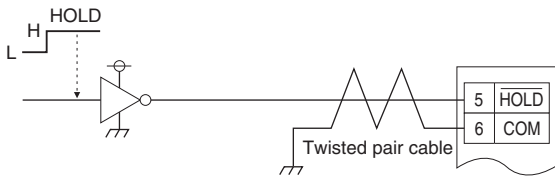

(c) Photo-Coupler

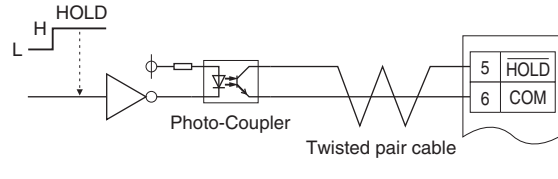

(b) Transistor

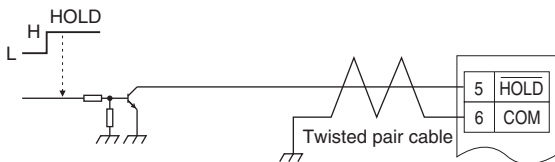

(d) Relay

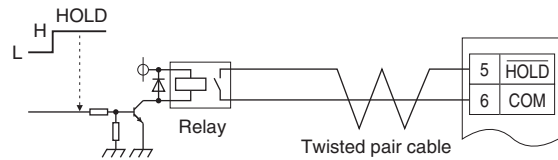

## EXTERNAL VIEW

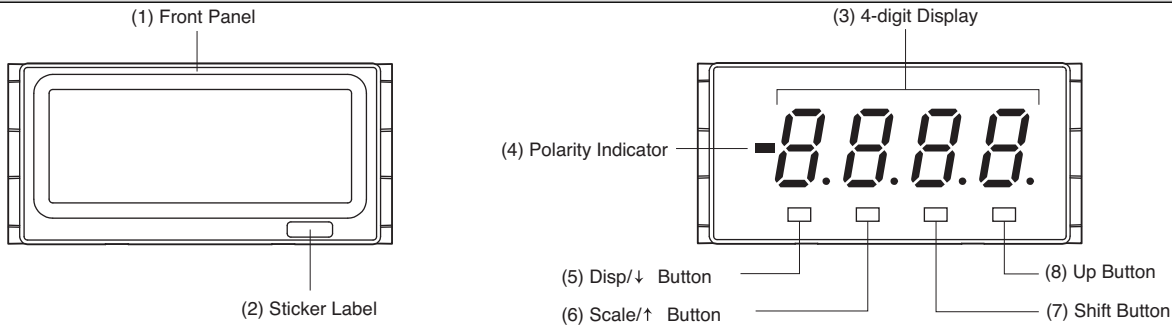

### COMPONENT IDENTIFICATION

No.	COMPONENT	FUNCTIONS
(1)	Front panel	Removed at conuguration.
(2)	Sticker label	Engineering unit label position
(3)	4-digit display	4-digit LED display. Range: 0 to 9999 (not including decimal point)
(4)	Polarity indicator	Turns on when negative value is displayed
(5)	Disp/↓ button	Used to move on to the display setting modes; or to shift through setting items in each setting mode.
(6)	Scale/↑ button	Used to move on to the zero & span adjustment modes; or to shift through setting items in each setting mode.
(7)	Shift button	Used to move on to the setting standby status and shift through display digits in each setting item.
(8)	Up button	Used to select setting value.

## PARAMETER LIST

### ■ ZERO & SPAN ADJUSTMENTS

PARAMETER	DISPLAY	FUNCTION	DEFAULT VALUE
Zero adjustment	- 9999 - 9999	Adjustment value for -200°C To distinguish from span adjustment, the first decimal point is blinking	-200.0
Span adjustment	- 9999 - 9999	Adjustment value for 850°C	850.0
Temperature unit	℃	Display in Celsius	℃
	℉	Display in Fahrenheit (Temperature range: -328 to +1562°F)*1	
Decimal Point Position	10 <sup>-1</sup> or none	Decimal point position for celsius	888.8

\*1. For Fahrenheit, the value is rounded to integer. Decimal point position setting is not available.

### ■ DISPLAY SETTING MODE

PARAMETER	DISPLAY	FUNCTION	DEFAULT VALUE
Moving Average	OFF	No moving averaging	A 4
	A 2	Moving average with 2 samples	
	A 4	Moving average with 4 samples	
	A 8	Moving average with 8 samples	
	A 16	Moving average with 16 samples	
Brightness	℃ 1	Brightness level 1 (dark)	℃ 5
	℃ 2	Brightness level 2	
	℃ 3	Brightness level 3	
	℃ 4	Brightness level 4	
	℃ 5	Brightness level 5 (bright)	
Initialization	OFF	Non-initialization	OFF
	RESET	Initialize settings (change to factory settings) *1	
Version Indication	-	Version number, indication only	-

\*1. While "RESET" is shown, pressing Disp/↓ button or Scale/↑ button initializes settings.

Activating "initialization", user's specified parameters will be deleted and overwritten with the factory default values. Notice that after this, Ex-factory settings will be irrecoverable.

**EXTERNAL DIMENSIONS & TERMINAL ASSIGNMENTS unit: mm (inch)**

■ TOP VIEW

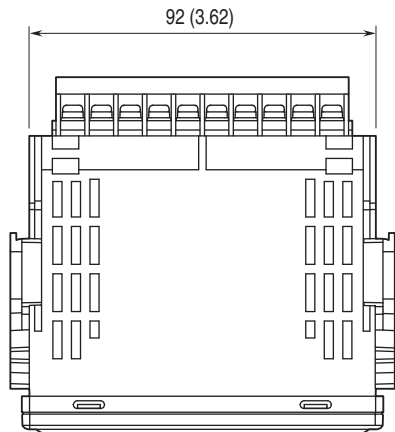

■ FRONT VIEW

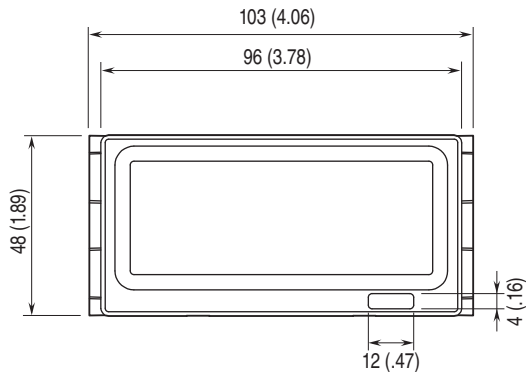

■ SIDE VIEW

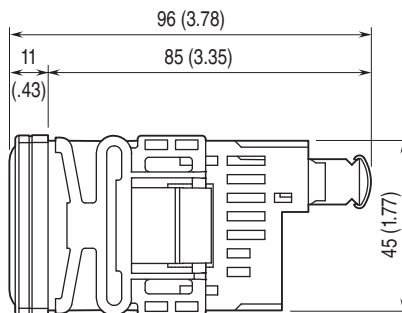

■ REAR VIEW

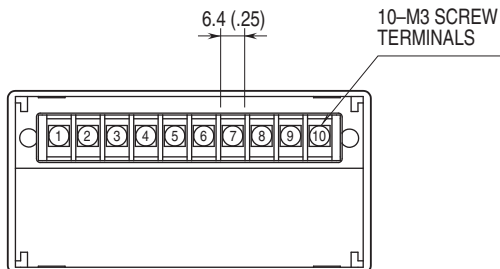

**MOUNTING REQUIREMENTS unit: mm**

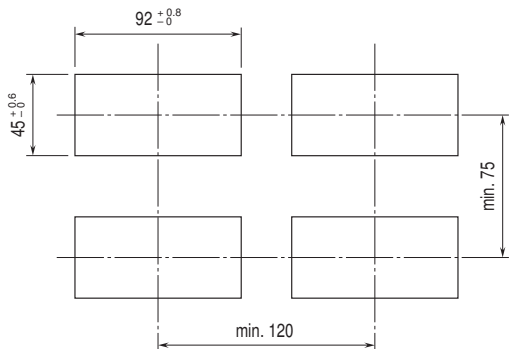

Panel thickness: 1.6 to 8.0 mm

**SCHEMATIC CIRCUITRY & CONNECTION DIAGRAM**

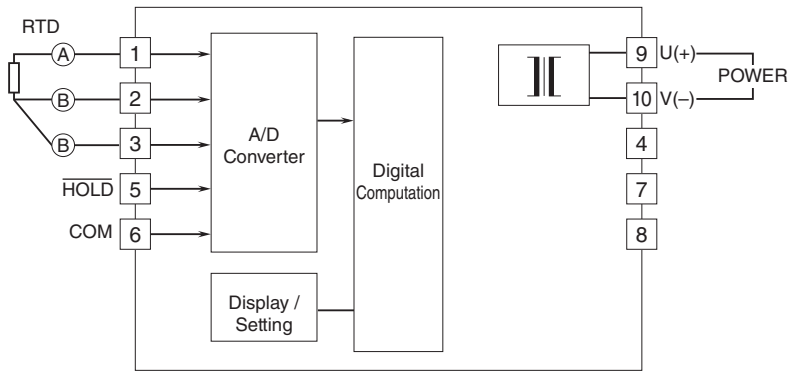

Specifications are subject to change without notice.