

<b>THERMOCOUPLE INPUT DIGITAL PANEL METER</b> (4 digits, process meter)	MODEL <b>40DT</b>
--	-------------------

**BEFORE USE ....**

Thank you for choosing us. Before use, please check contents of the package you received as outlined below. If you have any problems or questions with the product, please contact our sales office or representatives.

**■ PACKAGE INCLUDES:**

- Digital panel meter
- (body + CJC sensor + mounting bracket × 2) .....(1)
- Engineering unit sticker label sheet.....(1)

**■ MODEL NO.**

Confirm Model No. marking on the product to be exactly what you ordered.

**■ INSTRUCTION MANUAL**

This manual describes necessary points of caution when you use this product, including installation, connection and basic maintenance procedures. For detailed explanations to operate this product, please refer to Operating Manual (EM-9535-B), downloadable at our web site.

**POINTS OF CAUTION**

**■ CONFORMITY WITH EU DIRECTIVES**

- This equipment is suitable for Pollution Degree 2 and Installation Category II (transient voltage 2500V). Reinforced insulation (input to power: 300V) is maintained. Prior to installation, check that the insulation class of this unit satisfies the system requirements.
- Altitude up to 2000 meters.
- The equipment must be installed such that appropriate clearance and creepage distances are maintained to conform to CE requirements. Failure to observe these requirements may invalidate the CE conformance.
- The actual installation environments such as panel configurations, connected devices, connected wires, may affect the protection level of this unit when it is integrated in a panel system. The user may have to review the CE requirements in regard to the whole system and employ additional protective measures to ensure the CE conformity.
- In order to enable the operator to turn off the power input immediately, install a switch or a circuit breaker according to the relevant requirements in IEC 60947-2 and properly indicate it.

**■ POWER INPUT RATING & OPERATIONAL RANGE**

- Locate the power input rating marked on the product and confirm its operational range as indicated below:
  - 100 – 120V AC rating: 85 – 132V, 47 – 66 Hz, approx. 1.0VA
  - 200 – 240V AC rating: 170 – 264V, 47 – 66 Hz, approx. 1.0VA
  - 24V DC rating: 24V ±20%, approx. 0.3W

**■ GENERAL PRECAUTIONS**

- Before you remove the unit or mount it, turn off the power supply and input signal for safety.
- Be sure to put the terminal cover on while the power is supplied.

**■ ENVIRONMENT**

- Indoor use.
- When heavy dust or metal particles are present in the air, install the unit inside proper housing with sufficient ventilation.
- Do not install the unit where it is subjected to continuous vibration. Do not subject the unit to physical impact.
- Environmental temperature must be within -10 to +55°C (14 to 131°F) with relative humidity within 30 to 90% RH in order to ensure adequate life span and operation.
- Be sure that the ventilation slits are not covered with cables, etc.

**■ WIRING**

- Make sure for safety that only qualified personnel perform the wiring.
- Do not install cables close to noise sources (high frequency line, etc.).
- Do not bind these cables together with those in which noises are present. Do not install them in the same duct.

**■ EX-FACTORY SETTING (/SET)**

- Activating “initialization” of Display Setting Mode, Ex-factory settings or user’s specified parameters will be deleted and overwritten with the factory default values. Notice that after this, Ex-factory settings will be irrecoverable.

**■ AND ....**

- The unit is designed to function as soon as power is supplied, however, a warm up for 10 minutes is required for satisfying complete performance described in the data sheet.

## INSTALLATION

### ■ PANEL CUTOUT unit: mm

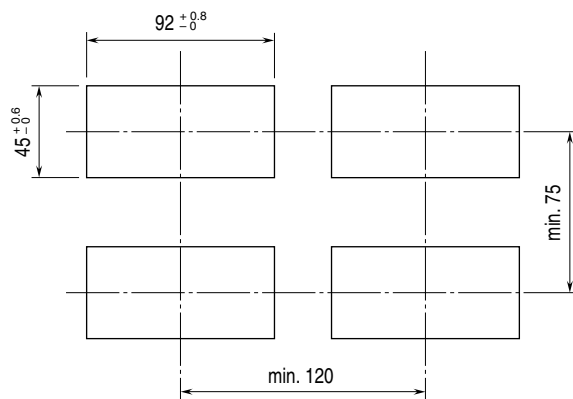

Panel thickness: 1.6 to 8.0 mm

### ■ HOW TO MOUNT THE UNIT ON A PANEL

- 1) Insert the unit into the panel cutout.
- 2) Push the mounting brackets into the grooves on both sides of the rear module, until they hit the panel's rear side.

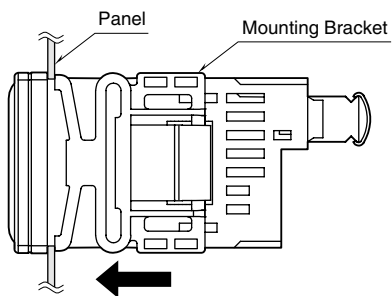

## COMPONENT IDENTIFICATION

### ■ TOP VIEW

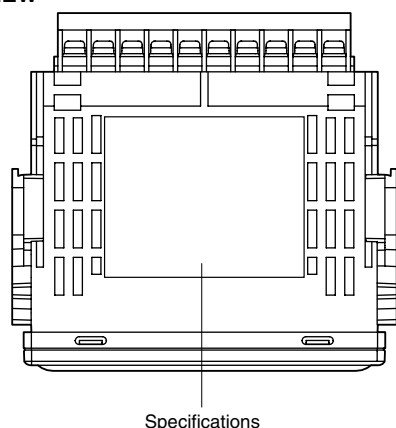

### ■ SIDE VIEW

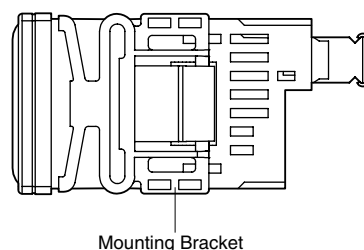

### ■ FRONT VIEW

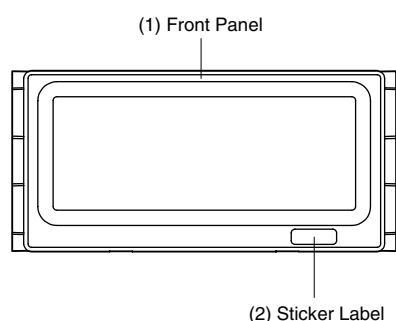

### • Front View without the Front Panel

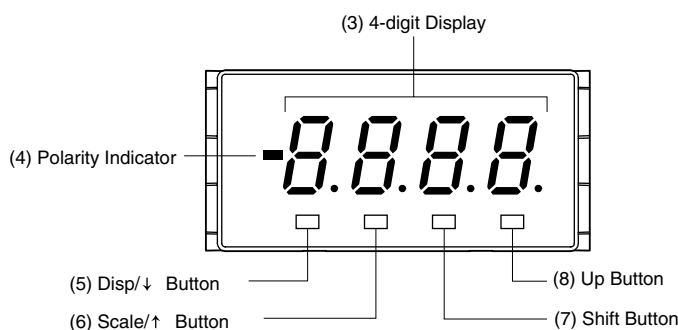

### ■ COMPONENT IDENTIFICATION

No.	COMPONENT	FUNCTION
(1)	Front Panel	Removed at configuration.
(2)	Sticker Label	Engineering unit label position
(3)	4-digit Display	4-digit LED display. Range: 0 to 9999
(4)	Polarity Indicator	Turns on when negative value is displayed
(5)	Disp/↓ Button	Used to move on to the display setting modes; or to shift through setting items in each setting mode.
(6)	Scale/↑ Button	Used to move on to the zero & span adjustment modes; or to shift through setting items in each setting mode.
(7)	Shift Button	Used to move on to the setting standby status and shift through display digits in each setting item.
(8)	Up Button	Used to select setting value.

### ■ HOW TO REMOVE THE FRONT PANEL AT CONFIGURATION

Hold up the front panel and remove it from downside.

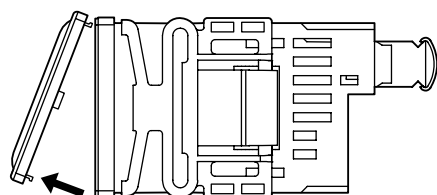

### ■ HOW TO MOUNT THE FRONT PANEL

- 1) Insert the front panel hook into the case upside slots of the unit.
- 2) Push the front panel hook into the case downside slots of the unit.

## TERMINAL CONNECTIONS

Connect the unit as in the diagram below or refer to the connection diagram on the top of the unit.

### EXTERNAL DIMENSIONS unit: mm (inch)

#### TOP VIEW

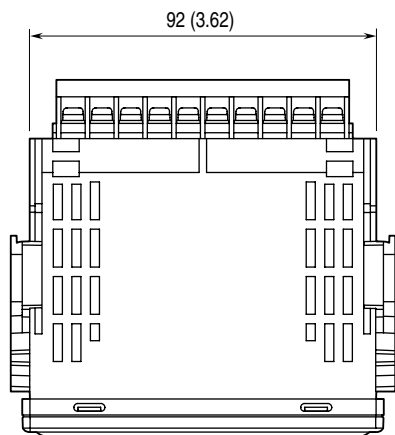

#### FRONT VIEW

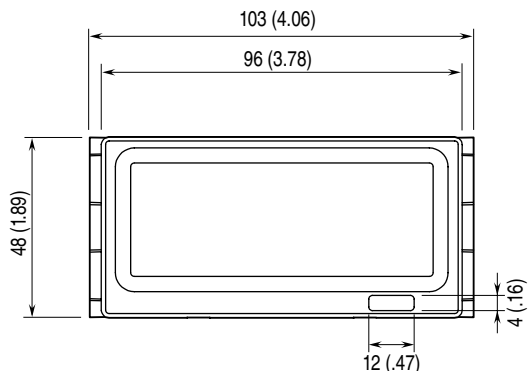

#### SIDE VIEW

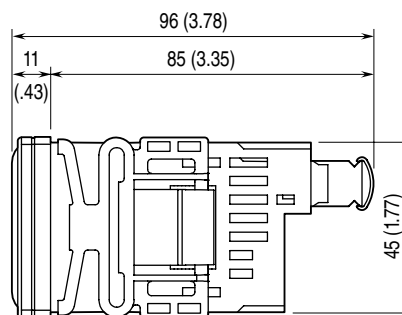

#### REAR VIEW

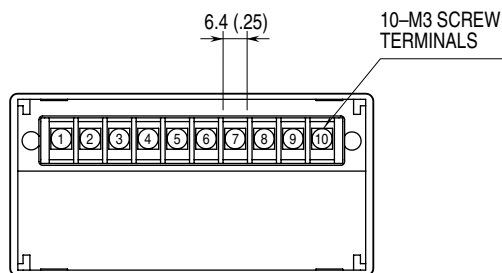

### CONNECTION DIAGRAM

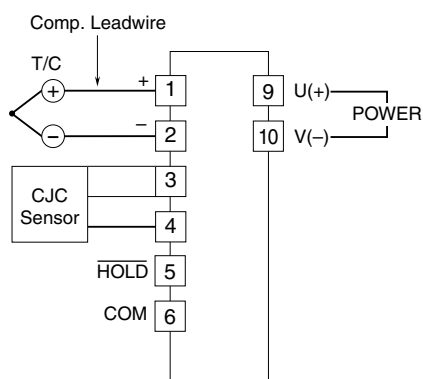

## WIRING INSTRUCTIONS

### SCREW TERMINAL

Torque: 0.6 N·m

### SOLDERLESS TERMINAL

Refer to the drawing below for recommended ring tongue terminal size. Spade tongue type is also applicable.  
Applicable wire size: 0.25 to 1.65 mm<sup>2</sup> (AWG 22 to 16)  
Recommended manufacturer: Japan Solderless Terminal MFG.Co.Ltd, Nichifu Co.,Ltd

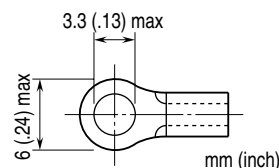

## SETTING PROCEDURE

### ■ INITIAL SETTING FLOWCHART

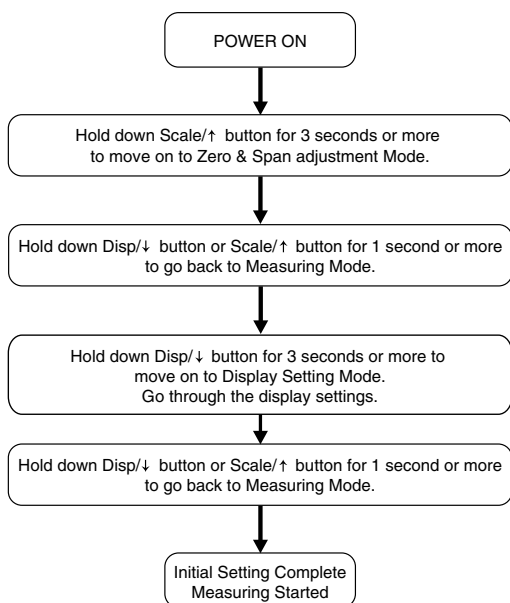

### ■ GENERAL SETTING FLOWCHART

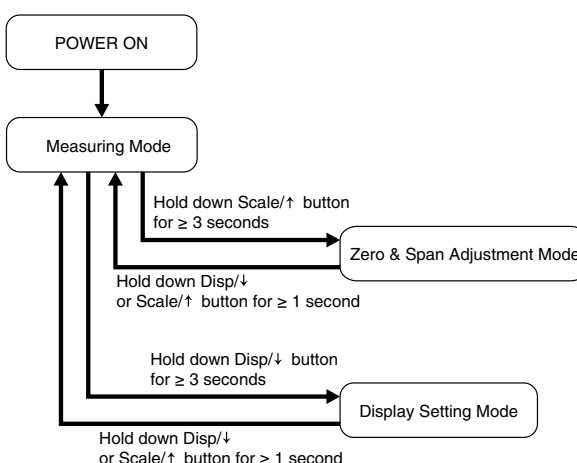

### ■ OPERATIONS IN SETTING MODES

#### • Display

4 digits numeric display including polarity display (referred hereafter as 'display') shows the current settings while the panel meter is in the setting mode.

#### • Shifting through setting parameters

In any setting mode, pressing Disp/↓ button shifts one parameter to the next. Pressing Scale/↑ button shifts one to the previous.

#### • Changing parameters

Pressing Shift button while one of the parameter settings is indicated on the display shifts the panel meter into the setting standby mode. The digit to which you can apply changes starts blinking.

Press Up button to change the blinking value.

Press Shift button to go to the next digit.

Press Disp/↓ or Scale/↑ button to apply the new value and go to the next parameter setting.

If no operation continues more than one minute, while the parameter is blinking, it returns to the parameter before setting. Otherwise it returns to measuring mode.

### ■ EXAMPLE OF SETTING OF MOVING AVERAGE

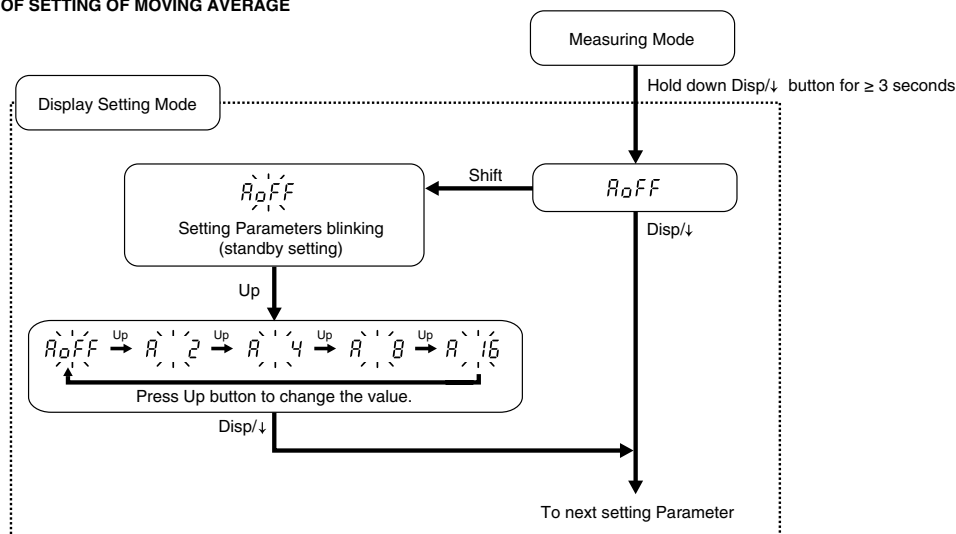

Note: For zero & span adjustment mode the method for using the Shift and Up button is the same as for changing the Setting Parameters.

#### • If you get lost...

Hold down Shift button for 3 seconds or more to return to the measuring mode without applying the last changes. (Those which have been already applied by pressing Disp/↓ or Scale/↑ button are not canceled.)

## ■ ZERO & SPAN ADJUSTMENT MODE

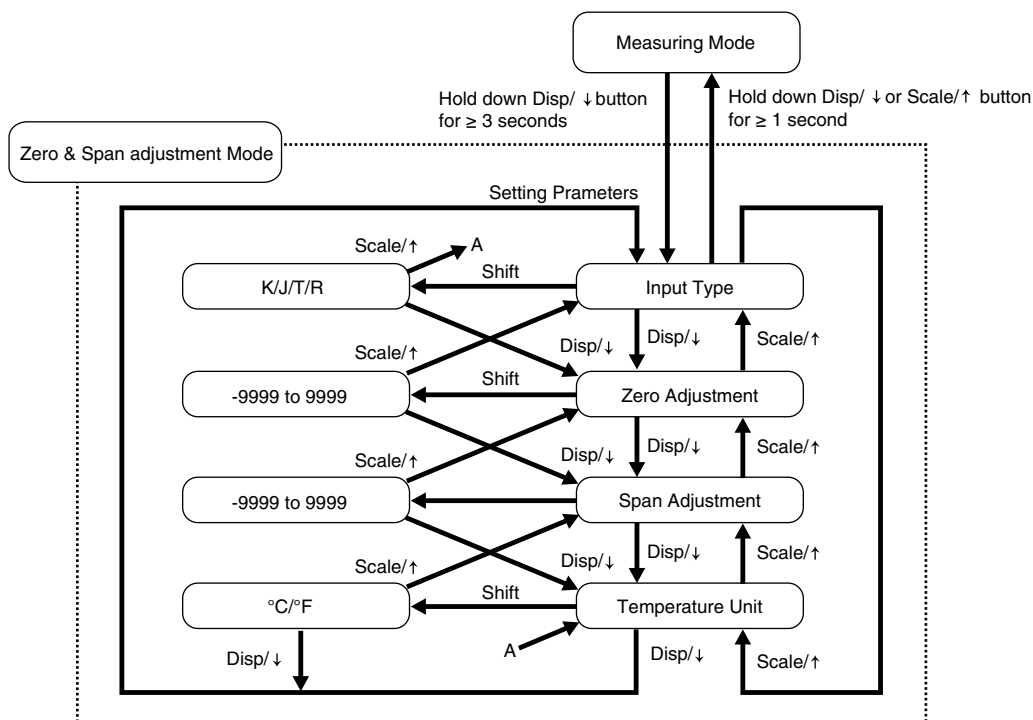

Note: When temperature unit is set to °F, moving to zero/span adjustment is not available.

### • PARAMETER LIST

PARAMETER	DISPLAY	FUNCTION	DEFAULT VALUE
Input type	$\mu$	K thermocouple (usable range -150 to +1370°C, -238 to +2498°F)	$\mu$
	$\downarrow$	J thermocouple (usable range -180 to +1000°C, -292 to +1832°F)	
	$\xi$	T thermocouple (usable range -170 to +400°C, -274 to +752°F)	
	$r$	R thermocouple (usable range 380 to 1760°C, 716 to 3200°F)	
Zero adjustment	$-9999 - 9999$	Adjustment value for 0% of measurement range To distinguish from span adjustment, the first decimal point is blinking	$-0.150$
Span adjustment	$-9999 - 9999$	Adjustment value for 100% of measurement range	$1370$
Temperature unit	$[\text{C}]$	Display in Celsius	$[\text{C}]$
	$[\text{F}]$	Display in Fahrenheit	

### • ZERO/SPAN ADJUSTMENT

When there is an offset in displayed temperature, compensate as the procedure shown below.

- 1) Calculate the value (compensated display value: 0%, 100%) which cancel the difference between max./min. value to set (desired display value: 0%, 100%) and measured value (actual display value: 0%, 100%).
- 2) Calculate the value when the slope of which compensated display value: 0% and 100% are joined with straight line, is elongated to measurement range 0%, 100%.
- 3) Set the value obtained in step (2) as zero/span adjustment.

Refer to the example shown below to calculate the zero/span adjustment.

Example) The display range is set to 0 to 800°C (desired display value) by using K thermocouple, however the display shows -5 to +805°C (actual display value).

#### • Compensated display value calculation

$$Dz = Iz - Cz + Iz$$

$$Ds = Is - Cs + Is$$

$$Dz = 0 - (-5) + 0 = 5$$

$$Ds = 800 - 805 + 800 = 795$$

Iz: Desired display value 0%

Is: Desired display value 100%

Cz: Actual display value 0%

Cs: Actual display value 100%

Dz: Compensated display value 0%

Ds: Compensated display value 100%

#### • Zero/span adjustment setting value calculation

$$Sz = (Rz \times DSPAN + Dz \times Is - Ds \times Iz) \div ISPAN$$

$$Ss = (Rs \times DSPAN + Dz \times Is - Ds \times Iz) \div ISPAN$$

$$Sz = (-150 \times 790 + 5 \times 800 - 795 \times 0) \div 800$$

$$= -114500 \div 800 \approx -143$$

$$Ss = (1370 \times 790 + 5 \times 800 - 795 \times 0) \div 800$$

$$= 1086300 \div 800 \approx 1358$$

Rz: Measurement range 0% (conformance range 0%)

Rs: Measurement range 100% (conformance range 100%)

DSPAN: Compensated display value span (Ds - Dz)

ISPAN: Desired display value span (Is - Iz)

Sz: Zero adjustment

Ss: Span adjustment

By above calculation, zero/span adjustment value setting is as shown below.

Zero adjustment = -0143

Span adjustment = 1358

## ■ DISPLAY SETTING MODE

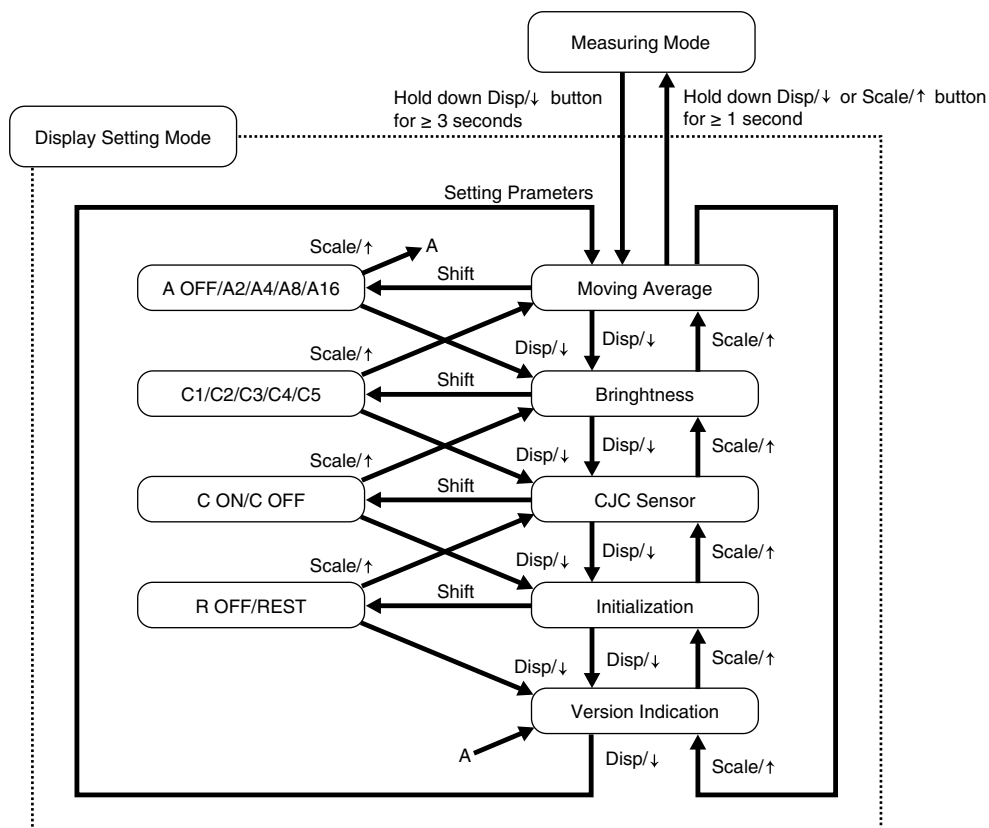

### • PARAMETER LIST

PARAMETER	DISPLAY	FUNCTION	DEFAULT VALUE
Moving Average	OFF	No moving averaging	4
	2	Moving average with 2 samples	
	4	Moving average with 4 samples	
	8	Moving average with 8 samples	
	16	Moving average with 16 samples	
Brightness	1	Brightness level 1 (dark)	5
	2	Brightness level 2	
	3	Brightness level 3	
	4	Brightness level 4	
	5	Brightness level 5 (bright)	
CJC Sensor	on	CJC sensor Enabled	on
	off	CJC sensor Disabled	
Initialization	off	Non-initialization	off
	reset	Initialize settings (change to factory settings) *1	
Version Indication	-	Version number, indication only	-

\*1. While "reset" is shown, pressing Disp/↓ button or Scale/↑ button initializes settings.

Activating "initialization", user's specified parameters will be deleted and overwritten with the factory default values. Notice that after this, Ex-factory settings will be irrecoverable.



## DISPLAY HOLD COMMAND

Displayed value is held with an external HOLD command input. Connect the contacts across  $\overline{\text{HOLD}}$  to COM.

### • WIRING EXAMPLES

(a) 5V-CMOS, TTL

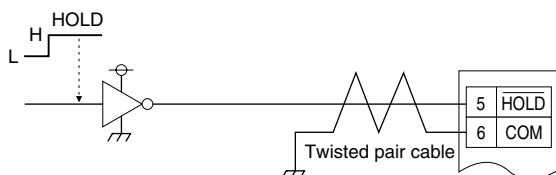

(b) Transistor

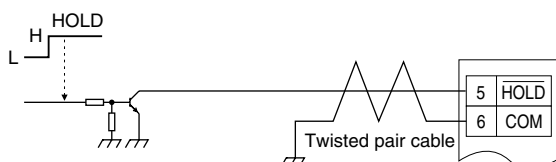

(c) Photo-Coupler

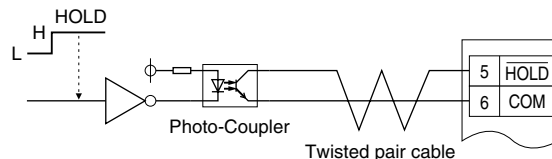

(d) Relay

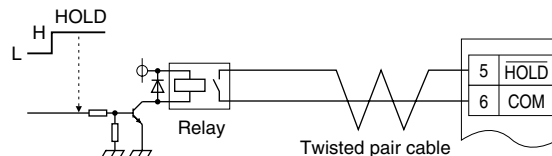

## ERROR MESSAGES

DISPLAY	ERROR MESSAGE	WHAT TO DO
<i>S.E.r.r</i> blinking	The input signal is out of the permissible range.	Set the input signal within the permissible range.
<i>b.E.r.r</i> blinking	The input signal shows breaking of wire.	Check the input signal.

Note: While an external HOLD command is input, the display keeps the value at the HOLD command turning on, even though the input is out of range.

## CHARACTER SET

0	1	2	3	4	5	6	7	8	9	A	B	C	D	E	F	G	H	I	J	K	L	M	N	O	P	Q	R	S	T	U	V	W	X	Y	Z
0	1	2	3	4	5	6	7	8	9	A	b	C	d	E	F	G	H	,	U	P	L	ñ	n	o	P	q	r	S	t	U	u	Y	z	≡	

## LIGHTNING SURGE PROTECTION

We offer a series of lightning surge protectors for protection against induced lightning surges. Please contact us to choose appropriate models.