

Absolute Encoders – Multiturn

**Compact
electronic Multiturn, optical**

Sendix F3663 / F3683 (Shaft / Hollow shaft)

SSI / BiSS-C



The Sendix F36 multiturn with the patented Intelligent Scan Technology™ is an optical multiturn encoder in miniature format, without gears and with 100% insensitivity to magnetic fields. With a size of just 36 x 42 mm it offers a through hollow shaft of up to 8 mm or a blind hollow shaft of up to 10 mm.



Safety-Lock™



High rotational speed



Temperature range
-40°...+90°C



High protection level



High shaft load capacity



Shock / vibration resistant



Magnetic field proof



Reverse polarity protection

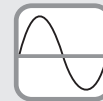

SinCos



Optical sensor



Seawater-resistant version on request

Reliable and insensitive

- Sturdy bearing construction in Safety-Lock™ Design for resistance against vibration and installation errors
- Reduced number of components ensures magnetic insensitivity
- IP67 protection and wide temperature range -40°C ... +90°C
- Patented Intelligent Scan Technology™ (with all singleturn and multiturn functions on one single OptoASIC) - offering highest reliability, a high resolution up to 41 bits and 100% magnetic field insensitivity

Optimised performance

- High precision with data refresh rate of the position value $\leq 1\mu\text{s}$
- High resolution feedback in real-time via incremental outputs SinCos and RS422
- Short control cycles, clock frequency with SSI up to 2 MHz / with BiSS-C up to 10 MHz

Order code Shaft version

8.F3663
Type

.XXXXX.XXX2
a b c d e f g

If for each parameter of an encoder the underlined preferred option is selected, then the delivery time will be 10 working days for a maximum of 10 pieces.

Qts. up to 50 pcs. of these types generally have a delivery time of 15 working days.



a Flange

- 1 = clamping flange, IP67, \varnothing 36 mm [1.42"]
- 3 = clamping flange, IP65, \varnothing 36 mm [1.42"]
- 2 = synchro flange, IP67, \varnothing 36 mm [1.42"]
- 4 = synchro flange, IP65, \varnothing 36 mm [1.42"]

b Shaft ($\varnothing \times L$), with flat

- 1 = \varnothing 6 x 12.5 mm [0.24 x 0.49"]
- 3 = \varnothing 8 x 15 mm [0.32 x 0.59"]
- 5 = \varnothing 10 x 20 mm [0.39 x 0.79"]
- 2 = \varnothing 1/4" x 12.5 mm [0.49"]
- 4 = \varnothing 3/8" x 5/8"

c Interface / Power supply

- 1 = SSI or BiSS-C / 5 V DC
- 2 = SSI or BiSS-C / 10 ... 30 V DC
- 3 = SSI or BiSS-C + 2048 ppr SinCos / 5 V DC
- 4 = SSI or BiSS-C + 2048 ppr SinCos / 10 ... 30 V DC
- 5 = SSI or BiSS-C, with sensor output for monitoring the voltage on the encoder / 5 V DC
- 6 = SSI or BiSS-C + 2048 ppr SinCos, with sensor output for monitoring the voltage on the encoder / 5 V DC
- 7 = SSI or BiSS-C + 2048 ppr incr. signals RS422 / 5 V DC
- 8 = SSI or BiSS-C + 2048 ppr incr. signals RS422 / 10 ... 30 V DC

d Type of connection

- 1 = cable, tangential, 1 m [3.28'] PUR
- 3 = cable tangential, 5 m [16.40'] PUR
- 5 = cable, tangential, 1 m [3.28'] PUR with M12 connector for central fastening, 8-pin ¹⁾

e Code

- B = SSI, Binary
 - C = BiSS-C, Binary
 - G = SSI, Gray
- optional on request
- Ex 2/22
- seawater-resistant
- special cable length

f Resolution (Singleturn)

- A = 10 bit ST
- 2 = 12 bit ST
- 3 = 13 bit ST
- 4 = 14 bit ST
- 7 = 17 bit ST

g Resolution (Multiturn)

- 2 = 12 bit MT
- 6 = 16 bit MT
- 4 = 24 bit MT

1) Only with interface 1 and 2

Absolute Encoders – Multiturn

Compact electronic Multiturn, optical	Sendix F3663 / F3683 (Shaft / Hollow shaft)	SSI / BiSS-C
--	--	---------------------

Order code	8.F3683	.XXXX.XXX2	If for each parameter of an encoder the <u>underlined preferred option</u> is selected, then the delivery time will be 10 working days for a maximum of 10 pieces. Qts. up to 50 pcs. of these types generally have a delivery time of 15 working days.								
Hollow shaft	Type	<table border="1" style="font-size: x-small;"> <tr> <td style="text-align: center;">a</td><td style="text-align: center;">b</td><td style="text-align: center;">c</td><td style="text-align: center;">d</td><td style="text-align: center;">e</td><td style="text-align: center;">f</td><td style="text-align: center;">g</td> </tr> </table>	a	b	c	d	e	f	g		
a	b	c	d	e	f	g					
a Flange	1 = with spring element short, IP65 3 = with spring element long, IP65 <u>2 = with stator coupling, ø 46 mm [1.81"]</u>	c Interface / Power supply	1 = SSI or BiSS-C / 5 V DC <u>2 = SSI or BiSS-C / 10 ... 30 V DC</u> 3 = SSI or BiSS-C + 2048 ppr SinCos / 5 V DC 4 = SSI or BiSS-C + 2048 ppr SinCos / 10 ... 30 V DC 5 = SSI or BiSS-C, with sensor output for monitoring the voltage on the encoder / 5 V DC 6 = SSI or BiSS-C + 2048 ppr SinCos, with sensor output for monitoring the voltage on the encoder / 5 V DC 7 = SSI or BiSS-C + 2048 ppr incr. signals RS422 / 5 V DC 8 = SSI or BiSS-C + 2048 ppr incr. signals RS422 / 10 ... 30 V DC	e Code	optional on request - Ex 2/22 - seawater-resistant - special cable length						
b Hollow shaft	1 = ø 6 mm [0.24"] 3 = ø 8 mm [0.32"] <u>4 = ø 10 mm [0.39"], blind hollow shaft</u> 2 = ø 1/4"	d Type of connection	<u>1 = cable, tangential, 1 m [3.28'] PUR</u> 3 = cable tangential, 5 m [16.40'] PUR 5 = cable, tangential, 1 m [3.28'] PUR with M12 connector for central fastening, 8-pin ¹⁾	f Resolution (Singleturn)	A = 10 bit ST 2 = 12 bit ST <u>3 = 13 bit ST</u> 4 = 14 bit ST 7 = 17 bit ST						
				g Resolution (Multiturn)	<u>2 = 12 bit MT</u> 6 = 16 bit MT 4 = 24 bit MT						

Mounting accessory for shaft encoders	Order No.
Coupling Bellows coupling ø 19 mm [0.75"] for shaft 8 mm [0.32"]	8.0000.1101.0808

Mounting accessory for hollow shaft encoders	Order No.
Cylindrical pin, long for torque stops <div style="display: flex; align-items: center; margin-top: 10px;"> <div style="margin-left: 10px;">With fixing thread</div> </div>	8.0010.4700.0000

Connection technology	Order No.
Connector, self-assembly (straight) M12 female connector with coupling nut	05.CMB 8181-0
Cordset, pre-assembled M12 female connector with coupling nut, 2 m [6.56'] PUR cable	05.00.6051.8211.002M

Further accessories can be found in the accessories section or in the accessories area of our website at: www.kuebler.com/accessories
 Additional connectors can be found in the connection technology section or in the connection technology area of our website at: www.kuebler.com/connection_technology

Technical data

Mechanical characteristics	
Maximum speed	
Shaft- or blind hollow shaft version without shaft seal (IP65)	12 000 min ⁻¹ 10 000 min ⁻¹ (continuous)
Shaft version (IP67) or hollow shaft version (IP65) with shaft seal	10 000 min ⁻¹ 8 000 min ⁻¹ (continuous)
Starting torque at 20°C [68°F]	without shaft seal < 0.007 Nm with shaft seal (IP67) < 0.01 Nm
Shaft load capacity	radial 40 N axial 20 N
Weight	approx. 0.2 kg [7.06 oz]

Protection acc. to EN 60529	housing side IP67 shaft side IP65 (solid shaft version opt. IP67)
EX approval for hazardous areas	optional Zone 2 and 22
Working temperature range	-40°C ... +90°C [-40°F ... +194°F]
Materials	shaft / hollow shaft stainless steel flange aluminium housing zinc die-cast cable PUR
Shock resistance acc. to EN 60068-2-27	2500 m/s ² , 6 ms
Vibration resistance acc. to EN 60068-2-6	100 m/s ² , 55 ... 2000 Hz

1) Only with output circuits 1 and 2

Absolute Encoders – Multiturn

Compact electronic Multiturn, optical	Sendix F3663 / F3683 (Shaft / Hollow shaft)	SSI / BiSS-C
--	--	---------------------

Electrical characteristics	
Power supply	5 V DC \pm 5% or 10 ... 30 V DC
Current consumption (no load)	5 V DC max. 60 mA 10 ... 30 V DC max. 30 mA
Reverse polarity protection of the power supply	yes (only with 10 ...30 V DC)
Short-circuit proof outputs	yes ¹⁾
UL approval	File 224618
CE compliant acc. to	EMC guideline 2004/108/EC
RoHS compliant acc. to	guideline 2011/65/EU

SSI interface	
Output driver	RS485 transceiver type
Permissible load/channel	max. \pm 30 mA
Signal level	HIGH typ 3.8 V LOW with $I_{Load} = 20$ mA typ 1.3 V
Resolution singleturn	10 ... 17 bit
Number of revolutions	max. 24 bit
Code	Binary or Gray
SSI clock rate	ST resolution \leq 14 bit 50 kHz ... 2 MHz ST resolution \geq 15 bit 50 kHz ... 125 kHz
Monoflop time	\leq 15 μ s
Note:	If the clock cycle starts within the monoflop time a second data transfer begins with the same data. If the clock cycle starts after the monoflop time the cycle begins with the new values. The update rate is dependent on the clock speed, data length and monoflop time.
Data refresh rate	ST resolution \leq 14 bit \leq 1 μ s ST resolution \geq 15 bit 4 μ s
Status and Parity bit	on request

BiSS-C interface	
Resolution, singleturn	10 ... 17 bit
Number of revolutions	max. 24 bit
Code	Binary
BiSS-C Clock rate	up to 10 MHz
Max. update rate	$<$ 10 μ s, depends on the clock rate and the data length
Data refresh rate	\leq 1 μ s
Note::	<ul style="list-style-type: none"> – Bidirectional, factory programmable parameters are: resolution, code, direction, alarms and warnings – CRC data verification

Incremental outputs (A/B), 2048 ppr		
	SinCos	RS422 TTL-compatible
Max. frequency -3dB	400 kHz	400 kHz
Signal level	1 V _{pp} (\pm 20%)	HIGH: min. 2.5 V LOW: max. 0.5 V
Short circuit proof	yes ¹⁾	yes ¹⁾

SET input	
Input	active HIGH
Input type	comparator
Signal level	HIGH min. 60 % of +V, max: +V LOW max. 30 % of +V
Input current	$<$ 0.5 mA
Min. pulse duration (SET)	10 ms
Input delay	1 ms
New position data readable after	1 ms
Internal processing time	200 ms

The encoder can be set to zero at any position by means of a HIGH signal on the SET input. Other preset values can be factory-programmed. The SET input has a signal processing time of approx. 1 ms, after which the new position data can be read via SSI or BiSS-C. Once the SET function has been triggered, the encoder requires an internal processing time of typ. 200 ms; during this time the power supply must not be switched off. The SET function should be carried out whilst the encoder is at rest.

Power ON delay	
After Power-ON the device requires a time of approx. 150 ms before valid data can be read. Hot plugging of the encoder should be avoided.	

DIR input	
A HIGH signal switches the direction of rotation from the default CW to CCW. This inverted function can also be factory-programmed. If DIR is changed when the device is already switched on, then this will be interpreted as an error. The status output will switch to LOW.	
Response time (DIR input)	1 ms

Status output	
Output driver	Open Collector, internal pull up resistor 22 kOhm
Permissible load	max. 20 mA
Signal level	HIGH +V LOW $<$ 1 V
Active	LOW
The status output serves to display various alarm or error messages. In normal operation the status output is HIGH (Open Collector with int. pull-up 22 kOhm).	
An active status output (LOW) displays: LED fault (failure or ageing) – over-temperature – undervoltage In the SSI mode, the fault indication can only be reset by switching off the power supply to the device.	

¹⁾ Short circuit proof to 0 V or to output when power supply correctly applied

Absolute Encoders – Multiturn

**Compact
electronic Multiturn, optical**

Sendix F3663 / F3683 (Shaft / Hollow shaft)

SSI / BiSS-C

Terminal assignment

Interface	Type of connection	Features	Cable (Isolate unused wires individually before initial start-up)
1, 2	1, 3	SET, DIR, Status	Signal: 0 V +V C+ C- D+ D- SET DIR Stat \perp
			Cable colour: WH BN GN YE GY PK BU RD VT Shield
1, 2	5	SET, DIR	M12 connector
			Signal: 0 V +V C+ C- D+ D- SET DIR \perp
1, 2	5	SET, DIR	Pin: 1 2 3 4 5 6 7 8 PH
3, 4	1, 3	SET, DIR, 2048 SinCos	Cable (Isolate unused wires individually before initial start-up)
			Signal: 0 V +V C+ C- D+ D- SET DIR A \bar{A} B \bar{B} \perp
3, 4	1, 3	SET, DIR, 2048 SinCos	Cable colour: WH BN GN YE GY PK BU RD BK VT GY-PK RD-BU Shield
5	1, 3	SET, DIR, Sensor outputs	Cable (Isolate unused wires individually before initial start-up)
			Signal: 0 V +V C+ C- D+ D- SET DIR 0 Vsens +Vsens \perp
5	1, 3	SET, DIR, Sensor outputs	Cable colour: WH BN GN YE GY PK BU RD VT RD-BU Shield
6	1, 3	2048 SinCos, Sensor outputs	Cable (Isolate unused wires individually before initial start-up)
			Signal: 0 V +V C+ C- D+ D- 0 Vsens +Vsens A \bar{A} B \bar{B} \perp
6	1, 3	2048 SinCos, Sensor outputs	Cable colour: WH BN GN YE GY PK BU RD BK VT GY-PK RD-BU Shield
7, 8	1, 3	2048 incr. RS422	Cable (Isolate unused wires individually before initial start-up)
			Signal: 0 V +V C+ C- D+ D- A \bar{A} B \bar{B} \perp
7, 8	1, 3	2048 incr. RS422	Cable colour: WH BN GN YE GY PK BK VT GY-PK RD-BU Shield

- +V: Encoder power supply +V DC
- 0 V: Encoder power supply ground GND (0 V)
- 0 Vsens / +Vsens: Using the sensor outputs of the encoder, the voltage present can be measured and if necessary increased accordingly.
- A, \bar{A} : Incremental output channel A
- B, \bar{B} : Incremental output channel B
- C+, C-: Clock signal
- D+, D-: Data signal
- SET: Set input. The current position becomes defined as position zero.
- DIR: Direction input: If this input is active, output values are counted backwards (decrease) when the shaft is turning clockwise.
- Stat: Status output
- PH \perp : Plug connector housing (Shield)

Top view of mating side, male contact base



M12 connector, 8-pin

Absolute Encoders – Multiturn

**Compact
electronic Multiturn, optical**

Sendix F3663 / F3683 (Shaft / Hollow shaft)

SSI / BiSS-C

Dimensions shaft version

Dimensions in mm [inch]

**Clamping flange, \varnothing 36 [1.42]
Flange type 1 and 3**

- 1 M3, 6 [0.24] deep
- 2 Battery (in the cable)

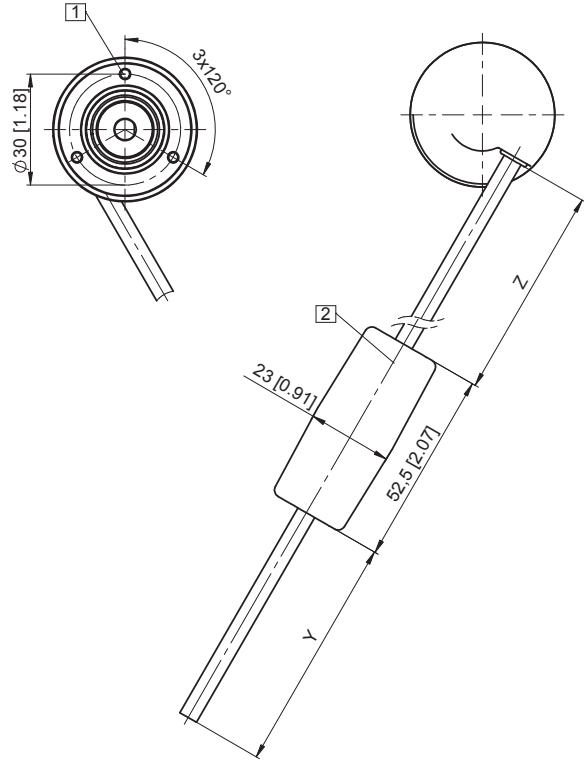
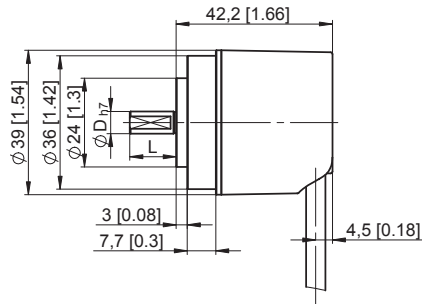

D	L	Fit
6 [0.24]	12.5 [0.49]	h7
8 [0.32]	15 [0.59]	h7
10 [0.39]	20 [0.79]	h7
1/4"	12.5 [0.49]	h7
3/8"	5/8"	h7

Y	Z
1 m [3.28']	0.15 m [0.49']
5 m [16.40']	0.15 m [0.49']

Synchro flange, \varnothing 36 [1.42]

**Flange type 2 and 4
(Drawing with cable)**

- 1 M3, 6 [0.24] deep
- 2 Battery (in the cable)

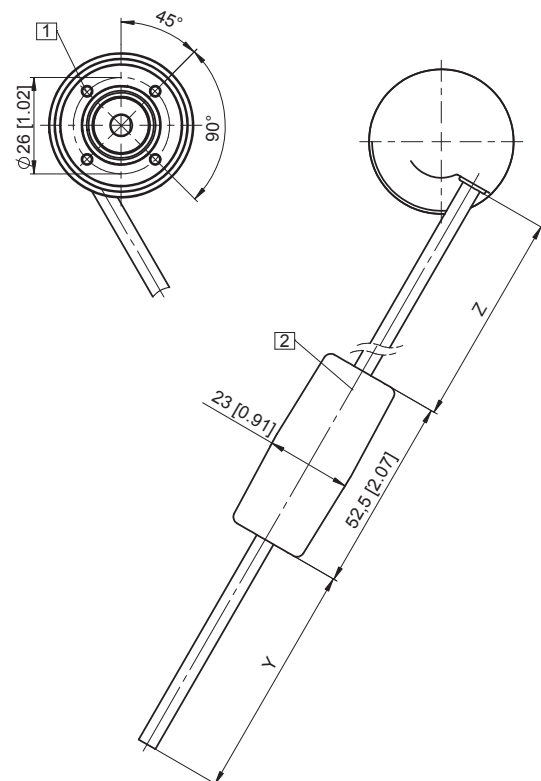
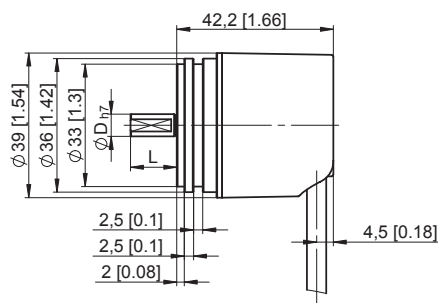

D	L	Fit
6 [0.24]	12.5 [0.49]	h7
8 [0.32]	15 [0.59]	h7
10 [0.39]	20 [0.79]	h7
1/4"	12.5 [0.49]	h7
3/8"	5/8"	h7

Y	Z
1 m [3.28']	0.15 m [0.49']
5 m [16.40']	0.15 m [0.49']

Absolute Encoders – Multiturn

**Compact
electronic Multiturn, optical**

Sendix F3663 / F3683 (Shaft / Hollow shaft)

SSI / BiSS-C

Dimensions hollow shaft version

Dimensions in mm [inch]

Flange with spring element

Flange type 1 and 3

(Drawing with spring element short, spring element long is shown dashed)

- 1 M2.5, 5 [0.20] deep
- 2 Spring element short
Recommendation:
Cylindrical pin DIN 7, \varnothing 4 [0.16]
- 3 Spring element long
Recommendation:
Cylindrical pin DIN 7, \varnothing 4 [0.16]
- 4 Battery (in the cable)
- 5 Recommended torque for the clamping ring 0.6 Nm

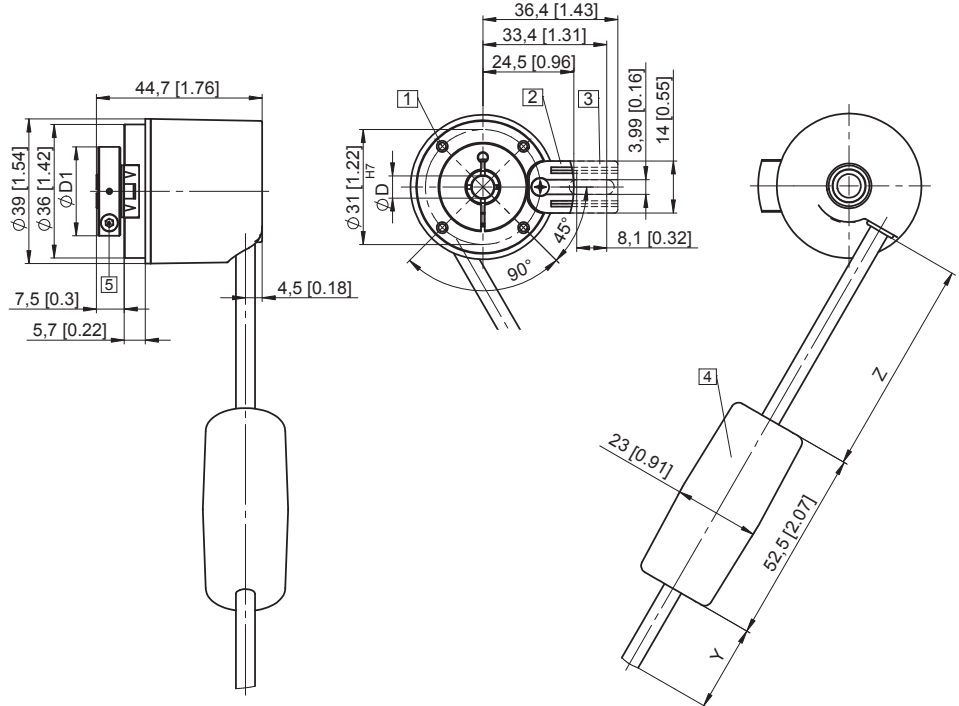

D	D1
6 [0.24]	24 [0.94]
8 [0.32]	25.5 [1.00]
10 [0.39]	25.5 [1.00]
1/4"	24 [0.94]

Y	Z
1 m [3.28']	0.15 m [0.49']
5 m [16.40']	0.15 m [0.49']

Insertion depth for blind hollow shaft 14.5 [0.57]

Flange with stator coupling, \varnothing 46 [1.81]

Flange type 2

- 1 Battery (in the cable)
- 2 Recommended torque for the clamping ring 0.6 Nm

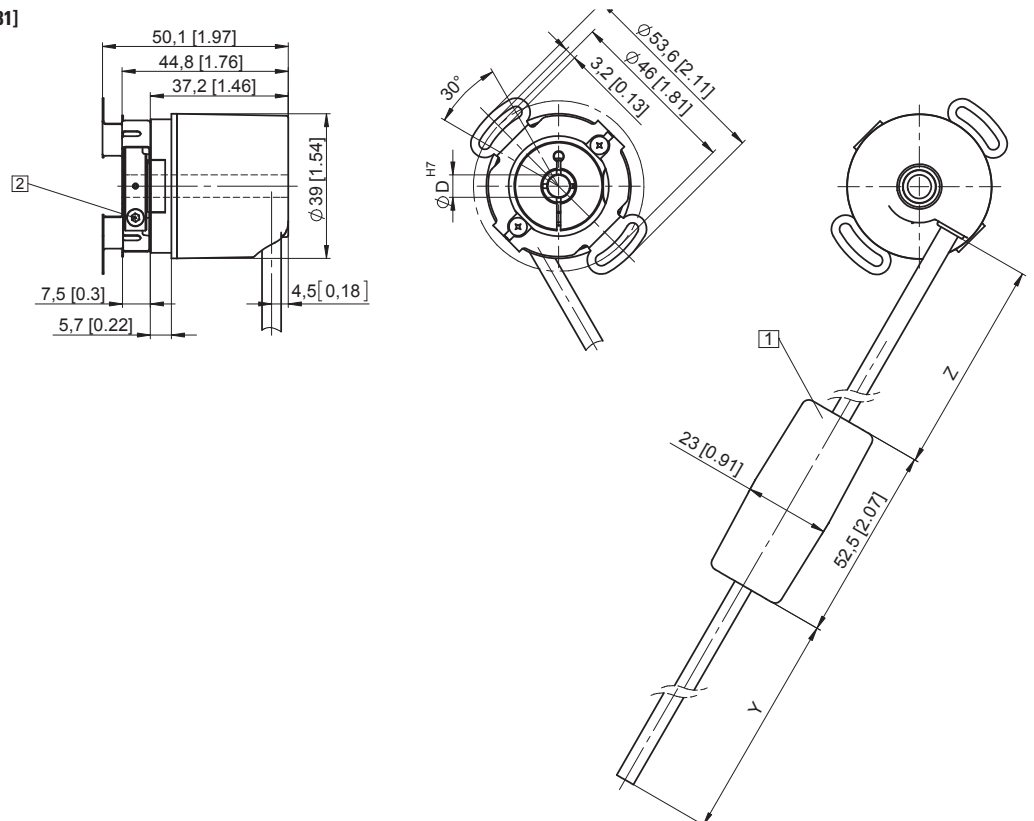

D	D1
6 [0.24]	24 [0.94]
8 [0.32]	25.5 [1.00]
10 [0.39]	25.5 [1.00]
1/4"	24 [0.94]

Y	Z
1 m [3.28']	0.15 m [0.49']
5 m [16.40']	0.15 m [0.49']

Insertion depth for blind hollow shaft 14.5 [0.57]